



**U.S. Department of Energy - Energy Efficiency and Renewable Energy
Energy Matters**

**Performance Optimization Tips: Liberal Application of a
Conservative Principle**

From the [March/April 2001](#) issue of Energy Matters

By Don Casada, OIT BestPractices Program

A little puzzle: Can you give me some feedback about what Newton's third law of motion has in common with the following items?

1. The economic model of supply and demand
2. Loudspeaker squealing
3. The Chernobyl nuclear reactor
4. The California electricity crisis
5. Wasted energy in industrial plant operations

Here's a clue: The answer is in the question. Let's discuss each item and look for a common thread.

Newton's third law of motion says that: For every action, there is an equal and opposite reaction. If I push (or pull) on an inanimate object, it pushes (or pulls) back with a reactionary, or balancing force, exactly equal to the one applied.

1. *The economic model of supply and demand* deals with the interrelationship between supply, demand, and price. In a stable market of widgets, supply and demand are matched. Then something happens to create a shortage of widgets, and competition for the scarce resource grows.

We would expect prices to increase enough to cause an initial reduction in demand. But the new, higher price may also attract more suppliers, and prices may reverse. The cycling iterates, but always seeks a balance between the competing forces.

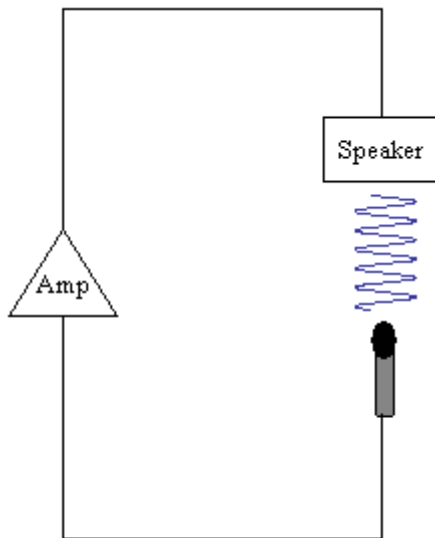

Speaker and Microphone Loop.

2. *Loudspeaker squealing* occurs because of problems in location of a microphone and the loudspeaker. The figure below shows a situation where a microphone is positioned directly under a speaker. A small sound into the microphone will be amplified and sent through the speaker. The higher volume sound will repeat the cycle. The distance between the speaker and the microphone will affect the frequency, but the existence of the closed, self-amplifying loop is the primary cause of the squealing.

3. *The Chernobyl nuclear reactor catastrophe* was largely the result of a fundamental design flaw. Its reactor core was designed to have a positive power reactivity coefficient¹. That is, as the nuclear power in the core increased, it tended to cause a further increase. So, once an excursion started, it was self-propagating.

4. *The California electricity crisis* is a result of several cause and result factors, including:

- A significantly increased demand coincident with minimal new capacity
- Retail price controls for two major utilities (fixed selling prices well below the utility purchase costs)
- Utilities were prohibited from entering into long-term contracts
- Heavy dependence on natural gas generation (and at a time of soaring natural gas prices)
- Independent power producers who weren't being paid.

Feedback on the Puzzle

Before we discuss the fifth item, I'll give you my answer to the puzzle. All the items on the list, like Newton's third law of motion, either have or should have a properly controlling feedback system.

Essentially all real-world processes require feedback-type control. We continuously rely on feedback from our native senses to control almost everything we do, from brushing our teeth to driving a car.



Negative feedback is implicit in Newton's third law. Forces in nature always seek balance. Likewise, the economic model of supply and demand, which is also based on empirical observation, includes combinations of negative feedback mechanisms that tend to restore balance.

Both the loudspeaker and the Chernobyl reactor are examples of positive feedback designs, where an imbalance reinforces itself out of control. Any time a positive feedback dominates, bad things tend to happen because balance is fundamentally lost. It's interesting that in the physical world, negative feedback is a positive thing, and positive feedback is a negative thing.

As to the California electricity crisis, you are certainly free to draw your own conclusions. But to a remote, casual observer like me, it appears that artificial constraints imposed on time-proven, market-negative feedback mechanisms, such as prices, demand, and supply, are prime factors.

Which leaves us with one last item on our original list:

5. Wasted energy in industrial plant operations, in my experience, involve factors that, somewhat like the California situation, either:

- Inhibit the natural, negative feedback control mechanisms that seek balance, or
- Misdirect the feedback to the result, rather than the source, of the imbalance between supply and demand.

Inhibited feedback

If one end user in the plant gets an insufficient supply of plant utilities, such as compressed air, steam, and water—even if only for 10 minutes a month—the utility staff will certainly hear about it. And that's fine—it is negative feedback from the user to the supplier. But if there is more pressure or flow rate, the user will take care of that by bypassing or throttling the supply. A direct result is the utility staff operates more equipment than needed for normal operating conditions. But the higher costs that result from meeting the single end user's infrequent need aren't borne solely by that end user, because utility bills are an overall plant burden. Thus, there is inherent minimization of negative feedback from the supplier to the user, resulting in a loss of balance.

However, balance can be encouraged by other mechanisms. First, there is submetering. The closer the energy/cost meter is to the end user, the more likely it is he or she will be held accountable. Second, a review of the plant's entire consumption pattern can identify the "bad actors" in the facility. Both of these approaches help compensate for the missing "equal and opposite force" and can result in more efficient use of resources.

Misdirected feedback

Controlling flow rate by a throttled valve or damper is an example where feedback addresses a supply and demand imbalance at the end of the process. Controlling flow rate with a valve or damper is analogous to:

- Driving a car with the gas pedal "to the metal" and then regulating speed with the brake, or
- Putting on sunglasses in a room where the lights are too bright.



PeerlessPump.com / LabourTaber.com

Using a variable speed drive or on/off operation to control flow rate are examples where the imbalance is addressed at the source. They are analogous to our more common methods of controlling speed (gas pedal) and lights (dimmers or switches).

Operating reviews and plant assessments can help identify misdirected feedback. OIT's BestPractices offers prescreening and opportunity scoping tools for different system types, such as pumping and steam. You can find these tools on the [BestPractices Web site](#).

Feedback Worthy of Emulation

The few natural laws that we have been fortunate enough to decode from empirical observations, like Newton's third law of motion, are cornerstones for our technological energy world. But they have much to teach us in a more liberal sense.

The evidence consistently shows that the designer of the universe has consistently incorporated negative feedback control into its physical and biological operations. And one can't help but to be amazed at how smoothly and efficiently it works. We human designers and operators might be well served to consider the importance of appropriately applying negative feedback if we're interested in working more smoothly and efficiently in our own, more limited scopes of responsibility.

E-mail Don Casada at: doncasada@icx.net.

1 All U.S. reactors are required to have a negative power reactivity coefficient, which means their power is self-limiting.