

Close coupled condensate pump and receiver

P Series

Instructions

- Installation
- Operation
- Maintenance

Read this entire book before attempting to install, operate or repair this pump. Properly installed, your Peerless pump will give you satisfactory, dependable service. We urge that you read carefully these step-by-step instructions, to simplify any problems of installation, operation or repair.

Failure to read and comply with installation and operating instructions will void the responsibility of the

manufacturer and may also result in bodily injury as well as property damage.

This book is intended to be a permanent part of your pump installation and should be preserved in a convenient location for ready reference. If these instructions should become soiled, obtain a new copy from Peerless Pump. Include pump model and/or serial number with your request.



Peerless Pump Company
2005 Dr. Martin Luther King Jr. Street
Indianapolis, IN 46202
Phone: (317) 925-9661 • Fax: (317) 924-7388

Sterling Fluid Systems (USA), Inc.

Bulletin
4852885
Rev. 12/91

WARRANTY

New equipment manufactured by Seller is warranted to be free from defects in material and workmanship under normal use and service for a period of one year from date of shipment; Seller's obligation under this warranty being limited to repairing or replacing at its option any part found to its satisfaction to be so defective provided that such part is, upon request, returned to Seller's factory from which it was shipped, transportation prepaid. This warranty does not cover parts damaged by decomposition from chemical action or wear caused by abrasive materials, nor does it cover damage resulting from misuse, accident, neglect, or from improper operation, maintenance, installation, modification or adjustment. This warranty does not cover parts repaired outside Seller's factory without prior written approval. Seller makes no warranty as to starting equipment, electrical apparatus or other material not of its manufacture, since the same are usually covered by warranties of the respective manufacturers thereof.

In the event, notwithstanding the terms of this agreement, it is determined by a court of competent jurisdiction that an express warranty has been given by Seller to Purchaser with respect to the head, capacity or other like performance characteristics of said equipment, Seller's liability for breach of the same shall be limited to accepting return of such equipment F.O.B. plant of manufacture, refunding any amount paid thereon by Purchaser (less depreciation at the rate of 15% per year if Purchaser has used equipment for more than thirty (30) days) and cancelling any balance still owing on the equipment.

This warranty is expressly in lieu of any other warranties, expressed or implied, and Seller specifically disclaims any implied warranty of merchantability or fitness for a particular purpose.

IMPORTANT SAFETY PRECAUTIONS

Pump parts and the tools and lifting equipment used in installation are heavy and may easily cause personal injury, if dropped or carelessly handled. The normal precautions and safety rules associated with the installation or repair of machinery, in regard to manual lifting, use of power equipment, and handling of tools, must be observed in the installation of this pump.

Petroleum-base cleaning solvents are flammable. Smoking by personnel, open flame, or other activity which could ignite vapors in the vicinity of these solvents is extremely hazardous and must not be permitted.

Do not work under a suspended object unless there is a positive support under it to stop its fall in event of sling or hoist failure.

Before attempting examination, handling or repair, be certain that the electrical current to the motor is shut off. An electrical shock from contact with live wires or cords can be fatal.

Before attempting examination or repairs to pump, open the disconnect switch to electric motor. This prevents accidental running of pump motor. Starting motor during examination or repair activities could damage pump and may cause personal injury.

A replacement electric motor must be of the same voltage, RPM and frame number as original motor. If replacement motor is of higher RPM, pump will develop excessive pressure and horsepower, causing pump and equipment damage and personal injury.

WARNING

The pumps described in this bulletin must not be installed in any manner except as specified herein, and must not be operated with different electrical power supplied than listed on the motor nameplate. Pumps are designed to operate in gravity feed condensate return steam heating systems or in medium to low pressure condensate return steam heating systems at 10 inches of mercury vacuum to 30 psig, and at temperature not more than 180°F (82°C).

The receiver must be properly vented to avoid exposing the receiver to any pressure other than standard atmospheric pressure.

Violation of this warning will void the warranty and may result in serious property damage or grave personal injury.

INSTALLATION

WARNING

Do not work under a suspended object unless there is a positive support under it to stop its fall in event of sling or hoist failure. Disregard of this warning could result in grave personal injury.

CAUTION

Be sure the voltage and frequency indicated on motor nameplate are the same as service provided. If the motor has been wired at the factory, note the voltage caution card. If available service is other than that indicated, consult motor and switch manufacturer's instructions accompanying unit for proper wiring changes.

OPERATION

WARNING

Never operate pump unless discharge is flooded. Failure to do so will injure rotary seal and cause pump to leak.

CAUTION

New or repaired heating systems should be operated several days with the returns open to sewer until water appears clear in order to thoroughly flush and clean the lines and prevent clogging of the pump when it is put into operation. This may take from four days to two weeks.

MAINTENANCE

WARNING

Before attempting examination or repairs to pump, open the disconnect switch to electric motor, to prevent accidental running of pump motor. Starting motor during examination or repair activities could damage pump and may cause personal injury. An electrical shock from contact with live wires or cords can be fatal.

Always take adequate precaution to prevent accidental running of pump motor before starting to remove pump from base. Starting motor during pump removal could damage pump and may cause personal injury.

Before opening conduit box of electric motor, be certain that the current to the motor is shut off. An electrical shock from contact with live motor leads can be fatal.

Let the unit cool to ambient temperature before servicing, as severe burns can result from contact.

Petroleum-base cleaning solvents are flammable. Smoking or open flame in the vicinity of these solvents is extremely hazardous and must not be permitted. Disregard of this warning could result in grave personal injury.

A replacement electric motor must be of the same voltage, RPM and frame number as original motor. If replacement motor is of higher RPM, pump will develop excessive pressure and horsepower, causing pump and equipment damage and personal injury.

CAUTION

Never run pump when receiver is empty, or expose unit to freezing temperature when filled with water, or severe equipment damage can occur.

Use care not to damage highly finished faces of mechanical seal. Any damage to one or both faces will require replacement of entire mechanical seal.

Never use hydrocarbon liquids (oil or solvent) to clean mechanical seal parts. Use of oil or solvent will deteriorate material used for manufacture of the seal.

Clean seal parts using a mild soap solution. Rub only with finger to remove dirt. Rinse with clear water and dry with mild air stream. Use care not to damage or scratch lapped surfaces.

Use care not to mar or scratch the lapped surfaces of floating seat and sealing washer when installing mechanical seal. Damage to these surfaces will result in leakage and will require replacement of the entire seal.

KEEP THESE INSTRUCTIONS NEAR THE PUMP FOR USE OF OPERATOR

INSTALLATION INSTRUCTIONS

Locating Pump: Install unit in a clean, dry, well-ventilated and drained location for inspection and care. The top of the pump receiver should be below the lowest return since it is best to keep the return lines dry. This unit must be placed so the condensate flows into the receiver by gravity, otherwise returns will be wet and the system will not free itself of air.

Piping: Connect returns to inlet of receiver with a gate valve in each return and with a union or flange joint next to the receiver. Provide a drain to sewer from each return. Connect discharge of pump to boiler with a union, swing check valve and a gate valve; with the swing check valve as close to the pump as is possible. If discharge pipe is longer than 50 feet, increase piping to next size larger. Piping must be of correct length to prevent any pipe strain upon the unit.

Wiring: The electrical connections between the motor, float switch and automatic starter (if furnished) are made at the factory. Connect the electric service to the float switch or automatic starter using conduit and wire sizes as required by local power companies. Provide a fused main line switch in motor circuit. **CAUTION:** The motor is wired and connected at the factory to operate on the voltage specified. If voltage is other than originally specified, consult motor manufacturer's instructions accompanying unit for proper wiring. Where a polyphase motor is furnished with only a float switch, **IT WILL BE NECESSARY TO INSTALL A SUITABLE PHASE PROTECTOR SWITCH IN THE MOTOR CIRCUIT TO PREVENT MOTOR BURNOUTS SHOULD A SINGLE PHASE CONDITION OCCUR.**

Fuses: Be sure fuses are installed and comply in size with National Electrical Code recommendations. When a fuse blows out it indicates that something is wrong either in the motor, pump, switch, fuse rating or electric service. Do not replace fuse until the cause for its blowing out has been determined. If a thermal cut-out is used, an element with a maximum tripping current rating 50% greater than motor nameplate Amps. may be selected. Condensate boiler feed pumps are only operating intermittently and therefore it is permissible.

OPERATING INSTRUCTIONS

CAUTION: New or repaired heating systems should be operated several days with the returns open to sewer until water appears clear, in order to thoroughly flush and clean the lines and prevent clogging of the pump when it is put in operation. This may take from a few days to two weeks.

This pump is equipped with a mechanical shaft seal instead of the conventional type of packing. Be sure, therefore, that pump receiver is filled with water or condensate before starting, because the mechanical seal will be damaged if run dry.

LUBRICATION: None required for pump proper. However, the vertical motor is ball bearing type with pre-sealed and lubricated bearings, and no intermediate lubrication is necessary. Required lubrication depends upon service pump is subjected to and cleanliness of location. Normal lubrication — at the start of each heating season or every 1500 hours of operation whichever comes first. **DO NOT** over lubricate. Use CITCO Premium Lithium #2 or equal.

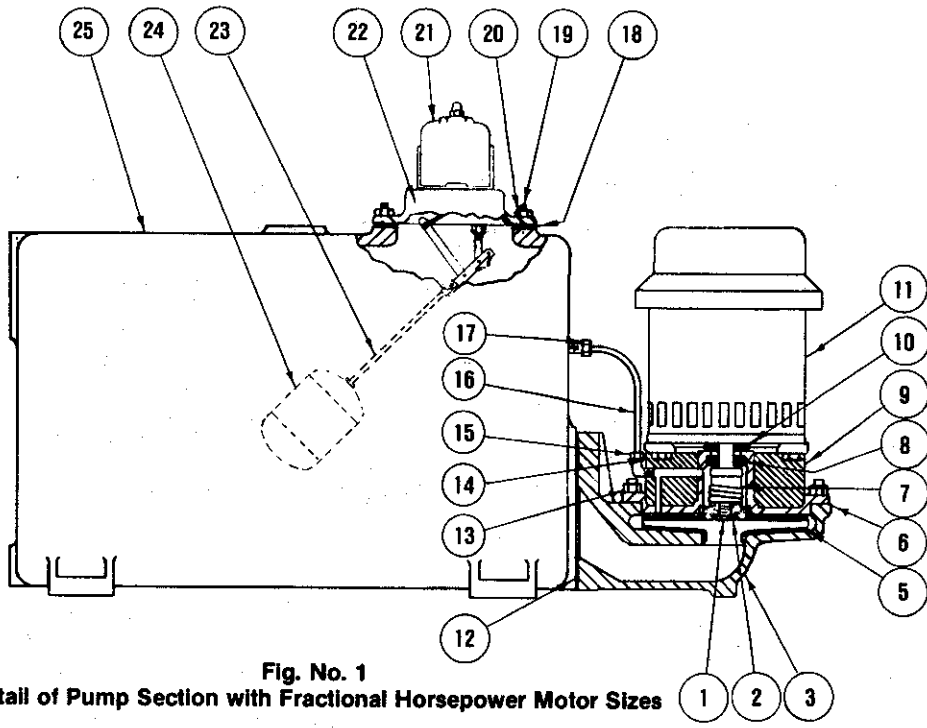

Fig. No. 1
Detail of Pump Section with Fractional Horsepower Motor Sizes

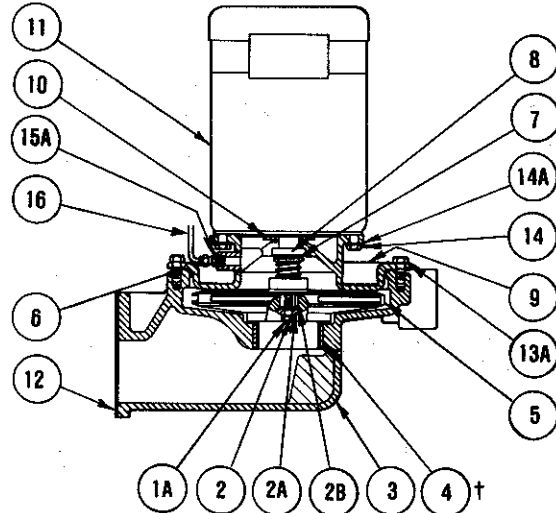

Fig. No. 2
Detail of Pump Section PVES Series

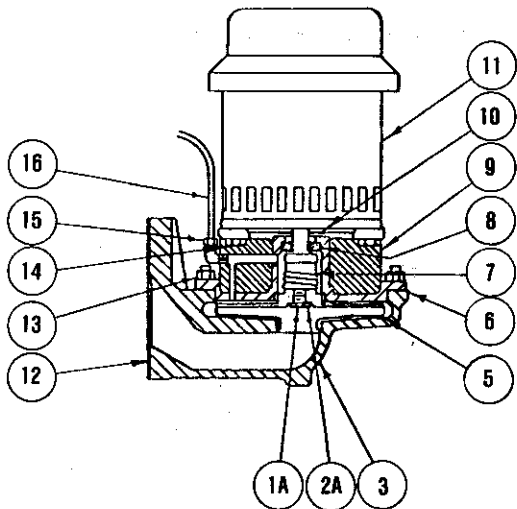

Fig. No. 3
Detail of Pump Section with Integral Horsepower Motor Sizes

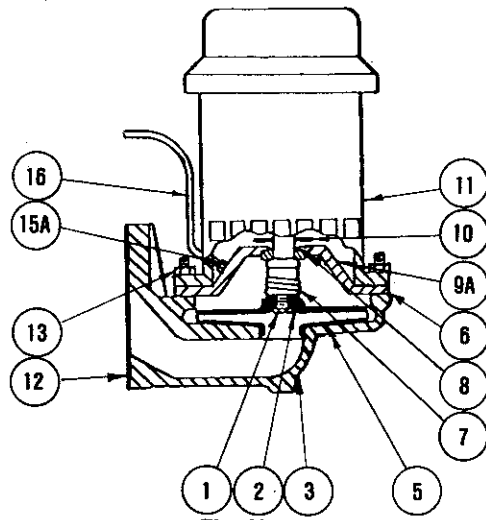

Fig. No. 4
Detail of Pump Section PVJS All Sizes

PARTS LIST

- | | |
|---|--|
| 1 - Impeller Lock Nut — Bronze 30 | 13A* - Hex Head Cap Screw |
| 1A - Impeller Lock Screw — Stainless Steel 10 | 14* - Hex Head Cap Screw |
| 2 - Impeller Lockwasher — Bronze | 14A* - Lockwasher |
| 2A - Impeller Retaining Collar — Bronze | 15 - Vent Line Fitting — Elbow |
| 2B - Impeller Key | 15A - Vent Line Fitting (Seal Plate) |
| 3 - Pump Housing — C.I. | 16 - Pump Vent Line |
| 4† - Wear Ring — Bronze | 17 - Vent |
| 5 - Centrifugal Impeller | 18 - Gasket — Float Switch |
| 6 - Gasket — Pump Housing | 19* - Hex Head Cap Screw (C.I. Only) 4 Reg. |
| 7 - Rotating Seal Assembly with S.S. Spring | 20* - Hex Nut — Float Switch (Steel Only) 4 Reg. |
| 8 - Ceramic Seal Seat and Vibration Ring | 21 - Float Switch Only |
| 9 - Motor Bracket — C.I. | 22 - Float Switch and Linkage Assembly
Complete with Ball and Rod |
| 9A - Seal Plate | 23 - Float Rod |
| 10 - Water Slinger — Neoprene | 24 - Float Ball |
| 11 - Electric Motor | 25 - Receiver |
| 12 - Gasket — Receiver to Pump Housing | |
| 13* - Hex Nut and Stud Bolt | |

*May be purchased locally † PVES only

INSPECTION BEFORE STARTING UNIT FOR FIRST TIME

1. Check motor shaft and be sure it rotates freely. If shaft is tight, inspect pump end and motor for foreign matter clogging pump or lodging in motor.
2. Check voltage supply and be sure it is same as motor on pump, or same as wiring connections made at factory.
3. Be sure piping connections to pump have been made as per instructions and that air vent pipe from receiver is open to atmosphere.
4. Be sure that the engineering characteristics of the complete pump are identical to the capacity, discharge pressure and other requirements of the system.
5. Be sure that the float in the receiver is free to operate float switch.

Starting: Open valves in discharge and return lines, close valves in drain lines and close fused knife switch. If an automatic starter with selector switch is installed, be sure selector switch button is in "Auto" position.

INSPECTION AFTER STARTING

1. With vent pipe open to atmosphere, air and vapor can escape as fast as condensation flows into receiver. If vent is not open, or restricted, receiver will not fill.
2. Be sure pump and motor rotate in proper direction. Correct direction of rotation is CLOCKWISE when looking at top of motor. (If rotation is reversed, refer to motor instruction card and change proper leads.)
3. Check motor bearings for overheating.
4. Check float switch to see that it starts and stops motor as receiver fills and empties.
5. Check all piping connections for leaks.
6. Observe operation of unit closely for several hours after first starting and at regular intervals for several days. A new unit is frequently stiff and bearings are tight and therefore should be watched to check performance.

SERVICE AND CARE OF UNIT

1. Inspection: To insure best operation of unit, make a systematic inspection at least once a week.
2. Cleanliness: Keep the interior and exterior of motor and automatic switches free from moisture, oil and dirt. If necessary, use compressed air for blowing out dirt. Occasionally drain and flush pump receiver to remove sediment and pipe scale.
3. Motor Bearings: Prevent excessive heating and wear of ball bearings by proper lubrication, frequency depending upon service pump is subjected to and cleanliness of location. When bearings are worn and unit becomes noisy, replace worn bearings immediately so as not to injure other rotating parts.
4. Automatic Switches: Occasionally examine contacts of automatic switches and see that they make a full firm contact and break the circuit quickly. Be sure all terminal connections are tight and not corroded.
5. Mechanical Shaft Seal: Occasionally examine water slinger Part No. 10 on motor shaft and look for water leakage. Any leakage will also be visible on Part No. 9 motor bracket. Leakage indicates that the seal surfaces are worn and Parts No. 7 and 8 will need replacing. (For proper procedure in replacing these parts, refer to instructions under Disassembly of Pump.) CAUTION: NEVER OPERATE PUMP WHEN RECEIVER IS EMPTY, BECAUSE THE SEAL WILL BE DAMAGED IF RUN DRY.
6. Shutting Down: At end of heating season, open main line switch, close valves in return line and discharge piping, and drain receiver and pump. If necessary, cover electric motor and automatic switches to protect them against dirt, oil and moisture.
7. Caution: Never operate pump when receiver is empty or expose it to freezing temperature when filled with water.

REMOVING PUMP AND MOTOR UNIT

No return piping or pump discharge piping need be disturbed to remove pump and motor unit, simply proceed as follows:

- 1 - Loosen or remove vent line fittings Parts No. 15 and 17 and swing tube vent line away from pump.
- 2 - Disconnect wiring and flexible conduit at motor terminal box and swing away from pump.
- 3 - Remove nuts No. 13 or hex. head cap screw No. 13A and lift motor and pump unit from pump housing No. 3 for inspection or repair.

DISMANTLING PUMP AND MOTOR UNIT

FOR PUMP UNIT WITH FRACTIONAL H.P. ELECTRIC MOTOR, Proceed as follows:

- 1 - Remove drip cover from top end of motor and receiver plug from center of motor top end-bell. Note slot in top end of motor shaft (or two flats on motor shaft if it extends above end-bell.). Use either a heavy wide blade screwdriver, or open end wrench, to hold motor shaft securely.
- 2 - Remove No. 1 impeller locknut with socket head wrench by turning locknut COUNTER-CLOCKWISE. Also remove bronze lockwasher No. 2.
- 3 - Still holding motor shaft securely, remove No. 5 impeller by turning COUNTER-CLOCKWISE. Impeller hub is threaded and screws onto threaded motor shaft.
- 4 - Remove No. 7 rotating seal assembly with spring by sliding along motor shaft. Spring seats against impeller hub.
- 5 - Remove No. 14 hex. cap screws, holding No. 9 bracket to motor, and remove bracket from motor. VCS only.
- 6 - Water slinger No. 10 is now visible and can be removed.

FOR PUMP UNIT WITH INTEGRAL H.P. ELECTRIC MOTOR, Proceed as follows:

- 1 - Insert blade of screwdriver in one of the peripheral vane openings of impeller to keep shaft from turning. With another screwdriver or socket wrench remove No. 1A impeller lock screw by turning COUNTER-CLOCKWISE. Impeller lock screw may be slotted round head type or hexagon head type. Also remove lockwasher No. 2, if used.
- 2 - Remove No. 2A impeller retaining collar and with two (2) screwdriver blades 180° apart and between impeller No. 5 and bracket No. 9, pry impeller from motor shaft. The impeller hub has a straight bore and motor shaft is straight with a key and keyway. Remove key in motor shaft.
- 3 - Remove No. 7 rotating seal assembly with spring by sliding along motor shaft. Spring seats against impeller hub.
- 4 - Remove No. 14 hex. cap screws, holding bracket to motor, and remove bracket No. 9 from motor. VCS and VES only.
- 5 - Water slinger No. 10 is now visible and can be removed.

REPLACING MECHANICAL SHAFT SEAL AND REASSEMBLING PUMP

- 1 - Pump and motor unit must be completely dismantled as indicated above.
- 2 - Remove No. 8 Ceramic stationary seal seat and vibration ring from bracket No. 9.
- 3 - Be sure counter-bore in bracket No. 9 is perfectly clean before inserting new ceramic seat and ring.
- 4 - Use a light oil on the entire diameter of vibration ring and press it together with the ceramic seat into the machined bore of bracket No. 9. Press as far as it will go and be sure it is in proper place with seat surface at a perfect 90° angle with respect to motor shaft. Use caution so as NOT to SCRATCH or MAR lapped surfaces of ceramic seat.
- 5 - Attach No. 9 bracket to motor and replace screws No. 14.
- 6 - Use light oil on lower end of motor shaft and slip rotating seal assembly No. 7 onto motor shaft as far as it will go. CAUTION: Be careful not to SCRATCH or MAR lapped surface of carbon ring.
- 7 - Insert seal spring and be sure it seats properly against shaft seal.
- 8 - FRACTIONAL H.P. MOTORS: Hold top end of motor shaft with screwdriver or open end wrench and screw impeller No. 5 CLOCKWISE onto motor shaft until it is tight. The seal spring will center itself on hub of impeller and it will be properly compressed for seal tension.
- 9 - Replace lockwasher No. 2 and locknut No. 1 and turn locknut CLOCKWISE until tight.
- 8A - INTEGRAL H.P. MOTORS: Replace impeller key in motor shaft and replace impeller on shaft. With impeller in proper place, the inside hub will be almost flush with end of motor shaft and seal spring will have proper compression.
- 9A - Insert screwdriver blade in one of the impeller peripheral openings to keep it from turning, and replace No. 2A retaining collar, lockwasher No. 2 (if used) and No. 1-A locking screw. Tighten locking screw by turning CLOCKWISE.
- 10 - Replace gasket No. 6 and set pump and motor unit onto pump housing No. 3 and replace stud nuts No. 13 or hex. head cap screws No. 13A and tighten securely.
- 11 - Replace tube vent line No. 16 and tighten fittings No. 15 and 17.
- 12 - Reconnect wiring and flexible conduit at motor terminal box and unit is now ready for operation. (Check rotation.)
- 13 - CAUTION: NEVER RUN PUMP WITH RECEIVER EMPTY, BECAUSE BOTH ELEMENTS OF MECHANICAL SHAFT SEAL WILL BE DAMAGED.