

# REPAIR INSTRUCTIONS

## TYPE AD PUMPS

## FIGURE 5200



Peerless Pump Company  
2005 Dr. Martin Luther King Jr. Street  
Indianapolis, IN 46202  
Phone: (317) 925-9661 • Fax: (317) 924-7388

before attempting to install, operate or repair this pump. Properly installed, your Peerless Pump will give you satisfactory, dependable service. As a safeguard to keeping the warranty valid, we urge that you read carefully these step-by-step instructions, to simplify any problems of installation, operation or repair.

Failure to comply with installation and operating instructions will void the responsibility of the manufacturer and may also result in bodily injury as well as property damage.

This book is intended to be a permanent part of your pump installation and should be preserved in a convenient location for ready reference.

## WARRANTY

The Corporation warrants products of its own manufacture against defects in material and workmanship under normal use and service for a period of not more than one year after date of shipment of the product. The corporation's obligation under this warranty is limited to furnishing or repairing without charge f.o.b. its works, a similar part to replace the part of its own manufacture, which — after not more than one year following shipment of the machinery — is proven to have been defective at the time it was shipped, provided the Purchaser had given the Corporation immediate written notice upon discovery of such defects.

The Corporation shall have the option of requiring the return of the defective material (transportation prepaid) to establish the claim.

The Corporation shall in no event be held liable for damage or delays caused by defective material, shall not be liable for consequential damages in cases of any failure to meet the conditions of any warranty, it being understood the full liability of the Corporation under this clause is the replacement or repair of defective parts as herein before stated.

The Corporation will not be responsible for defects in parts or equipment not manufactured by it, beyond the guarantee of the outside manufacture of such parts.

## SECTION I DISASSEMBLY

### WARNING

Shut down the pump. Temporarily disable the pump drive before starting any repairs. Refer to Bulletin No. 2880549 for the procedure to follow.

1-1. Remove coupling guard. Disengage the drive coupling halves. Refer to the coupling manufacturer's instructions.

1-2. PUMP DISASSEMBLY. (See Figure 1) Disassemble pump to the extent required as follows:

- a. Remove the cap screws from each adapter (71).
- b. Take off all cap screws from upper casing (1B). Remove taper dowel pins. Turn pump jack screw clockwise to separate upper casing from lower casing. After the casings have separated, turn jack screw back so that it will not interfere with the pump reassembly. Using eye bolt and hoist, lift off upper casing.
- c. At the outboard bearing cartridge block (18), remove bearing cover with screw driver by prying outwardly in slot around cover.
- d. Loosen set screws in clamp rings of both bearing cartridge blocks (16 & 18). Do not remove clamp ring or set screws.
- e. Place suitable slings around the shaft (6) near the impeller. Lift the rotating element from lower casing. Place in a convenient work area.
- f. Loosen drive coupling set screw, and tap coupling at back of its hub to remove from shaft. If coupling does not come off easily, use a suitable puller to pull from shaft. Extract coupling key (46).

1-3. ROTATING ELEMENT. Disassemble to the extent required as follows:

- a. Remove the adapters (71) and cartridge blocks (16 & 18) as one assembly.
- b. To remove either cartridge block (16 & 18) from its adapter (71), take out its four attaching cap screws. Support bracket on both sides at larger flange with cartridge on underside. With blunt tool tap around registered fit to remove the cartridge from the adapter. Do not disassemble bearing cartridge block, as it is replaced as a unit assembly.
- c. Remove water deflector.
- d. Remove snap ring from end of each shaft sleeve.
- e. Remove stuffing box (83) as an assembly with gland (17), gland bolts (17B), packing (13), lantern rings (29) in place.
- f. Remove "O" ring from "OD" of each stuffing box.
- g. Remove casing rings (7) from impeller (2).
- h. Remove impeller (2) and impeller key (32) from shaft (6).

1-4. CLEANING. Clean all metal parts (except bearings) with a solvent. Use a bristle brush (NOT metal or wire) to remove tightly adhering deposits. A fiber scraper may be used to remove the gasket and shellac from casing flanges. Blow dry with clean dry compressed air.

- a. Check bearings as described in Bulletin No. 2880549. Do not remove bearings from cartridge blocks.

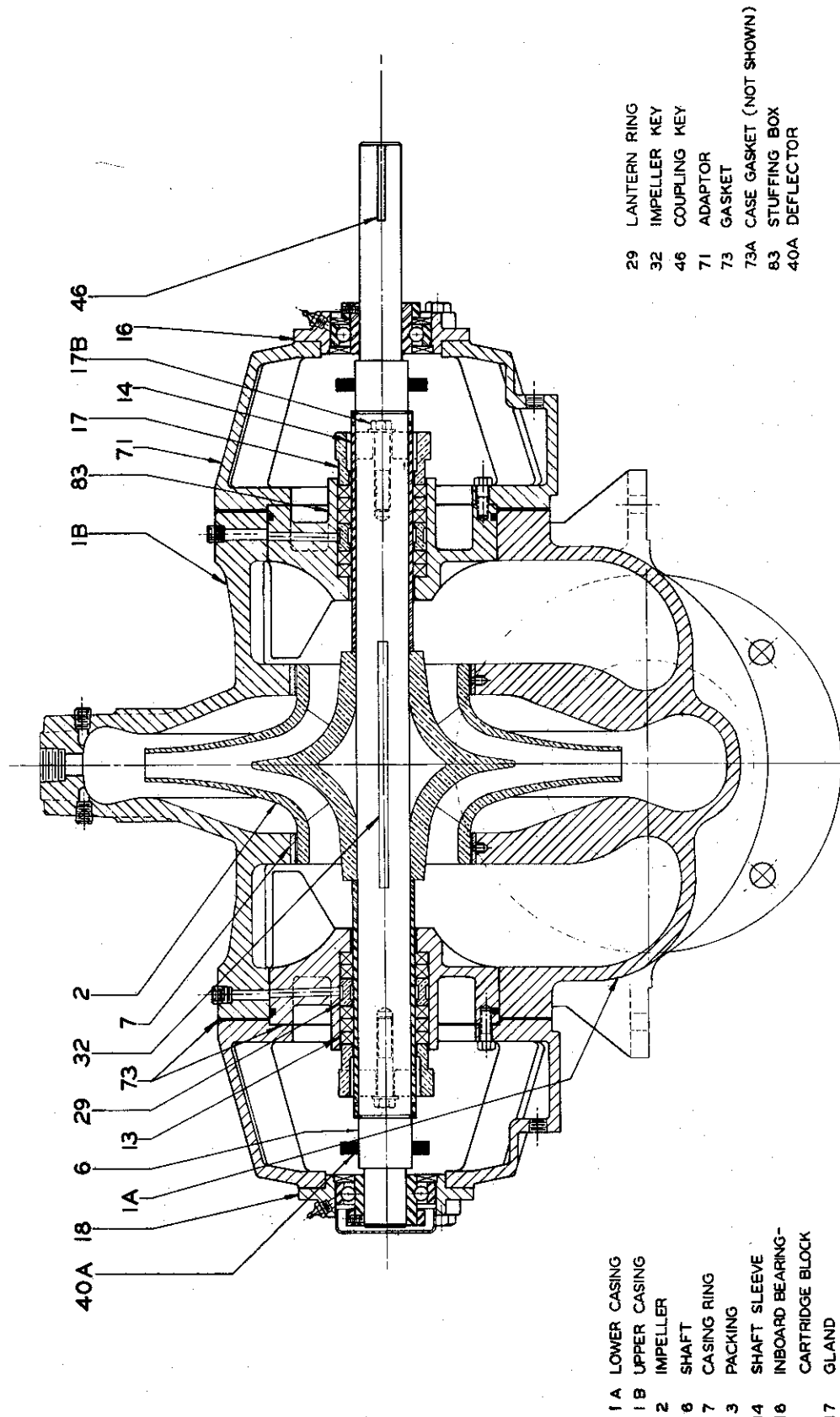

- 1 A LOWER CASING
- 1 B UPPER CASING
- 2 IMPELLER
- 6 SHAFT
- 7 CASING RING
- 13 PACKING
- 14 SHAFT SLEEVE
- 16 INBOARD BEARING-CARTRIDGE BLOCK
- 17 GLAND
- 17B GLAND BOLT
- 18 OUTBOARD BEARING-CARTRIDGE BLOCK
- 29 LANTERN RING
- 32 IMPELLER KEY
- 46 COUPLING KEY
- 71 ADAPTOR
- 73 GASKET
- 73A CASE GASKET (NOT SHOWN)
- 83 STUFFING BOX
- 40A DEFLECTOR

AD' FIGURE 5200

DRAWING NO. 2692993

FIGURE 1.

## SECTION II INSPECTION AND REPAIR

2-1. **INSPECTION.** Visually inspect parts for damage affecting serviceability or sealing. Emphasize inspection of mating parts having relative motion — wear rings, for example. Perform detailed inspection as follows:

- a. Check "O" rings and gaskets for shrinkage, cracks, nicks, or tears. The gasket at the case split must be flush with bore at area of stuffing box (83) to obtain effective seal. When case split is open for any length of time gasket will shrink.
- b. Check packing rings for excessive compression, fraying, or shredding, embedded particles (dirt or metal). Replace if defective in any way.
- c. Mount the shaft between the lathe centers. Check the eccentricity throughout the entire length with a dial indicator to be not more than 0.003 inch total indicator reading. Surfaces on which bearings mount must be smooth, have a finish not less than 63 microinches and the shoulders square and free from nicks.
- d. Measure the OD of the impeller wearing surface, and the ID of the casing ring (7). Compute the diametrical clearance (ID minus OD) and compare the difference with the limits given in Bulletin No. 2880549. ID surface of casing rings and OD of impeller ring must be smooth and concentric.
- e. Examine impeller passages for cracks, dents, gouges or embedded material.

f. For Packed-Type pumps, inspect shaft sleeves (14) for excessive wear. Replace sleeves that are worn. Replace packing.

2-2. **REPAIR.** Make needed repairs in the following manner:

- a. If ID of casing ring (7) is grooved, scored, or eccentric, replace case ring. Check Bulletin 2880549 for diametrical clearance between impeller and case rings. Add 0.030 for maximum allowable clearance.
- b. If diametrical clearance is not within limits, the clearance can be restored by installing impeller wear rings on OD of impeller wearing surface.

### NOTE

If impeller wear rings were previously installed, remove old rings by turning in a lathe; be sure machining is concentric with impeller ID. Use care not to reduce impeller ring skirt OD. If no rings were installed on impeller skirt, turn OD to diameter shown for Model (see Figure 2).

(1) Heat wear rings to a temperature that will enable the ring to drop onto the machined impeller skirts. The ID is factory machined for proper fit. Allow the assembly to cool to room temperature.

(2) After installation, machine the wear rings OD to provide the nominal diametrical clearance shown in Bulletin No. 2880549.

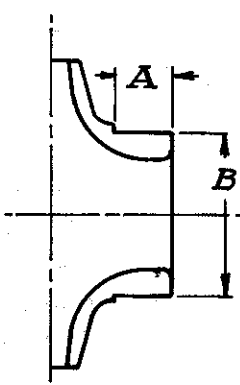

PUMP SIZE	REPAIR DIMENSIONS (INCHES)	
	A	B
1-1/2 AD 9	3/4	3.250/3.248
2 AD 8		
2 AD 11		
3 AD 10		
2-1/2 AD 13	3/4	4.000/3.998
3 AD 8		
3 AD 12		
3 AD 15-1/2	1	4.750/4.748
4 AD 8		
4 AD 9-1/2		
4 AD 14		
4 AD 11-1/2		
4 AD 11	1	5.385/5.383

PUMP SIZE	REPAIR DIMENSIONS (INCHES)	
	A	B
6 AD 7-1/2	1-1/4	6.500/6.498
6 AD 8-1/2		
6 AD 10		
6 AD 14		
4 AD 18-1/2	1-1/8	5.385/5.383
6 AD 11-1/2		
6 AD 9-1/2	1-1/8	5.875/5.873
6 AD 16-1/2		
6 AD 11	1-1/4	7.125/7.123
8 AD 9	1-1/2	7.875/7.873
8 AD 9-1/2		
8 AD 11		
8 AD 13-1/2		
8 AD 17		
10 AD 11	1-1/2	9.250/9.248
10 AD 11-1/2		
10 AD 13-1/2		

FIGURE 2. IMPELLER DIMENSIONS FOR WEAR RING INSTALLATION

SECTION III  
REASSEMBLY

3-1. ROTATING ELEMENT.

- a. Coat shaft (6) lightly with oil. Place impeller key (32) in shaft slot. Install impeller (2) on shaft. Center impeller hub on key (32) as closely as possible. Check impeller to make sure that vanes will rotate in proper direction. (See Figure 3).
- b. Slide one casing ring (7) over each impeller ring skirt.
- c. Install one "O" ring in each shaft sleeve (14) in groove provided. Slide slot end of shaft sleeve over shaft first and locate around key ends which extend beyond impeller.
- d. With hoist and sling, lower Rotating Element into Lower Casing (1A).
- e. To locate case rings (7), Rotate until ring pin matches hole in lower casing ring bore.
- f. Make assembly of Adapter (71), Stuffing Box Gasket and Stuffing Box (83) using the four cap screws provided. To this assembly install gasket (73) against back of Adapter and "O" ring in groove provided in stuffing box.
- g. Place one Adapter assembly over each end of Shaft. Using two cap screws, draw to within 1/16 inch of Casing. (This is to allow Upper Casing to be lowered into place on Lower Casing).
- h. Use upper case as template to cut a casing gasket (73A) from 1/64-inch vellumoid or equal. Shellac the new case gasket to lower case (1A). (Be sure gasket is flush with bore where stuffing box (83) locates; if gasket is not flush "O" ring will not seal at this area.) Coat top of gasket with a mixture of graphite and oil.

- i. Install upper case (1B) on lower case (1A). Be sure case splits are flush. Insert dowel pins for positive location of bores. Secure upper case (1B) to lower case (1A) with cap screws and tighten alternately and diagonally at opposite locations. Tighten cap screws which attach adapter to case.
- j. Install snap ring in grooves provided in shaft (6) at end of each sleeve.
- k. Install water deflector (40A).
- l. Assemble bearing cartridge block (18) in each adapter (71), and use cap screws to attach the inboard and outboard bearing cartridge blocks to each adapter so that the grease fitting will be on top when adapter (71) is assembled on pump (be sure cartridge block with cap is on outboard end) and install coupling half on shaft. Adjust shaft laterally by moving shaft until outboard end of shaft is flush with face of outboard bearing cartridge block (18). Tighten set screws in collars on cartridge bearings. Rotate shaft by hand to see if it runs free.
- m. For Packed-Type pump, insert two rings of packing (13), lantern ring halves (29), three rings of packing (13) and gland (17) in each packing box. Insert each packing ring separately and stagger joints of successive packings 90°. Tighten attaching bolts (17B) finger tight. DO NOT USE A WRENCH. See Figure 4 for packing box dimensions.
- n. Replace any drain plugs that were removed during disassembly.
- o. Relubricate the bearings per Bulletin No. 2880549.
- p. Replace coupling guard.

3-2. TEST. Follow instructions in Bulletin No. 2880549 to check out the pump after repair.

**NOTICE:** Materials of construction, specifications, dimensions, design features, and application information, where shown in this bulletin, are subject to change and/or modification without notice by FMC Corporation Pump Division at their option.

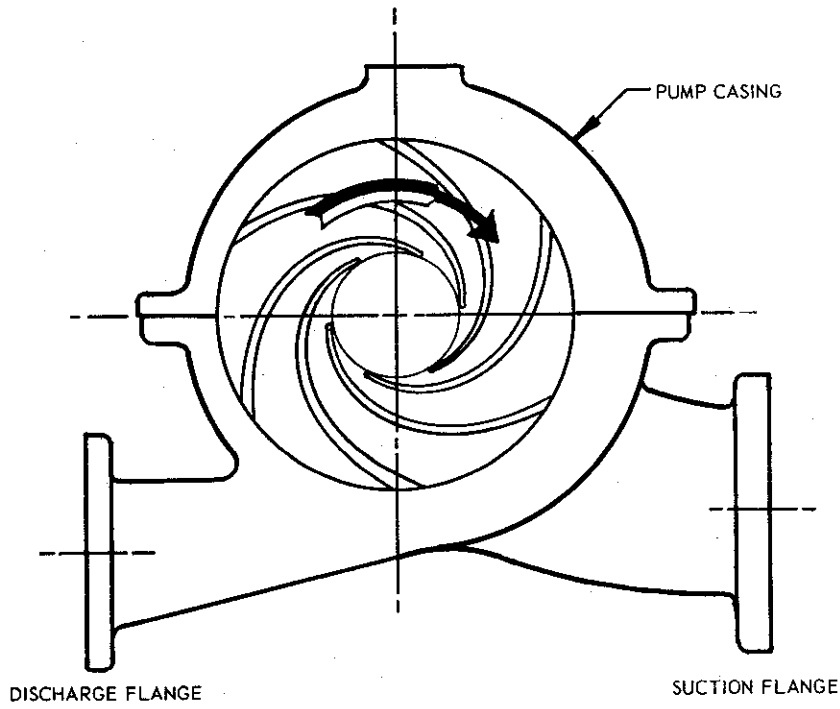

FIGURE 3. VANE POSITION FOR PROPER ROTATION.

GREASE LUBRICATED COUPLING	
Temperature Range	Recommended Grease
-20° to 150° F	Sodium or Lithium soap Type NLG1 No. 2 or ASTM worked penetration 250 - 300
+150° to 250° F	Lithium soap Type grease NLG1 No. 3 or ASTM worked penetration 200 to 250

OIL LUBRICATED COUPLING	
Temperature Range	Recommended Oil
-20° to 300° F	Mineral base oil with viscosity minimum of 150 SSU maximum 1000 SSU at 210° F.

COUPLING LUBRICATION		
Type Coupling	Type Lubrication	Frequency of Lubrication
Falk	Grease	6 Months
Fast	Grease - Oil	6 Months
Sier-Bath	Grease	6 Months
Waldron	Oil	6 Months
T. B. Wood's	No Lubrication Required	

## SECTION IV REPAIR PARTS

4-1. Refer to the following list for commercial repair parts available from local outlets.

PUMP SIZE	RETAINING RING FOR FIG. 5200 ONLY	SHAFT SLEEVE O-RINGS FIG. 5200 ONLY	STUFFING BOX O-RINGS	BALL BEARING FLANGED CARTRIDGE TYPE	
				OUTBOARD	INBOARD
1-1/2 AD 9 2 AD 8 2 AD 11 2-1/2 AD 13 3 AD 8 3 AD 10	TRUARC External Series 5100-118  Peerless Part No. 2612147	Precision Rubber No. 123 or Equal Material-Buna "N"  Peerless Part No. 2669968	Parker Seal Co. No. 2-158 or Equal Material-Buna "N"  Peerless Part No. 2631869	Link Belt FC3-U218 NC or Equal Closed End BRG. Peerless Part No. 2669966	Link Belt FC3-U218 N or Equal  Peerless Part No. 2669965
3 AD 12 3 AD 15-1/2 4 AD 8 4 AD 9-1/2 4 AD 11 4 AD 14	TRUARC External Series 5100-150	Precision Rubber No. 128 or Equal Material-Buna "N"	Parker Seal Co. No. 2-164 or Equal Material-Buna "N" Peerless Part No. 2631870	Link Belt FC3-U2E20 NC or Equal Closed End BRG.  Peerless Part No. 2669893	Link Belt FC3-U2E20 N Or Equal  Peerless Part No. 2669892
6 AD 8-1/2 6 AD 10 6 AD 11	Peerless Part No. 2612151	Peerless Part No. 2669896	Parker Seal Co. No. 2-265 or Equal Material-Buna "N"		
4 AD 11-1/2 4 AD 18-1/2 6 AD 9-1/2 6 AD 11-1/2 6 AD 14 6 AD 16-1/2	TRUARC External Series 5100-196	Precision Rubber No. 135 or Equal Material-Buna "N"	Peerless Part No. 2611908	Link Belt FC3-U227 NC or Equal Closed End BRG. Peerless Part No. 2669937	Link Belt FC3-U227 N or Equal  Peerless Part No. 2669938
8 AD 9-1/2 8 AD 11	Peerless Part No. 2612158	Peerless Part No. 2669940	Precision Rubber No. 377 or Equal Material-Buna "N"		
8 AD 13-1/2 8 AD 17 10 AD 11-1/2 10 AD 13-1/2	TRUARC External Series 5100-225  Peerless Part No. 2612162	Precision Rubber No. 140 or Equal Material-Buna "N"  Peerless Part No. 2671944	Peerless Part No. 2671943	Link Belt FC3-U231 NC or Equal Closed End BRG. Peerless Part No. 2671926	Link Belt FC3-U231 N or Equal  Peerless Part No. 2671925

4-2. Figure 4 gives pertinent dimensions for packing used in Packed-Type AD Figure 5200 Pumps. Refer to Bulletin No. 2880549 for specifications of suitable packings which may be installed.



**Peerless Pump Company**

2005 Dr. Martin Luther King Jr. Street

Indianapolis, IN 46202

Phone: (317) 925-9661 • Fax: (317) 924-7388