



Horizontal Centrifugal Pump Installation, Operation and Maintenance Manual



SECTION 1 SAFETY INSTRUCTIONS.....2

SECTION 2 INTRODUCTION.....5

SECTION 3 INSTALLATION5

 LOCATION5

 FOUNDATION5

 MOUNTING AND LEVELING6

 ALIGNMENT6

 GROUTING8

 PIPING.....8

 DRIVER9

 DOWELING10

SECTION 4 LUBRICATION16

 COUPLINGS16

 BEARINGS.....16

 RELUBRICATION16

 STUFFING BOX.....17

SECTION 5 OPERATION18

 PRIMING18

 STARTING.....18

 SHUT DOWN.....19

APPENDIX 1 LONG TERM STORAGE.....21





SECTION 1 Safety Instructions

Read this entire bulletin

before attempting to install, operate or repair this pump. Properly installed, your Peerless Pump will give you satisfactory, dependable service. We urge that you read carefully these step-by-step instructions, to simplify any problems of installation, operation, or repair.

GENERAL SAFETY INSTRUCTIONS

- Failure to read and comply with installation and operating instructions will void the responsibility of the manufacturer and may also result in bodily injury as well as property damage. Peerless Pump requires that all personnel that are responsible for installation, operation, or maintenance of the equipment, have access to and study the product instruction manual(s) BEFORE any work is done and that they comply with all local and industry based safety instructions and regulations.
- The bearing structure in all Peerless Pump horizontal products is not designed to accept external loads from belt drive arrangements. When it is necessary to belt drive the pump, the customer must provide a separate jack-shaft with a bearing structure suitable for the intended belt loading.
- This bulletin is intended to be a permanent part of your pump installation and should be preserved in a convenient location for ready reference. If these instructions should become soiled, obtain a new copy from Peerless Pump. Include pump model an/or serial number with your request. The following documents are also considered part of the instructions for use for this installation and should be maintained in the same way.
 - Repair instructions for the pump that are covered in a separate bulletin,
 - The performance curve (if supplied),
 - Outline drawing(s), and
 - Declaration of Conformance or Incorporation (if supplied).
 - Any other document that contains information concerning intended use or limits of use of this unit.
- This pumping unit is designed to be operated within certain limits pertaining to fluid pump, driver conditions, etc. (see SECTION 14 below). These limits are listed on the performance curve, or on original contract documentation. Operation outside of these limits may result in damage to the unit, personal injury, or death. Consult your Peerless Pump representative for approval if a need arises to operate outside of these limits.
- Do not remove or paint over any safety labels. If labels are lost or damaged, contact your Peerless Pump representative for replacement.
- Do not exceed the forces or moments specified on the outline drawing when connecting piping to the suction or discharge flanges.
- The area around the pump unit must be kept clear of debris to reduce the possibility of fire or explosion due to debris coming into contact with hot surfaces of the unit.
- Do NOT operate the unit with any of the supplied guarding removed or disabled.
- Ensure that the driver is disabled and/or locked out when servicing the pump or coupling.
- Access to the equipment should be restricted to the personnel responsible for installation, operation, and maintenance. These personnel must be trained, adequately qualified, and supplied with the appropriate tools for their respective tasks.
- STERLING FLUID SYSTEMS requires that all personnel that are responsible for installation, operation, or maintenance of the equipment, have access to and study the product instruction manual(s) BEFORE any work is done and that they will comply with all local and industry based safety instructions and regulations.
- Do NOT wear loose or frayed clothing or jewelry that could catch on the controls or become trapped in the equipment.

MECHANICAL HAZARDS

CRUSHING HAZARDS

- Use only qualified personnel (riggers) to lift or move unit at any time.
- Never lift unit using hooks or slings on shafts.
- Never place eyebolts in tapped holes except for removal of a part to perform service work (i.e. Use eyebolt in tapped hole in upper case half only to lift upper case half, not to lift entire pump).
- Use proper lifting techniques when manually lifting components – keep component close to body, back straight, lift with legs, DO NOT BEND AT WAIST.
- Do not place hands under component in such a way that the component would fall on the hands if dropped.





SHEARING HAZARDS

- Do NOT place fingers, hands, arms, etc. into the suction or discharge openings or into any other opening (such as the air relief valve hole). Do NOT touch the impeller, if rotated, this can cause severe injury. To prevent ingress of any objects, retain the protective covers or packaging in place until removal is necessary for installation. If the packaging or suction or discharge covers are removed for inspection purposes, replace afterwards to protect the pump and maintain safety.

ENTANGLEMENT HAZARDS

- The area between the stuffing box and bearing bracket is left open to allow for inspection and adjustment of packing. Do NOT place hands or fingers into this area. Do NOT wear loose clothing, long hair, or jewelry around this area. Failure to abide by this requirement could result in entanglement or friction burns.

IMPACT HAZARDS

- Do not use excessive force when adjusting packing glands as wrench slippage can result in impact of the hand against the casing.

ELECTRICAL HAZARDS

- Use only qualified electricians for electrical installation and maintenance.
- Refer to manuals provided with electrical components and disconnect power supply as recommended for servicing.
- Ground the unit according to local codes.

THERMAL HAZARDS

- Most surfaces on the driver (engine or motor) can become hot during normal operation. The stuffing box and bearing bracket areas on the pump can become hot in the event of a malfunction or maladjustment. These surfaces may remain hot for some time after the unit has been shut down. Use care when touching these surfaces and wear protective gloves if necessary to touch these surfaces when hot.
- If packing is too tight, the drain water from the stuffing box can become hot enough to scald. Ensure that drain water is not excessively hot before extensive contact.

NOISE HAZARDS

- Noise levels, especially for diesel engine driven units, can exceed safe levels. Refer to the noise level published in the accompanying documentation, and, if this noise level exceeds local code or safe levels, place the unit in a controlled access area and provide ear protection to personnel authorized to be in this area.
- Fire pump units can start unexpectedly at any time. If the published noise level for a fire pump unit is above safe levels, ear protection should be carried by, or readily available to, all personnel authorized to be in the pump room with these units.

PERSONAL PROTECTIVE EQUIPMENT

- Wear eye protection at all time in the vicinity of the unit. Wear ear protection when loud units are running.

DRIVER HAZARDS

- Refer to the manual(s) provided for the driver for specific hazards. General driver hazards are discussed below.

MOTOR HAZARDS

- Isolate the equipment before any maintenance work is done. Switch off the mains supply, remove fuses, apply lock-outs where applicable and affix suitable isolation warning signs to prevent inadvertent re-connection.
- The motor can become hot during normal operation. These surfaces may remain hot for some time after the unit has been shut down. Use care when touching these surfaces and wear protective gloves if necessary to touch these surfaces when hot.
-

DIESEL ENGINE HAZARDS

- ISOLATE the equipment before any maintenance work is done. Switch off the main supply, remove fuses, apply lock-outs where applicable, and affix suitable isolation warning signs to prevent inadvertent re-connection.
- DISCONNECT the batteries by removal of the NEGATIVE terminal connector.
- Do NOT place tools on or near the batteries. This could result in a short circuit.
- INSPECT all cables for damage or signs of failure and replace immediately if damaged.
- Most surfaces on the engine can become hot during normal operation. These surfaces may remain hot for some time after the unit has been shut down. Use care when touching these surfaces and wear protective gloves if necessary to touch these surfaces when hot.
- Wear or carry ear protection when working near the engine even if it is not running, as it may start unexpectedly if fitted with an automatic start control system.





- FUEL FUMES ARE HIGHLY FLAMMABLE! Do NOT refuel the engine when it is running or is still hot from recent running.
- When refueling, avoid breathing the fuel fumes, particularly if the pump; is installed in an enclosed pump room. Maintain maximum ventilation to clear the fumes quickly.
- Do NOT start the engine while fuel fumes remain evident or may be present.
- Exhaust gases are hazardous; the exhaust system MUST be maintained free from leaks and directed to discharge in a safe area.
- Battery gasses are hazardous and flammable. The battery area MUST b well ventilated to clear these gases quickly.
- Do NOT store lubricants or other volatile substances near the engine. These should be placed in a designated area having a suitable storage enclosure.
- ISOLATE the fuel supply to the engine BEFORE working on any part of the fuel supply or control system.

Throughout the balance of this manual, safety instructions are marked with the following symbols:

Safety Instructions for general mechanical aspects which must be complied with to ensure the required level of safety, are identified by the symbol:



Where electrical safety is involved, the safety instructions are identified by the symbol:



Safety Instructions, which shall be considered for reasons of safe operation of the pump or pump unit and/or protection of the pump or pump unit itself, are marked by the symbol:



WARRANTY

New equipment manufactured by Seller is warranted to be free from defects in material and workmanship under normal use and service for a period of one year from date of shipment; Seller's obligation under this warranty being limited to repairing or replacing at its option any part found to its satisfaction to be so defective provided that such part is, upon request, returned to Seller's factory from which it was shipped, transportation prepaid. This warranty does not cover parts damaged by decomposition from chemical action or wear caused by abrasive materials, nor does it cover damage resulting from misuse, accident, neglect, or from improper operation, maintenance, installation, modification or adjustment. This warranty does not cover parts repaired outside Seller's factory without prior written approval. Seller makes no warranty as to starting equipment, electrical apparatus or other material not of its manufacture, since the same are usually covered by warranties of the respective manufacturers thereof.

In the event, notwithstanding the terms of this agreement, it is determined by a court of competent jurisdiction that an express warranty has been given by Seller to Purchaser with respect to the head, capacity or other like performance characteristics of said equipment. Seller's liability for breach of the same shall be limited to accepting return of such equipment F.O.B. plant of manufacture, refunding any amount paid thereon by Purchaser (less depreciation at the rate of 15% per ear if Purchaser has used equipment for more than thirty (30) days) and canceling any balance still owing on the equipment.

This warranty is expressly in lieu of any other warranties, expressed, or implied, and Seller specifically disclaims any implied warranty of merchantability or fitness for a particular purpose.

See grouting requirement on page 8.



SECTION 2 INTRODUCTION

1. This bulletin provides general instructions for the installation and operation of horizontal, centrifugal pumps manufactured by Peerless Pump, Indianapolis, Indiana.
2. After carefully uncrating or unpacking, check the equipment against the shipping papers and inspect for damage incurred during shipment. Immediately notify the carrier of any damage or shortage found.
3. If the pump is not to be installed immediately, it should be stored in a clean, dry area with protection from moisture, dust, dirt, and foreign bodies. For detailed instructions on long-term storage, see APPENDIX 1 at the end of this manual.
4. The type and size of pump was selected to meet requirements specified by purchaser. Among the more important are these:
 - Type of Liquid Pumped
 - Temperature, Viscosity, Specific Gravity
 - Flow Rate
 - Suction Pressure or Lift
 - Total Head
 - Type Driver
 - Motor and its electric power supply characteristics
 - Engine
 - Steam turbine and its steam supply and exhaust conditions
 - Other (as described)

ATTENTION

If any one of these requirements has changed since the order was placed, particularly the suction condition, we strongly recommend that such change be reviewed with the Peerless Pump representative. If the performance curve previously furnished has been lost, the representative will furnish another copy.



Do not operate this pump at any pressure, flow rate, or liquid temperature other than those for which the pump was originally purchased. Do not pump any other liquid than the one for which the pump was originally purchased without the consent of Peerless Pump or its authorized representatives. Disregard of this warning can result in pump failure and serious personal injury or death.

ATTENTION

Operation of the pump under conditions differing widely from those for which the pump selection was based may result in reduced parts life.

- Inadequate NPSH at any capacity will result in cavitation damage to the impeller and casing.
- Operation at a reduced capacity for prolonged periods may shorten the useful life of the seals or packing, shaft sleeves, bearings, and the shaft. Fire pumps are applied with full knowledge that operation at reduced capacity will occur.

SECTION 3 INSTALLATION

LOCATION

1. Select a location for the pumping unit (pump, base plate, coupling, and driver) that will:
 - Be clean, well ventilated, properly drained and provide accessibility for inspection and maintenance (see outline drawing for dimension). Outdoor installations may require protection from the elements, particularly freezing.
 - The suction supply system must provide the pump with Net Positive Suction Head (NPSH) equal to or greater than that required by the pump at any capacity on its operating curve. Ask your Peerless Pump representative for assistance if; you do not understand how to calculate or measure suction supply system NPSH.

FOUNDATION

2. Concrete, (reinforced as necessary or required) is most widely used for the foundation. In sufficient mass, it provides rigid support, which minimizes deflection and vibration. It may be located on soil, structural steel or building floors, provided the combined weight of the pumping unit and foundation does not exceed the allowable bearing load of the support. Allowable bearing loads of structural steel and floors can be obtained from engineering handbooks; building codes of local communities give the recommended allowable bearing loads for different types of soil.

3. Before pouring the foundation, locate the foundation bolts by the use of a template frame and provide anchorage as shown in Figure 1. See the outline drawings furnished with each pump for the exact location of the foundation bolts. When pouring, allow for a grout thickness of $\frac{3}{4}$ to $1\frac{1}{2}$ inch. Roughen top surface to provide a good bond of the grout. Ordinarily, the proportions used are 1 part cement to 3 parts sand and 4 parts medium aggregate.

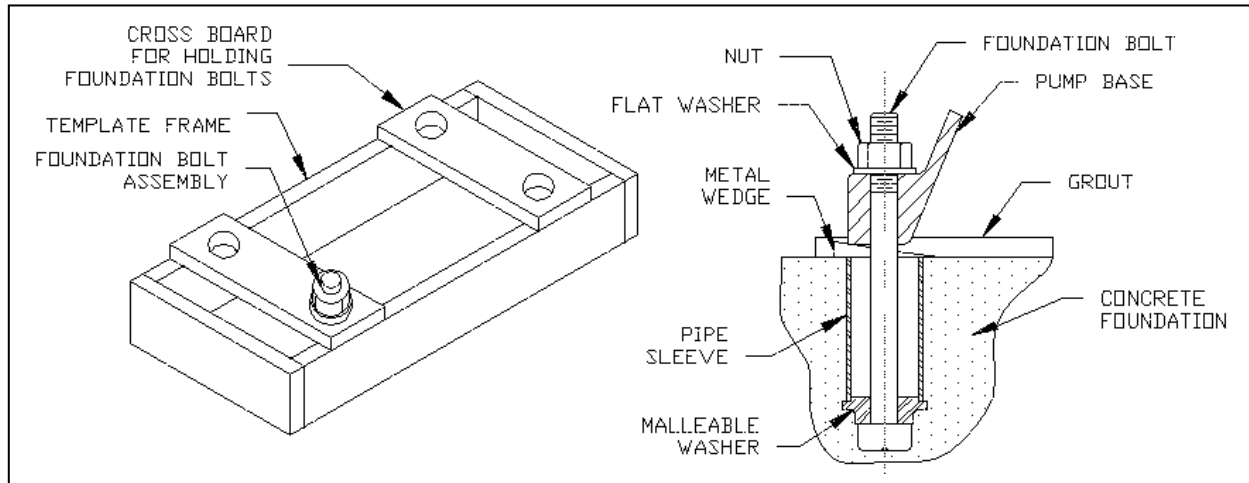

Figure 1 FOUNDATION BOLT LOCATION AND ANCHORAGE

MOUNTING AND LEVELING

CAUTION

4. Use qualified personnel (riggers) to lift or move unit at any time. Never lift unit using hooks or slings on shafts. Never place eyebolts in tapped holes except for removal of a part to perform service work.



5. When the unit is received with the pump and the driver mounted on the base plate, it should be placed on the foundation and the coupling halves disconnected. The coupling should not be reconnected until the alignment operations have been completed. The base plate should be supported on rectangular metal blocks and shims or on metal wedges having a small taper. The support pieces should be placed close to the foundation bolts (Figure 2). On large units, small jacks made of cap screws and nuts are very convenient. In each case the supports should be directly under the part of the base plate carrying the greatest weight and spaced closely enough to give uniform support. A spacing of 24 inches is suggested on medium size units. A gap of about $\frac{3}{4}$ inches to $1\frac{1}{2}$ inch should be allowed between the base plate and the foundation for grouting.

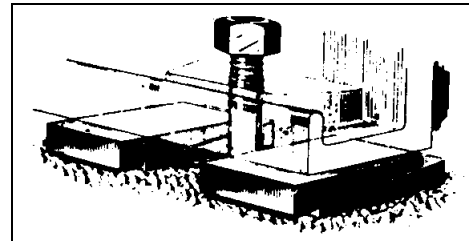

Figure 2 ADJUSTING WEDGES FOR MOUNTING

6. Adjust the metal supports or wedges until the shafts of the pump and driver are level. Check the coupling faces as well as the suction and discharge flanges of the pump for horizontal or vertical position by means of a level. Correct the positions, if necessary, by adjusting the supports or wedges under the base plate as required.

7. Pumps and drivers mounted on a common base plate were accurately aligned before shipment. **All base plates are flexible to some extent and, therefore, must not be relied upon to maintain the factory alignment.**

8. Realignment is necessary after the complete unit has been leveled on the foundation and again after the grout has set and foundation bolts have been tightened. The alignment must be checked after the unit is piped and rechecked periodically as outlined in the following paragraphs. To facilitate accurate field alignment, we do not dowel the pumps or drivers on the base plates before shipment.

ALIGNMENT

9. Reliable, trouble-free, and efficient operation of a pumping unit requires correct alignment of pump and driver shafts. Misalignment may be the cause of:

- Noisy pump operation
- Vibration
- Premature bearing failure

- Excessive coupling wear

10. Factors that may change the alignment of the pumping unit are:

- Setting of the foundation
- Springing of the base plate
- Piping strains
- Settling of the building
- Shift of pump or driver on the foundation

11. The following checking procedure applies to a pumping unit consisting of a pump, flexible coupling, and driver mounted on a common base plate. Check alignment as follows:

- Disconnect the coupling halves.
- Set the coupling gap to the dimension shown in Table 1, Table 3, or on outline drawings.
- Test for parallel and angular alignment with a straight edge and feeler gauge as shown in manufacturer's instructions (at the end of this section). With coupling halves stationary, make trials at four places 90° apart. Perfect alignment occurs when a straight edge is level across the coupling halves and the same gauge just enters between the halves, both conditions at all points.
- An alternate test for parallel and angular alignment may be made with a dial indicator mounted as shown in Figure 3. Proceed as follows:
 - Scribe the index lines on the coupling halves (as shown) or mark where the indicator point rests.
 - Set indicator dial to zero.
 - Slowly turn BOTH coupling halves so that index lines match, or indicator point is always on the mark.
 - Observe dial reading to determine whether pump or driver needs adjustment.
 - Acceptable parallel and angular alignment occurs when total indicator reading (complete turn) does not exceed limits shown on either a tag or decal on the unit or on the unit outline drawing.

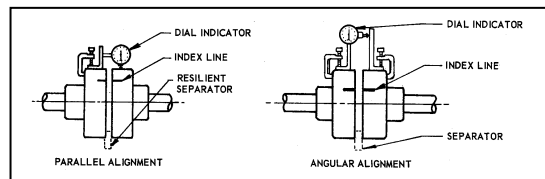

Figure 3 TESTING ALIGNMENT, DIAL INDICATOR

12. When significant operating temperature differential will exist between the pump and driver (i.e. steam turbine drive with pump handling cold liquid), thermal growth will cause the hotter unit to rise. Compensate for this growth by initially setting the hotter unit 0.003 inch to 0.005 inch low. When both units are at normal operating temperature, a final check of coupling alignment must be made. Correct the alignment if necessary.

NOTE

Check for correct electric motor rotation as described in the two bullet points under paragraph 23 below while coupling halves are disconnected.

13. Correct for excessive parallel and angular misalignment by slightly shifting the leveling wedges under the baseplate. Tap lightly (in or out) with a hammer. Retest alignment after each shifting of a wedge.

- In some instances, for factory-aligned pumping units, it may be necessary to change the shims under the pump or driver, or even relocate these factory-positioned units on the base plate. Make such changes only after it is certain alignment cannot be obtained by shifting of the wedges.
- If wedges are shifted or shims changed a substantial amount to obtain proper alignment, recheck the piping alignment and level of the shafts.

NOTE

Pumping unit shafts must be level, have proper alignment and the piping must mate with the pump flanges without strain. All three conditions must be correct to provide proper performance and long life of the pumping unit.

14. Recheck alignment, and correct as required, after:

- Mounting
- The grout has hardened
- Foundation bolts are tightened,
- Piping is connected
- Pump, driver, or base plate is moved for any reason.



GROUTING

15. Unless otherwise specified on the unit outline drawing, the base plate must be completely filled with grout and the leveling wedges grouted in place. The product warranty is void if this instruction is not followed.

16. When the alignment is correct, the foundation bolts should be tightened evenly but not too firmly. The unit can then be grouted to the foundation. Foundation bolts should not be fully tightened until the grout is hardened, usually about 48 hours after pouring. Installation without grout completely filling the base plate is acceptable only when recommended by specific notation on the unit outline drawing.

17. Grouting that completely fills a base plate is also necessary for minimum vibration levels, since a very stiff base is uneconomical and unnecessary except for portable units. Grout compensates for unevenness in the foundation and base plate and distributes the weight of the unit uniformly over the foundation. It also prevents the unit from shifting after mounting and alignment. It is essential that the pumping unit be expertly grouted by use of non-shrinking grout. The mix required varies with the type of unit to be grouted, location, and amount of grout. The instructions included with the non-shrinking grout package will provide the required information for the proper mix for individual applications. Grout the unit as follows:

- Build a form of plywood or thick planking around the foundation to contain the grout. Support adequately to prevent deformation.
- Follow the grout manufacturer's recommendations for proper surface preparation.
- Pour the grout through the holes provided in the base plate or through open ends of steel channel base plates. While pouring, tamp liberally in order to fill all cavities and prevent air pockets. If tamping does not eliminate all air pockets, drill small vent holes through the base surface.
- After the grout has thoroughly hardened, tighten the foundation bolts and connect the piping. **BE CERTAIN PIPING DOES NOT STRAIN PUMP.**
- Check the alignment after the piping is connected and the foundation bolts are tightened.
- Connect the coupling halves.
- When the grout has thoroughly dried, paint the exposed edges to prevent air and moisture from coming in contact with the grout.

PIPING

18. The suction and discharge piping should be arranged for the simplest, most direct layout, to be of sufficient size and be internally free of foreign material. The piping must never be pulled into position by the flange bolts. It must be independently supported and arranged so that expansion and contraction, due to temperature changes, will not cause misalignment. If the installation requires a low noise level of operation, the suction and discharge piping of the system should be connected to the pump suction and discharge flanges with rubber flexible connectors.

19. The suction piping, if not installed properly, is a potential source of faulty operation. To achieve best performance, provide for the following:

- Suction lines, when operating under suction lift, must be kept absolutely free from air leaks.
- The suction pipe, when operating under suction lift, must be at least one pipe diameter larger than the pump suction nozzle. In order to prevent eddies and vortices, the end of the suction pipe must be at least two pipe diameters below the free liquid surface. If a foot valve is used to facilitate priming, the foot valve must have a minimum flow area $1\frac{1}{2}$ times the area of the suction pipe. The suction at all points and should not contain loops or high spots in which air can be trapped.
- A strainer should be installed in the suction line. The screen must be checked and cleaned periodically. The openings in the screen must be smaller than the sphere size allotted for the impeller.
- A pump operating under suction lift should never use a gate or globe valve in the suction line.
- The suction piping size, when operating under suction pressure, may be equal to, but never less than the suction nozzle size.
- Available NPSH must be greater than the NPSH requirement of the pump.
- Piping should be cleaned mechanically and chemically, and flushed prior to installing the pump. A large number of pump packing, mechanical seal and seizure troubles are due to improperly cleaned systems.
- The pump should also be inspected internally for foreign matter that may have entered the pump.



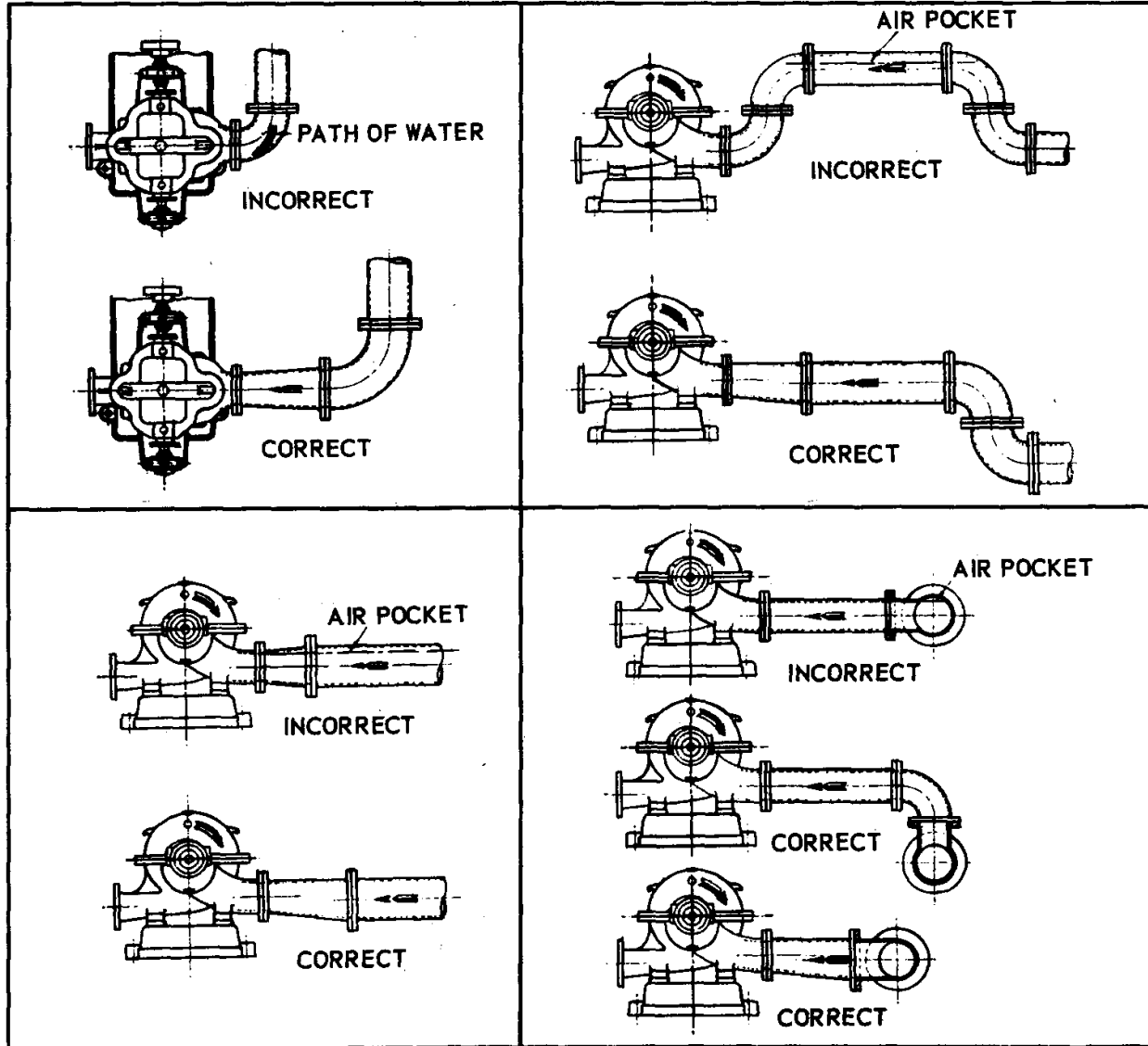

Figure 4 SUCTION PIPING ARRANGEMENTS

DRIVER

20. When the driver of the pumping unit is to be mounted in the field on a base plate furnished by Peerless Pump, the driver bolt holes for some models must be added as follows: Set the base plate with the pump on the foundation and level the unit as in paragraph 11 above. Set the driver on the base plate, and align the coupling halves as described in paragraph 13 above for parallel alignment. Mark the driver bolt holes. Remove the driver and drill and tap the base plate for the driver bolts. Set the driver on the base plate and align completely.

21. Safe and efficient operation of a pumping unit driven by an engine, whether gas, diesel, or gasoline, requires the installation to satisfy the following requirements:

- Be well ventilated in order to keep the ambient temperature as low as possible. Taking 60° F as a datum point, every 10° F rise in temperature reduces the horsepower of the engine by approximately 1%.
- Provide ample air for proper combustion.
- Provide the engine with an efficient exhaust system so that the combustion gasses discharge with a minimum of backpressure.
- Provide for a fuel system of adequate capacity that meets the local codes.



- Provide ample accessibility to service engine.
 - Provide correct rotation of the pump. Engine rotation is determined at the factory. No change of engine rotation can be made in the field.
22. It is recommended that the operator become familiar with the installation and service manual supplied by the engine manufacturer.
23. For electric motor drives, connect power supply to conform to national and local codes. Line voltage and wire capacity must match the ratings stamped on the motor nameplate.
- Only when the coupling halves are disconnected, momentarily energize the motor to check that rotation is in the same direction as the arrow on the pump.
 - If motor is three-phase type, reverse rotation (if required) by inter-changing any two of the three power leads. The rotation of most single-phase motors is fixed by internal wiring and cannot be easily changed.

DOWELING

24. To comply with Hydraulic Institute recommendations, all pumps should be doweled. Pump feet can be drilled for dowels at the factory or in the field. Bases or risers are not drilled at the factory.
25. Doweling the pump accomplishes the following:
- Prevents lateral movement.
 - Eases realignment if the pump is removed from the base.
 - Temporarily holds the pump should the hold down bolts loosen.
26. We recommend installation of straight dowel pins as shown in Figure 5 as follows:
- Check the coupling alignment after the unit has been in operation approximately one week. Correct if necessary (refer to paragraphs 13 and 14 above).
 - Through opposite pump feet, drill through the riser (if used) and into the base (when necessary), holes of the same diameter ($1/64$ inch less than dowel pin) as in the feet to the proper depth for the pins (see Figure 5). Clean out the chips.
 - Ream the holes in the pump feet and base to the proper diameter for the pins (light push fit). Clean out the chips.
 - Install a spare nut (or cap) on the pins to prevent damaging the threads. Insert pins to a depth that leaves sufficient thread to attach nut.
 - Attach nuts and tighten – do not pull dowel.
 - If the pump was not drilled at the factory for dowels, use the following to determine dowel pin diameter. Measure the mounting bolt hole diameter in the pump foot.
 - Dowel diameter = Foot bolt hole diameter minus $3/8$ ".

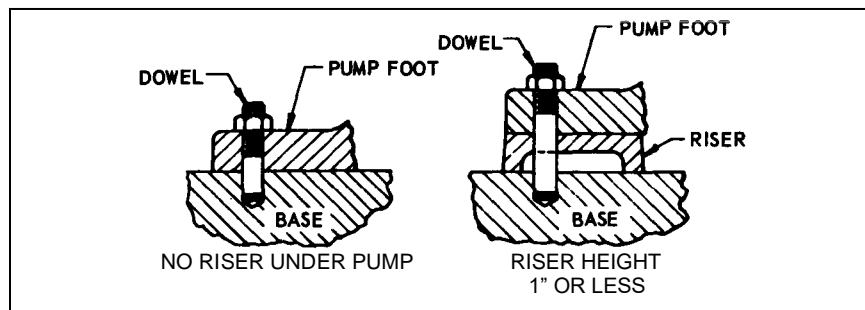
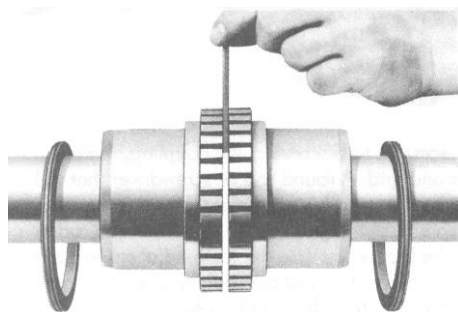

Figure 5 DOWELING METHODS

INSTRUCTIONS

PEERLESS PUMPS WITH FALK STEELFLEX COUPLINGS

(Reprinted with permission of the Falk Corp.)



GAP AND ANGULAR ALIGNMENT

Use a spacer bar equal in thickness to the gap specified in Table 1. Insert bar, as shown, to the same depth at 90° intervals and measure clearance between bar and hub face with feelers. The difference in minimum and maximum measurements must not exceed the ANGULAR limit specified in Table 1.

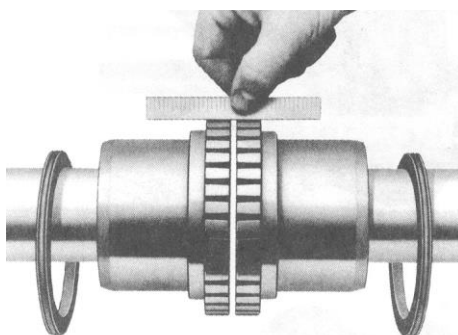

OFFSET ALIGNMENT

Align so that a straight edge rests squarely (or within the limits specified in Table 1) on both hubs as shown and also at 90° intervals. Check with feelers. The clearance must not exceed the OFFSET limit specified in Table 1. Tighten all foundation bolts and repeat Steps 2 and 3. Realign coupling if necessary. NOTE: Use a dial indicator for more accurate alignment.

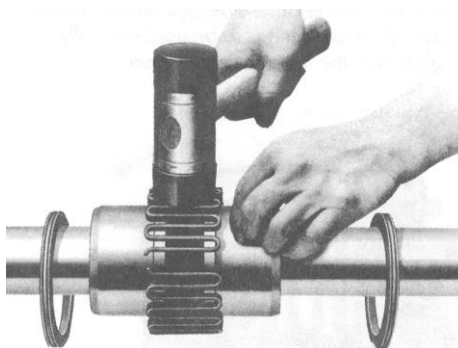

INSERT GRID

Pack gap and grooves with specified lubricant before inserting grid. When grids are furnished in two or more segments, install them so that all cut ends extend in the same direction; this will permit cover installation. Spread the grid slightly to pass it over the coupling teeth and seat with a soft mallet.

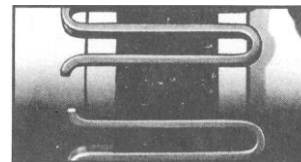

NOTE: COVER MAY BE EITHER OF TWO TYPES AS SHOWN BELOW.

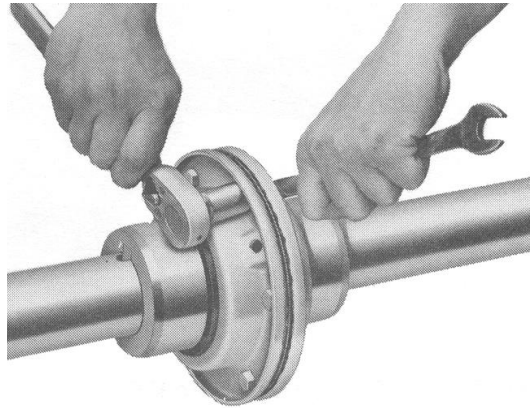
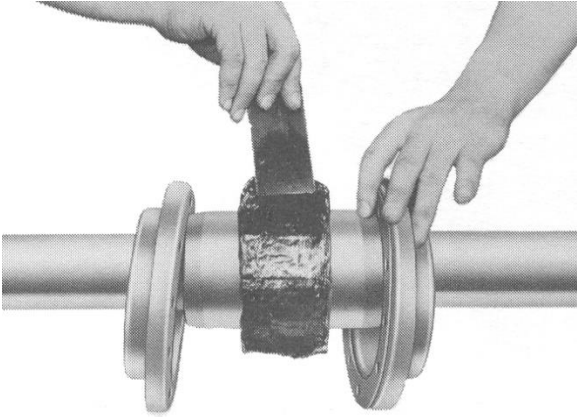

VERTICAL SPLIT STEEL COVER

PACK WITH GREASE AND ASSEMBLE COVERS

Pack the spaces between and around the grid with as much lubricant as possible and wipe off excess flush with top of grid. Make certain lube plugs are removed to ease in cover assembly. Slide cover halves with seals onto hubs and position with lube holes 180 apart (90 apart for Sizes 150 through 170). Line up cover and gasket bolt holes and secure with fasteners; tighten to torque specified in Table 1. CAUTION: Make certain lube plugs are installed before operating.

HORIZONTAL SPLIT ALUMINUM COVER

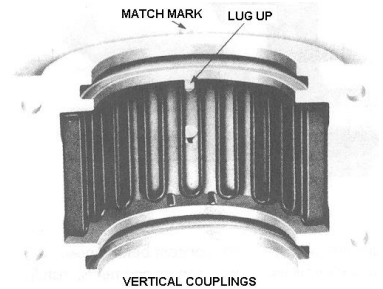
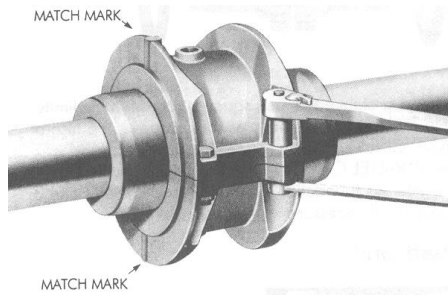
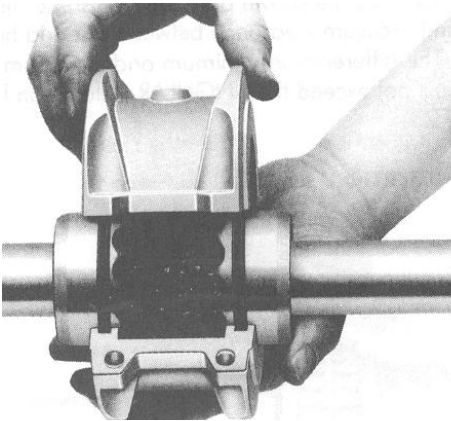

PACK WITH GREASE AND ASSEMBLE COVERS

Pack the spaces between and around the grid with as much lubricant as possible and wipe off excess flush with top of grid. Position seals on hubs to line up with grooves in cover. Position gaskets on flange of lower cover half and assemble covers so that the match marks are on the same side (see above). If shafts are not level (horizontal) or coupling is to be used vertically, assemble cover halves with the lug and match mark UP, or on the high side. Secure cover halves with fasteners and tighten to torque specified in Table 1. (Note that Sizes 20 through 70 have a self-locking feature for the stop nuts.) CAUTION: Make certain lube plugs are installed before operating.

FALK STEELFLEX COUPLINGS, continued

PERIODIC LUBRICATION

Remove both lube plugs and insert lube fitting. Fill with recommended lubricant until an excess appears at the opposite hole. CAUTION: Make certain all plugs have been inserted after lubricating.

COUPLING DISASSEMBLY AND GRID REMOVAL

Whenever it is necessary to disconnect the coupling, remove the cover halves and grid. A round rod or screwdriver that will conveniently fit into the open loop ends of the grid is required. Begin at the open end of the grid section and insert the rod or screwdriver into the loop ends. Use the teeth adjacent to each loop as a fulcrum and pry the grid out radially in even, gradual stages, proceeding alternately from side to side.

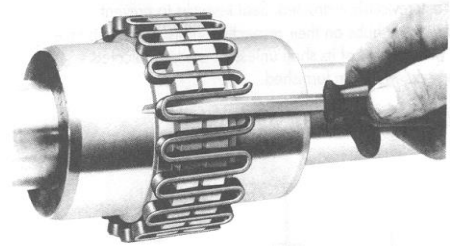

SIZE	Gap	Operating * Alignment Limits		Cover Bolt Torque (lb-in)	Max Speed (RPM)	Lube Wt. (lbs)
		Offset (Max)	Angular (Max)			
		20T	.125			
30T	.125	.005	.005	100	4500	0.06
40T	.125	.005	.005	100	4500	0.12
50T	.125	.005	.005	200	4500	0.12
60T	.125	.010	.010	200	4350	0.19
70T	.125	.010	.010	200	4125	0.19
80T	.125	.010	.010	200	3600	0.38
90T	.125	.012	.012	200	3600	0.56
100T	.188	.012	.012	260	2440	0.94
110T	.188	.012	.012	260	2250	1.10
120T	.250	.012	.012	650	2025	1.60
130T	.250	.012	.012	650	1800	2.00
140T	.250	.015	.015	650	1650	2.50

* Align couplings w ithin "Operating Alignment Limits" specified above. Exceeding these limits reduces coupling life.

WOODS SURE-FLEX COUPLINGS INSTALLATION INSTRUCTIONS TYPE J, S, AND SC

(Reprinted with permission of T. B. Woods Sons Co.)

Sure-Flex flanges (outer metallic parts) and sleeves (inner elastomeric members) come in many sizes and types. All rubber sleeves (EPDM and Neoprene) have the same ratings for a given size and may be used interchangeably. Hytrel sleeves, however, have completely different ratings. **Rubber sleeves must not be substituted for Hytrel, or Hytrel for rubber.** First, determine the size and type of components being used. Remove all components from their boxes, and loosely assemble the coupling on any convenient surface. (Do not attempt to install the wire ring on the two-piece E or N sleeve at this time.)



1. Inspect all coupling components and remove any protective coatings or lubricants from bores, mating surfaces and fasteners. Remove any existing burrs, etc. from the shaft.
2. Slide one coupling flange onto each shaft, using snug fitting keys.
3. Position the flanges on the shafts so that each shaft extends into each flange a minimum length equal to the shaft diameter. Tighten one flange in its final position. Slide the other far enough away to install the sleeve. With a two-piece sleeve, do not move the wire ring to its final position; allow it to hang loosely in the groove adjacent to the teeth, as shown.
4. Slide the loose flange on the shaft until the sleeve is completely seated in the teeth of each flange.

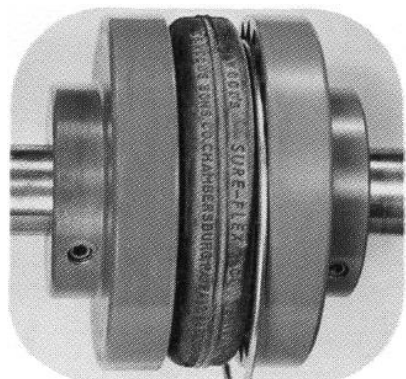

5. Tighten all fasteners to the values given in Table 2.

**TABLE 2 - FASTENER TORQUE VALUES
(ft.-lbs.)**

Coupling Size	TYPE J	TYPE S	TYPE SC	1 Set Screw over Keyway in Hub
	2 Set Screws at 90	2 Set Screws at 90	4 Hex Head Cap Screws Flange to Hub	
3	3	--	--	--
4	3	--	5.5	13
5	7	13	4	13
6	13	13	9	13
7	13	13	9	13
8	23	23	18	23
9	--	23	31	23
10	--	23	50	50
11	--	23	75	50
12	--	50	150	100
13	--	100	150	165
14	--	100	150	165
16	--	100	150	165

Coupling size is marked on flanges

6. Check parallel alignment by placing a straightedge across the two coupling flanges and measuring the maximum off-set at various points around the periphery of the coupling. **DO NOT** rotate the coupling. If the maximum offset exceeds the figure shown under "Parallel" in Table 3, realign the coupling.

Rev 07-2021

7. Check angular alignment with a micrometer or caliper. Measure from the outside of one flange to the outside of the other at intervals around the periphery of the coupling. Determine the maximum and minimum dimensions. DO NOT rotate the coupling. The difference between the maximum and minimum must not exceed the figure given under "Angular" in Table 3. If a correction is necessary, be sure to recheck the parallel alignment. (Note: For maximum life, keep misalignment values as near to zero as possible.)

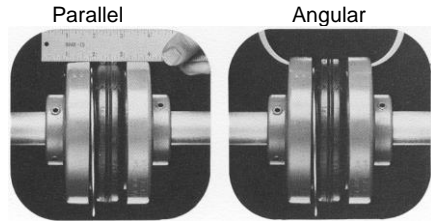

TABLE 3 – MAXIMUM ALLOWABLE MISALIGNMENT
(Dimensions in inches)

SLEEVE SIZE	G DIMENSION	TYPES JES, JNS, E, & N		TYPE H & HS*	
		PARALLEL	ANGULAR	PARALLEL	ANGULAR
3	3/8	.010	.035	—	—
4	5/8	.010	.043	—	—
5	3/4	.015	.056	—	—
6	7/8	.015	.070	.010	.016
7	1	.020	.081	.012	.020
8	1 1/8	.020	.094	.015	.025
9	1 7/16	.025	.109	.017	.028
10	1 5/8	.025	.128	.020	.032
11	1 7/8	.032	.151	.022	.037
12	2 5/16	.032	.175	.025	.042
13	2 11/16	.040	.195	.030	.050
14	3 1/4	.045	.242	.035	.060
16	4 3/4	.062	.330	—	—

NOTE: Values shown above apply if the actual torque transmitted is more than 1/4 the coupling rating. For lesser torque, reduce the above values by 1/2. *Type H sleeves (orange) should not be used as direct replacements for EPDM or Neoprene sleeves (black).

NOTE: Periodically check elastomeric coupling sleeves for any visible evidence of deterioration. If deterioration is apparent, the coupling sleeve must be replaced.

8. If the coupling employs the two-piece sleeve with the wire ring, force the ring into its groove in the center of the sleeve. It may be necessary to pry the ring into position with a blunt screwdriver.
9. Check safety codes and install protective guards or shields as required.

Caution: Coupling sleeves may be thrown from the assembly when subjected to a severe shock load.

SECTION 4 LUBRICATION

COUPLINGS

1. Couplings with elastomeric drive parts do not require lubrication. Most other couplings require some form of lubrication. After completion of installation and alignment, and before operating the unit, lubricate coupling in accordance with manufacturer's specific instructions contained in the pump installation packet or on an instruction tag.

BEARINGS

2. Reasonable care and proper lubrication of pump bearings will result in many years of service. Lubricant is normally grease; oil is optional on some pump types. The lubricant provides a film between the rolling elements and races, giving low friction, and preventing excessive temperature rise and corrosion.

3. The normal life of bearings is terminated only by fatigue. Improper lubrication practices are the primary cause of failure. Good practice includes the following:

- Keep lubricant clean. Provide, and use, a dust tight cover on the storage container.
- Use the oldest lubricant first.
- Clean pump lubricant fittings before re-lubricating with grease.
- Use clean dispensing equipment.
- Use the proper amount of lubricant – too much result in churning, unnecessary power consumption, rapid heating to a high temperature and inadequate lubrication.
- Use the proper lubricant –
 - Grease – Lithium soap base, meeting National Lubricating Grease Institute Grade 2 specifications. This has a safe operating temperature up to 250° F.
 - Oil – see Maintenance and Repair instructions.
 - Some pumps are built with "Lifetime" sealed bearings, requiring no re-lubrication or maintenance. Such pumps are not provided with external lubrication fittings.

OPERATING TEMPERATURE

4. Use of the lubricants and procedures given in this bulletin will allow safe operation at bearing temperatures up to 250°F.

5. A high normal operating temperature is not a sign of bearing failure. Normal temperatures vary with the seasons and environment and may range from 0 to approximately 200° F. A continuous rise (determine as shown in Figure 6) from the **established, normal** operating temperature indicates trouble and probable failure of the bearing. Shut down the pump immediately. Disassemble, clean and inspect the bearing; replace it if required. Refer to Maintenance and Repair instructions.

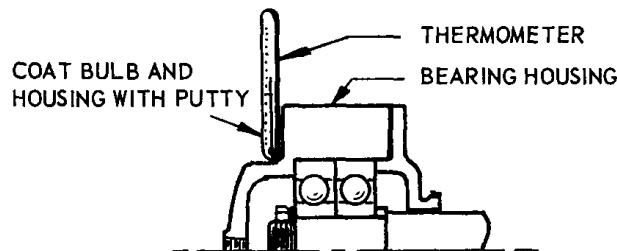

Figure 6 MEASURING BEARING TEMPERATURE

RE-LUBRICATION

Grease

6. Grease that has been in service does not "wear away." It needs replacing only because of contamination by dust, metal particles, moisture, or high temperature breakdown. Re-lubricate bearings as follows (with the pump; shutdown): Pumps have been provided with the initial supply of grease in the bearings.



- Thoroughly clean grease fittings and outside of the bearing housing.
- Inject clean, new grease, forcing out the old through the small opening between the shaft and the bearing housing.
- Start and run the pump for a short time to eject any excess grease.

Oil

7. See Maintenance and Repair instructions.

STUFFING BOX

8. The function of a stuffing box is to limit or eliminate leakage of the pumped fluid and to prevent air from entering along the shaft. Pumps are equipped with packing or mechanical shaft seals. These instructions are intended for pumping units handling water.

Packed Type Seal

9. A packed type stuffing box must correspond to the suction conditions of the installation. The pump is shipped with the packing installed unless otherwise specified by the customer. Check the packing carefully, allowing a slight leakage for lubrication. Never force the packing into a leak-proof position since this will create excessive friction and cause damage to the packing or shaft sleeve. Maximum packing life can be expected when the leakage approximates a minimum of 40-60 drops per minute. A reduction of leakage considerably reduces the life of both the packing and shaft sleeve. If leakage is excessive, tighten the gland bolts evenly, about 1/6 of a turn at a time. Do not be confused if the leakage seems to increase after and adjustment of the packing has been made. The leakage will normally reduce after a period of time as the packing adjusts itself to its new position. It should be kept in mind that it takes time for newly installed packing to "run-in" and that during this initial period, frequent attention and adjustments are necessary. It sometimes takes several days to achieve the desired results. Peerless Pump recommends the use of lantern rings and water seal lines only when suction pressure is less than 30 psig.

10. Replacement packing can be obtained from Peerless Pump or from your local packing supplier.

Mechanical Shaft Seal

11. The mechanical shaft seal is adjusted at the factory and no further adjustment is required except for a short run-in period. Follow the recommendations made by the shaft seal manufacturer to obtain good performance and life.

Special Shaft Seal

12. A separate special instruction is included for any pumps completely describing any special shaft seals. This same instruction will specify any required system piping that is required by the shaft seal arrangement. The pump sectional drawing will completely describe the construction of any special shaft seal.

NOTE

The types of packing listed in Table 1 are for use with water pumps. Pumps handling other liquids may require special types other than those listed.

Table 1 RECOMMENDED STUFFING BOX PACKING ARRANGEMENTS

SUCTION PRESSURE RANGE	PACKING	SHAFT SLEEVE	LEAKAGE RATE
6.0 psiA – 100 psiG	PTFE graphited synthetic latticed braided Crane C1065 or C1070	SAE 40 Bronze or Stainless Steel	50 drops/minute
100 – 175 psiG	Continuous carbon filament yarn, latticed braided packing containing colloidal graphite Crane C1627	SAE 40 Bronze or Stainless Steel	1/3 pint/minute
175 – 250 psiG	Continuous carbon filament yarn, latticed braided packing containing colloidal graphite Crane C1627	Hardened Stainless Steel	1 pint/minute

NOTE

All UL/ULC listed fire pumps will have water seal piping only when suction pressure is less than 30 PSIG.

All FM approved fire pumps will have water seal piping regardless of the suction pressure.

NOTE

See supplemental instruction 4850332 for high-pressure fire pump applications.





SECTION 5 OPERATION

NOTE

Pump cases of steel, cast iron, and especially all iron pumps must be thoroughly flushed prior to initial start-up to avoid contamination of piping systems.

ATTENTION

PRIMING

1. A centrifugal pump must be primed before it can be operated. If run dry, damage can occur to close-clearance rotating parts. Also, if not primed properly, it will not deliver fluid. Prime in one of the following ways:
 - If the system has suction pressure, bleed all air from the pump casing and suction pipe by opening the petcock(s) at the top of the pump. Rotate the shaft a few times if possible to evacuate any air trapped inside the impeller passages.
 - If the system has a suction lift and there is a foot valve in the suction pipe, fill the pump casing and suction pipe with water from an outside source. At the same time, let the trapped air escape through the petcock(s) at the top of the pump.
 - If the system has a suction lift but no foot valve, use a vacuum pump or ejector operated by air, steam, water, engine exhaust, etc., to evacuate the air from the pump case and suction pipe by connecting the ejector to the priming connection on the top of the pump.

STARTING

2. When making an initial start, after installation or major maintenance check the following:
 - Correct installation and rotation of driver.
 - Coupling alignment.
 - Bearing lubrication on pump and driver.
 - Proper lubrication for stuffing boxes. For pumps having mechanical shaft seals, make certain that the liquid temperature, pressure, cooling and lubrication of seal faces all meet the manufacturer's requirements.
 - Gauges (if used) of correct range and in good condition.
 - All foundation, pump, and driver bolts properly tightened. All external fasteners (nuts, bolts, screws) on pump checked against recommended torque values.
 - Suction screens are in place.
 - Recirculation orifice (or device), when installed, must be open during starting. It should be closed during normal operation.
3. Start the pump as follows:
 - When possible, turn the pump shaft by hand to make sure that parts do not bind.
 - Close the discharge valve. (Pumps started with an open valve require more starting torque.)
 - Open the suction valve (if used).
 - Prime the pump.
 - Start the driver. Open the discharge valve as soon as operating speed is reached.
4. Only brief periods of operation during start-up and shutdown are permissible with a closed discharge valve without piping provisions of the release of heat. Prolonged operation at less than 15 to 20% of the pump's rated capacity will cause heating of the fluid pumped, impeller erosion, short life of bearings, and packing or mechanical seals due to stress or vibration. Some pumps may incur shaft damage and wear on stationary parts. Variable RPM drives may be unstable.

**Figure 7 PUMP BYPASS
ARRANGEMENT**



5. During new system tests, check out, early part load system operation, or when prolonged operation at less than about 15% of rated capacity is possible, installation of a pump bypass is recommended as generally shown in Figure 7.

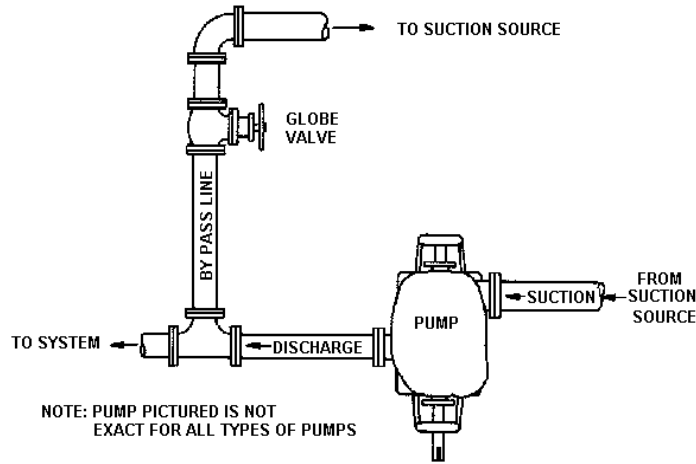

CAUTION

OPERATION OF THE PUMP WITH FLOW ONLY THROUGH THE BYPASS PIPING IS NOT ALLOWABLE.

NOTE

Installation of the bypass piping back to the suction source is recommended; bypass must never be piped closer than 10 pipe diameters to the pump suction flange.

ATTENTION

6. A thermostatic valve (or its automatic equivalent) can be substituted for the manual globe valve with its bulb located in the discharge pipe close to the pump.
7. With the bypass valve open, the pump can be operated above about 20% of its rated capacity and incur little or no erosion or other parts damage. When the pump operates at or near normal capacity, the bypass valve is to be closed. Important: Small volume closed systems may require special cooling arrangements, not just a pump bypass.
8. Operation for prolonged periods at flow rates higher than those given to the pump manufacturer at the time the pump was selected and purchased can cause cavitation, driver overload, noise, and other problems.

CAUTION

Consult with the factory when operating conditions will be different than those for which the pump was purchased.



Important:

ATTENTION

For systems with water over 180° F, use of a recirculation orifice (or device) piped all the way back to the suction supply source is mandatory to avoid flashing (caused by heating of the water) at low flow rates. The reliability of any automatic device must be high and monitors may be installed to warn of malfunction or to cause pump shutdown.

9. After the pump has run a reasonable time, measure the temperature of bearing and stuffing box housings (see Figure 6). The temperature of the stuffing box should approximate that of the pumped liquid. If it is too hot (overheats), the packing is too tight. Stop the pump and repack. See Maintenance and Repair Instructions.
10. Refer to Maintenance and Repair instructions for aid in overcoming trouble in operation.

SHUT DOWN

11. The pump may be stopped with the discharge valve open, as no damage results if water flows back through the casing. Electric motors are free to rotate and may safely run backwards at approximately 1.25 times the rated forward speed. The pump prime may be lost if shut down with an open discharge valve. It may be unwise to leave the discharge valve open on a pump in a manifold system, as short-circuiting may result. Shut down as follows:



Rev 07-2021

- Recirculation orifice (or device), when installed, must be open during shutdown.
 - Close the discharge valve.
 - Shut down the driver. If a motor, press the STOP button or open the switch; if an engine, follow the procedure recommended by the manufacturer in Operating instructions.
 - Turn off all cooling water lines.
12. If water in the lines or pump casing might freeze when shut down, drain completely.





APPENDIX 1 LONG TERM STORAGE

1. Thoroughly drain the pump if it has been in service.
2. If the pump is a packed type pump, remove the stuffing box packing. Discard if the pump has been in service.
3. Spray the interior portion of the pump case and the pump stuffing box with a water-soluble type of rust preventative.
4. Cover the pump suction and discharge flanges with full natural rubber gasket material and blank off these openings with metal blank flanges and a minimum of four full size bolts.
5. Cover the pump stuffing box opening with a non-hygroscopic tape. If a packed type pump, the packing gland may be left on the pump shaft, but must be wired or otherwise securely fastened in position.
6. Coat all exposed machined surfaces with a rust preventative material that is readily removable with a petroleum distillate product.
7. Make sure that all exposed painted surfaces are dry, clean, and free of grease and other contaminants.
8. Cover the pump with a weather resistant cover of waterproof paper or plastic to prohibit the build-up of dirt and dust accumulations.
9. Inspect the pump at regular intervals during the period of storage.
10. Rotate the shaft by hand every 4 to 6 weeks to prevent pitting of the bearings.
11. For the driver and other supplied equipment, follow the long term storage procedures specified in the manuals included with the equipment.
12. To place the unit in, or return the unit to, service, properly remove all protective coatings and install or reinstall packing as described in the repair and maintenance instructions provided with the pump





Rev 07-2021

2005 Dr Martin Luther King Jr Street
Indianapolis, IN 46202





Rev 07-2021

2880549 0919
ECM: 12687209

Trademarks displayed in this material, including but not limited to Peerless Pump and the Peerless Pump logo are registered trademarks owned by Peerless Pump. All rights reserved. © 2019 Peerless Pump. All rights reserved.



Peerless Pump | 2005 Dr. Martin Luther King Jr. Street | Indianapolis, IN 46202
317-925-9661 | www.peerlesspump.com

It is the policy of Peerless Pump to continually seek ways to improve its products and reserve the right to alter documentation without prior notice.

2005 Dr Martin Luther King Jr Street
Indianapolis, IN 46202

