

In-line pumps

Type PV

Instructions

- Installation
- Operation
- Maintenance

Read this entire book

before attempting to install, operate or repair this pump. Properly installed, your Peerless pump will give you satisfactory, dependable service. We urge that you read carefully these step-by-step instructions, to simplify any problems of installation, operation or repair.

Failure to read and comply with installation and operating instructions will void the responsibility of the manufacturer and may also result in bodily injury as well as property damage.

This book is intended to be a permanent part of your pump

installation and should be preserved in a convenient location for ready reference. If these instructions should become soiled obtain a new copy from Peerless Pump. Include pump model and/or serial number with your request.

WARRANTY

New equipment manufactured by Seller is warranted to be free from defects in material and workmanship period of one year from date of shipment; Seller's obligation under this or replacing at its option any part found to its satisfaction to be so defective provided that such part is, factory from which it was shipped, transportation prepaid. This warranty does not cover parts damaged by decomposition from chemical action or wear caused by abrasive materials, nor does it cover damage resulting from misuse, accident, neglect, or from improper operation, maintenance, installation, modification or adjustment. This warranty does not

cover parts repaired outside Seller's factory without prior written approval. Seller makes no warranty as to starting equipment, electrical apparatus or other material not of its manufacture, since the same are usually covered by warranties of the respective manufacturers thereof.

In the event, notwithstanding the terms of this agreement, it is determined by a court of competent jurisdiction that an express warranty has been given by Seller to Purchaser with respect to the head, capacity or other like performance characteristics of said equipment, Sellers liability for

breach of the same shall be limited to accepting return of such equipment F.O.B. plant of manufacture, refunding any amount paid thereon Purchaser (less depreciation at the rate of 15% per year if Purchaser has used equipment for more than thirty (30) days) and canceling any balance still owing on the equipment.

THIS WARRANTY IS EXPRESSLY IN LIEU OF ANY OTHER WARRANTIES, EXPRESSED OR IMPLIED, AND SELLER SPECIFICALLY DISCLAIMS ANY IMPLIED WARRANTY OF MERCHANTABILITY OR FITNESS FOR A PARTICULAR PURPOSE.



Peerless Pump Company

2897336

Rev. 3/82

IMPORTANT SAFETY PRECAUTIONS

Pump parts, and the tools and rigging equipment used in installing pumps, are heavy and may easily cause personal injury if dropped or carelessly handled. The normal precautions and safety rules associated with the erection of heavy machinery, in regard to manual lifting, use of power equipment, and handling of tools, must be observed in the installation of this pump.

Petroleum-base cleaning solvents are flammable. Smoking by personnel in the vicinity of these solvents is

extremely hazardous and must not be permitted.

Do not work under a heavy suspended object unless there is a positive support under it or stop its fall in event of sling or hoist failure. Disregard of this warning could result in grave personal injury.

Before opening the conduit box of an electric motor, be certain that the current to the motor is shut off. An electrical shock from contact with live motor leads can be fatal.

Before attempting repairs to pump open the disconnect switch to electric motor. This prevents accidental running of pump motor. Starting motor during pump repair activities could damage pump and may cause personal injury.

Because cap screws have a tendency to loosen on shipment retighten all cap screws to casing and to motor adaptor before installing pump. Refer to reassembly instructions paragraph 7 for torque values.

WARNING

The pumps described by this manual must not be installed in any manner except as specified herein, and must not be operated at a speed or a flow capacity different than those specified at the time of original construction. If

you are unsure of originally specified speed or flow capacity, or any changes to speed or flow capacity are being considered, do not proceed without consulting the Peerless Pump factory or serious equipment damage

and failure may result. The pump must be operated within the limitations describe by the pressure-temperature table reproduced below.

Maximum Working Pressure	Pumped Liquid Temperature
175 PSIG @	20° - 150° F
165 PSIG @	200° F maximum allowable for iron fitted construction
150 PSIG @	250° F maximum allowable for bronze fitted construction

These pumps must not be used to pump any fluid other than that specified for the order. Liquids to be pumped must be non-corrosive and non-abrasive or damage can occur to the pump. The liquid pumped by a mechanical seal version of a pump with bronze fitted construction must

not contain hydrocarbons or the mechanical seal will be damaged and pump failure will result. Note: Mechanical seals which will not be damaged by the presence of hydrocarbons are available and may be obtained from the factory. Such seals are standard in mechanical seal

versions in mechanical seal versions of pumps with iron fitted construction. Violation of this warning will void the warranty and may result in serious property damage or grave personal injury.

INTRODUCTION

UPON RECEIPT OF PUMP EQUIPMENT-

Check carefully to see that all of the equipment has been received. Report immediately any shortages or damages to the transportation company handling the shipment, noting the extent of the damage or shortage on the freight bill and bill of lading.

Do not leave the unit exposed to

weather or construction hazards. The pump may become mechanically damaged. This pup is a well designed and carefully manufactured unit. It should be given the same attention accorded to any precision machine.

The satisfactory operation of a pump depends to a large extent upon proper installation. These instructions cannot answer every question that may arise

as each installation will be different. The installer and the operator of this equipment must use good judgment to adapt these procedures to his installation.

NOTE: Additional information on normal installation and operation procedures may be obtained by reference to Hydraulic Institute Standards Manual.

PUMP TYPES

Type PV In-line pumps are furnished with mechanical seal only. Either bronze fitted or iron fitted construction may be furnished in accord with original specification.

INSTALLATION

WARNING

Do not work under a heavy suspended object unless there is a positive support under it to stop its fall in event of sling or hoist failure. Disregard of this warning could result in grave personal injury.

LOCATION: The pump should be installed in a clean, well-drained and ventilated location, and be accessible for inspection and proper care. Ample room should be provided for installation and removal.

FLOOR MOUNTING: Type PV In-line pumps have been designed to be supported by the piping in the system with the motor above the pump. An optional cast iron base is available for floor mounting the pump.

PIPING: The suction and discharge piping should not be smaller than the inlet or outlet connections of the pump. Be sure the suction connections are tight because air leakage can cause a reduction in pump capacity or loss of prime. For service convenience valves should be provided in suction and discharge piping. See Note 2 in Pump Disassembly.

CAUTION

Make certain that the pump is free from piping strains, which may cause misalignment, resulting in a possible

binding of the rotating element. Avoid springing the piping into line and use caution when tightening the connections. Suction and discharge piping must have adequate support for itself and the pump it supports. The lifting lugs on the motor must not be used to support the installation. Failure to adhere to these precautions can result in equipment damage and malfunction.

WIRING AND CONTROLS: For electric motor drives connect power supply to conform with national and local codes. Line voltage and wire capacity must match the ratings stamped on the motor nameplate. **DO NOT USE ANY OTHER VOLTAGE.**

PUMP ROTATION: Momentarily operate the motor to check that the pump shaft rotates clockwise as shown by the arrow on the pump casing. Do not allow motor to run in reverse (opposite to arrow) direction for any length of time.

CAUTION

Prime pump before starting motor or damage can occur to internal pump parts.

PRIMING: A centrifugal pump must be primed before it can be operated. If

run dry, damage can occur to close-clearance rotating parts and will destroy mechanical seal faces. Also, if not primed properly, it will not deliver fluid. Prime in one of the following ways:

a. If the system has suction pressure, bleed all air from the pump casing and suction pipe by opening the pipe plug provided at top of the discharge nozzle. Rotate the shaft a few times if possible to evacuate any air trapped inside the impeller passages.

b. If the system has a suction lift and there is a foot valve in the suction pipe, fill the pump casing and suction pipe with water from an outside source. At the same time, let the trapped air escape through the pipe plug at the top of the discharge nozzle.

c. If the system has a suction lift but no foot valve, use a vacuum pump or ejector operated by air, steam, water, engine exhaust, etc., to evacuate the air from the pump case and suction pipe by connecting the ejector to the priming connection on the top of the discharge nozzle.

Note: The pump is furnished with a by-pass line from the pump suction to the stuffing box, which purges the air from the seal cavity.

OPERATION

BEFORE STARTING THE PUMP:

1. Never operate or spin the pump unless it is fully primed. (See "Priming".)
2. Turn the shaft by hand to see that it rotates freely.
3. Check that the voltage and frequency on the motor nameplate match the current supply.
4. Be sure the motor is wired for correct voltage.
5. Check that all thermal overload relays are of the proper size and "set" for operation.
6. Be sure the valve in the suction

line is open. The discharge valve should be closed.

7. Review remainder of these instructions.

AFTER STARTING THE PUMP:

1. Check the pump rotation with the direction of the arrow on the pump casing. If necessary, change direction.
2. Check the pump for evidence of rubbing or binding which may have been caused by piping strains.

CAUTION

Overheating will result if pump is operated

against a closed valve for more than a few minutes. If closed valve operation is required, install a by-pass line or a small relief valve discharging back to the pump suction. Suction valve should not be used to regulate flow of the pump. Suction valve should be wide open during pump operation and flow is to be regulated by the discharge valve. Failure to adhere to these precautions can result in equipment damage and malfunction.

3. Slowly open the discharge valve.
4. See that all pipe connections are tight.

LOCATING TROUBLE

IF PUMP AND MOTOR

FAIL TO START:

1. Check for blown fuses or a tripped thermal overload relay.
2. Shaft may be stuck or binding due to rubbing of clogged impeller or other mechanical defect.
3. Starter contacts may be corroded, shorted, or terminal connections may be broken somewhere in the circuit.
4. The wiring hookup or voltage provided may be incorrect or switches may not be "set" for operation.

IF INSUFFICIENT OR NO WATER IS DELIVERED:

1. Pump may not be primed. (See "Priming").

2. The speed may be too slow. Check for low voltage.
3. The required discharge pressure may be higher than anticipated.
4. Suction pressure may be lower than anticipated.
5. The impeller may be clogged or damaged.
6. Wrong rotation. Check direction of shaft rotation with arrow on the pump casing.
7. The suction or discharge lines may be clogged or valves in lines may not be fully open.

IF PUMP LOSES PRIME:

1. The suction line may be leaking.
2. The suction pressure may be too low.

3. The pumped liquid may contain air or gas.

IF PUMP VIBRATES OR IS NOISY:

1. The foundation may be insufficient or not secure.
2. The impeller may be partially clogged causing an unbalanced condition.
3. Mechanical defects may be evident, such as a bent shaft, rotating element binding or worn bearings.
4. Suction or discharge pipes may not be anchored sufficiently.
5. The pump may be vapor bound –not fully primed. (See "Priming").
6. Insufficient net positive suction head available; cavitation.

MAINTENANCE

To insure the best operation of the pump, make a systematic and periodic inspection to check the following:

1. See that the driver is up to speed. Check driver manufacturer's instructions for periodic maintenance.
2. See that the electrical control equipment is clean and contacts are in good condition.

3. Check operation of the pump. See that it runs smoothly and is reasonably quiet.

CAUTION Where the pump is installed in an unheated location, precaution must be taken to protect the pump and pipe lines from freezing. If the unit is to remain idle for long periods during cold

during cold weather, the pump must be drained by removing the drain plug in the bottom of the casing (1). Re-prime pump when reused.

LUBRICATION: No pump lubrication is required. Adhere to the motor manufacturer's recommendations for lubricating the motor.

MECHANICAL SEAL

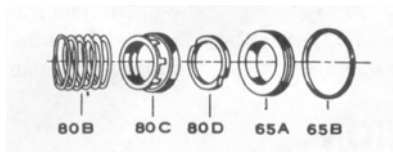

80B Spring
80C Seal Bellows Assy

80D Sealing Washer
65A Floating Seat
65B Seat Ring

PUMP DISASSEMBLY

WARNING Always take adequate precaution to prevent accidental running of pump motor, before starting maintenance on pump. Starting motor during pump removal could damage pump and may cause personal injury.

1. Open the disconnect switch to cut off power to the motor. Temporarily tie switch open and attach note: DO NOT CLOSE SWITCH – PUMP REPAIR IN PROCESS.

2. Close valves in suction and discharge lines.

WARNING Before opening conduit box of electric motor be certain that the current to the motor is shut off. An electrical shock from contact with live motor leads can be fatal.

3. Disconnect the motor leads and carefully mark them so they can be reconnected in the exact same order.

4. Remove plug from bottom of casing (1, Figure 1) and drain casing.
5. Disconnect suction and discharge lines.

NOTE: The pump need not be disconnected from suction and discharge piping for disassembly.

6. If pump is base mounted, remove the base hold-down bolts and move pump to bench for disassembly.

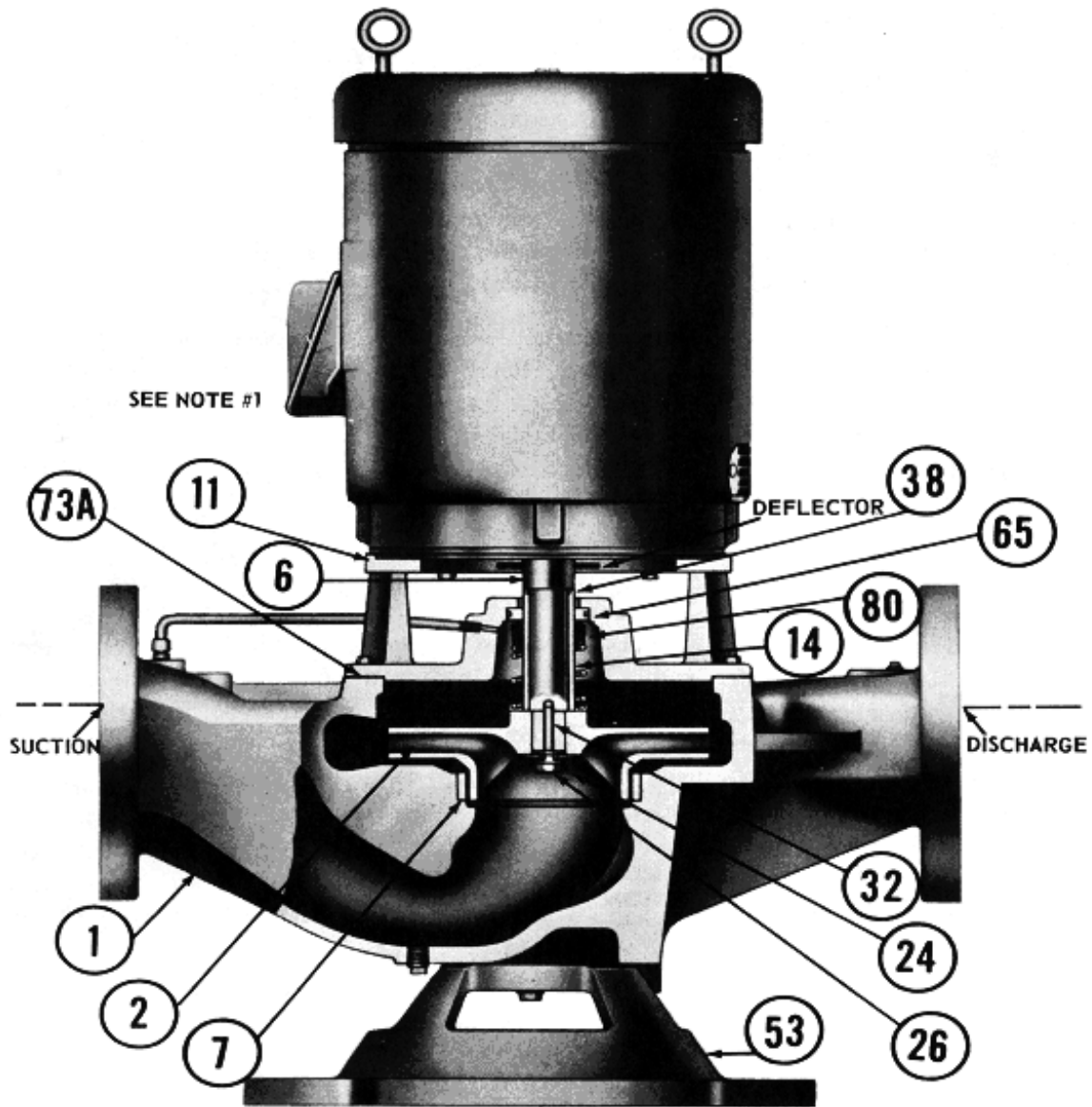

NOTE 1. Conduit box located 45 degrees clockwise from suction flange as viewed from motor end (motor may be rotated in 90 degrees increments).

STANDARD CONSTRUCTION

OPTIONAL

- 1 Casing – Cast Iron
- 2 Impeller – Bronze
- 6 Shaft – Steel
- 7 Casing Ring – Bronze
- 11 Adapter – Cast Iron
- 14 Shaft Sleeve – Bronze
- 24 Impeller Washer – Stainless Steel

- 26 Impeller Lock Screw – Stainless Steel
- 32 Impeller Key – Steel
- 38 Shaft Sleeve Gasket – Neoprene
- 65 Mechanical Seal – Stationary Element
- 73A Casing Gasket – Fiber
- 80 Mechanical Seal – Rotating Element

- 53 Base – Cast Iron

Figure 1. PV In-line Pumps

Disassemble pump in the following manner:

1. Remove any seal piping (tubing) between pump discharge and stuffing box of adapter (Item 11, Figure 1).
2. Remove cap screws holding adapter (11) to casing (1). Before removing rotating assembly, scribe assembly marks on casing, motor, and adapter flanges so that unit can be reassembled in same orientation. Then remove complete rotating assembly by lifting motor from casing.
3. Insert a rod of suitable diameter into a passage of impeller (2) and hold

while loosening impeller lockscrew (26). Remove screw and impeller washer (24A).

4. Slide impeller from end of shaft (6) and remove impeller key (32). If it is necessary to pry the impeller off, use a gear or wheel puller so that force is exerted on the motor shaft and not the motor bearings. Pry evenly on opposite sides of impeller where bending or denting of impeller shrouds will not occur.
5. Very carefully remove seal parts (80A thru 80D). Be particularly careful not to scratch or damage lapped surface of sealing washer (80D). Store seal parts in suitable container: lapped

container; lapped surface of sealing washer must be up and covered.

6. Remove screws and slide adapter (11) off from shaft. Use care not to scratch shaft sleeve (14).
7. Carefully push floating seat (65A) from adapter, avoiding scratching or other damage to lapped surface. Use narrow, flat screwdriver to lift and work O-ring (65B) from seat. Store seat with remaining mechanical seal parts with lapped surface up and covered.
8. Slide shaft sleeve (14), shaft sleeve gasket (38) and deflector from shaft.
9. Remove casing ring (7) from casing only if damaged or worn to excess (refer to Repair).

CLEANING

WARNING Petroleum – base cleaning solvents are flammable. Smoking or open flames in the vicinity of these solvents is extremely hazardous and must not be permitted. Disregard of this warning could result in grave personal injury.

Clean all metal parts with a solvent.

Use a bristle brush (not metal or wire) to remove tightly adhering deposits. A fiber scraper may be used to remove the gasket and shellac from casing flanges. Blow dry with clean dry compressed air.

Caution Never use hydrocarbon liquids (oil or solvent)

to clean mechanical seal parts. Use of oil or solvent will deteriorate material used for manufacture of the seal.

Clean seal parts using a mild soap solution. Rub only with finger to remove dirt. Rinse with clear water and dry with mild air stream. Use care not to damage or scratch lapped surfaces.

INSPECTION

Visually inspect and replace parts that are damaged and affecting the serviceability or sealing. Emphasize inspection of mating parts having relative motion – casing rings, for example. Perform detailed inspection as follows:

1. Check O-rings, gaskets, and seals

for shrinkage, cracks, nicks or tears.

2. Examine impeller passages for cracks, dents, gouges or embedded material.
3. Inspect shaft sleeves (14) for excessive wear. Replace sleeves that are worn. Replace gasket.

4. Inspect lapped surfaces of sealing washer and floating seat for chipping, gouges, nicks, scratches or other damage. These surfaces must be free from any defect. If lapped surfaces are damaged, replace the entire seal.

REPAIR

When ordering repair parts give the complete pump nameplate data (nameplate on the pump casing) plus the name and item number of the part shown on sectional view.

Remove burrs, nicks, and scratches from non-critical areas with a fine stone or crocus cloth.

1. Impeller and Casing Ring. If the pump capacity falls off due to wear on the impeller and casing ring, repair is made by replacing the casing ring. The inside diameter of the casing ring should be 0.008" to 0.012" larger than the impeller skirt diameter.

2. Normally, when the pump is completely disassembled, all gaskets, O-rings and seals should be replaced at reassembly. If the O-ring for the floating seat of the mechanical seal is not damaged, it may be reused with the other, satisfactory seal parts.

REASSEMBLY

WARNING The replacement of electric motor must be of the same voltage, RPM and frame number as original motor. If re-placement motor is of higher RPM pump will develop excessive pressure and horsepower causing pump and equipment damage and personal injury.

Reassemble pump in the following manner:

1. Install deflector shaft sleeve gasket (38) and shaft sleeve (14) on shaft. Be sure gasket is completely contained by sleeve and that sleeve bottoms on shaft shoulder. Align sleeve slot with key slot of shaft.

CAUTION Use care not to mar scratch the lapped surfaces of floating seat and sealing washer when installing mechanical seal. Damage to these surfaces will result in leakage and will require replacement of the entire seal.

2. For the mechanical seal pump, lubricate the O-ring (65B), groove in floating seat (65A) and seat cavity in adapter (71) with any of MOLYKOTE® 3% detergent solution, mild soap solution, glycerine, ethylene glycol or silicone grease, DC No. 55.

3. Install floating seat in the adapter with lapped surface facing away from adapter shoulder. Apply lubricant (step 2 above) to entire surface or shaft sleeve and carefully install adapter. Use care not to cock or scrape floating seat on sleeve. Seat adapter (71) against motor, tapping very lightly with plastic hammer, then install screws and tighten uniformly. Rotate shaft by hand to check that there is no binding or hang-up.

4. In the same manner as in step 3, lubricate the entire surface of shaft sleeve and the bores of sealing (80D) and spring bellows assembly (80C).

5. Install impeller key (32) in shaft keyway. Make sure that key enters slot in shaft sleeve. Align impeller (2) with key and install on shaft. Tap impeller hub lightly with plastic hammer to seat against shaft sleeve. Guide spring to seat on the shoulder as impeller is installed. Be sure spring is correctly seated against bellows assembly.

6. Install impeller washer (24A) and impeller lock screw (26). Restrain impeller with rod inserted in one passage and securely tighten screw. Rotate shaft by hand to check for free movement.

7. Lightly coat both sides of casing gasket (73A) with a non-hardening sealing compound, such as grease and graphite. Position on adapter making sure that holes are aligned. Carefully lower complete pump rotating assembly into casing, keeping the impeller properly aligned to prevent binding and possible damage. Make sure the assembly marks match to insure that proper orientation of the unit is maintained. Install screws and tighten uniformly in a star pattern. The cap screws are SAE Grade 5 and are to be tightened to the following minimum torque values for dry threads.

Size	Torque
3/8	30 ft - lbs
7/16	50 ft - lbs
1/2	75 ft - lbs
5/8	155 ft - lbs

8. Install seal piping between pump suction and stuffing box adapter.

9. Re-connect motor wiring and follow instruction – Pump Operation.

NOTICE:

Materials of construction, specifications, dimensions, design features, and application information, where shown in this bulletin, are subject to change and/or modification without notice by Peerless Pump at their option.



Peerless Pump Company

P.O. Box 7026 – Indianapolis, IN 46207-7026
Phone: (317) 925-9661 – Fax: (317) 924-7388