



2022

Sewage Ejector Flush Kleen Series P Type F and FI

INSTALLATION, OPERATION, MAINTANENCE, AND
REPAIR



Read this entire book

before attempting to install, operate or repair this unit. Properly installed, your Peerless Pump FLUSH-KLEEN® will give you satisfactory, dependable service. We urge that you read carefully these step-by-step instructions, to simplify any problems of installation, operation or repair.

Failure to read and comply with installation and operating instructions will void the responsibility of the

manufacturer and may also result in bodily injury as well as property damage.

This book is intended to be a permanent part of your pump installation and should be preserved in a convenient location for ready reference. If these instructions should become soiled obtain a new copy from Peerless Pump. Include pump model and/or serial number with your request.

WARRANTY

New equipment manufactured by Seller is warranted to be free from defects in material and workmanship under normal use and service for a period of one year from date of shipment; Seller's obligation under this warranty being limited to repairing or replacing at its option any part found to its satisfaction to be so defective provided that such part is, upon request, returned to Seller's factory from which it was shipped, transportation prepaid. This warranty does not cover parts damaged by decomposition from chemical action or wear caused by abrasive materials, nor does it cover damage resulting from misuse, accident, neglect, or from improper operation, maintenance, installation, modification or adjustment. This warranty does not cover parts repaired outside Seller's factory without prior written approval. Seller makes no warranty as to starting equipment, electrical apparatus or other material not of its manufacture, since the same are usually covered by warranties of the respective manufacturers thereof.

In the event, notwithstanding the terms of this agreement, it is determined by a court of competent jurisdiction that an express warranty has been given by Seller to Purchaser with respect to the head, capacity or other like performance characteristics of said equipment, Seller's liability for breach of the same shall be limited to accepting return of such equipment F.O.B. plant of manufacture, refunding any amount paid thereon by Purchaser (less depreciation at the rate of 15% per year if Purchaser has used equipment for more than thirty (30) days) and canceling any balance still owing on the equipment.

THIS WARRANTY IS EXPRESSLY IN LIEU OF ANY OTHER WARRANTIES, EXPRESSED OR IMPLIED, AND SELLER SPECIFICALLY DISCLAIMS ANY IMPLIED WARRANTY OF MERCHANTABILITY OR FITNESS FOR A PARTICULAR PURPOSE.



IMPORTANT SAFETY PRECAUTIONS

Pump parts, and the tools and rigging equipment used in installing pumps, are heavy and may easily cause personal injury if dropped or carelessly handled. The normal precautions and safety rules associated with the erection of heavy machinery, in regard to manual lifting, use of power equipment, and handling of tools, must be observed in this installation.

Petroleum-base cleaning solvents are flammable. Open flame or smoking by personnel in the vicinity of these solvents is extremely hazardous and must not be permitted.

Do not work under a heavy suspended object unless there is a positive support under it to stop its fall in event of sling or hoist failure. Disregard of this warning could result in grave personal injury.

Check valve tee assembly is heavy; a hoist, or other lifting device of proper capacity should be used to handle this assembly. Disregard of this warning could result in grave personal injury.

Before opening the conduit box of an electric motor, be certain that the current to the motor is shut off.

An electrical shock from contact with live motor leads can be fatal.

Before attempting any repairs open the disconnect switch to electric motor. This prevents accidental running of pump motor. Starting motor during repair activities could damage pump and may cause personal injury.

Do not use motor electrical cable to lift or lower submersible sewage pump. Use the pump lugs provided to attach sling or cable for lifting and lowering pump into basin. Electrical cable strains may cause equipment malfunction, damage, and personal injury or death.

Pump unit will be unstable once the discharge pipe has been removed as the weight of the strainer casing and check valve tee will cause the unit to be off balance. Provide a support for the unit to prevent it from tipping over. Disregard of this warning could result in grave personal injury.

Tie the disconnect switch open or remove fuses from lines before attempting to remove pump unit from the basin. Attach a card: "Do Not Close Switch. Pump Repair in Process." Disregard of this warning could result in a fatal electrical shock.

OPERATION

FLUSH-KLEEN® pumps are usually installed in duplex sets. It is recommended to use an automatic alternator to transfer operation from one pump to the other pump. Only one pump functions at a time, except during unusual flow conditions when both units may operate. While one pump is running, sewage flows into the wet basin through the idle pump. If the flow is too great to pass through one pump, the excess water enters the wet basin through the overflow strainer. Coarse matter is stopped by the

strainer in the discharge line of the idle pump, and only water passes into the wet basin. Coarse matter never enters the pump or reaches the basin. When the idle pump starts, the accumulated solid matter in the strainer of discharge line is flushed out with discharge water from the basin and is carried into the sewer. The check valve in the check valve tee assembly is forced shut when the pump starts, thus preventing pump from discharging back through the inlet line.

INSTALLATION

WARNING Pump parts, and the tools and rigging equipment used in installing pumps, are heavy and may easily cause personal injury if dropped or carelessly handled. The normal precautions and safety rules associated with the erection of heavy machinery, in regard to manual lifting, use of power equipment, and handling of tools must be observed in this installation.

Layout drawings are furnished with FLUSH-KLEEN pump equipment in accordance with detailed information and dimensions provided by the customer. Installations should be made only from certified installation prints. It is important that concrete structure, wall opening, etc., be constructed to plans. The component parts for the FLUSH-KLEEN system have been machined to fit that installation per detailed information previously provided. FLUSH-KLEEN units are usually used with duplex pumps.

To obtain a satisfactory piping system, note the following general piping recommendations:

- (a) Adhere accurately to all installation print dimensions.
- (b) Where running pipe through concrete wall, the best practice is to leave generous, grooved, square holes. Employ standard pipes.

NOTE: Grout the pipes in only after pump units are set and all final connections have been made.

- (c) Make pipe connections to pumps so that there are no strains upon the unit. Flexible connections are used on inlet filler pipe (23) so that if dimensions and instructions are followed little difficulty should be encountered in pipe installation. (d) When raw sewage is handled the basin should be vented to the atmosphere.
- (e) Install inlet hub assembly to provide gravity flow into the check valve tee assemblies.

INSTALLATION EQUIPMENT: The equipment necessary for installation will vary with the size of the pump and the type of installation. The following list of tools is merely a guide for the installer:

1. **Hoist:** One that can be located overhead to move the major components. The hoist must have lifting capacity to handle the pump, motor and any other items that may be attached. Peerless Pump will tell you the weight of pump and motor supplied on the original order, if desired. Please reference your request with pump serial number and model number.

2. **Standard Tools:** A set of standard millwright tools including open end and socket wrenches; pipe wrenches; a mechanic's level; a mill file; a wire brush and clean rags.
3. **Wire Rope Slings:** These slings will be necessary for lifting the pump.

WARNING Do not work under a heavy suspended object unless there is a positive support under it to stop its fall in event of sling or hoist failure. Disregard of this warning could result in grave personal injury.

INSTALLING INLET HUB ASSEMBLY

A. Cast Iron, Steel and Fiberglass Basins.

Note: Inlet hubs are furnished as a standard to fit a square basin. If the inlet hub is to be used with a round basin, an adapter is required. Inlet hub must be mounted in basin by installer prior to setting of basin. Secure the inlet hub assembly (18) and gasket (20) to the basin with screws provided. Locate the inlet hub assembly to provide gravity flow into the check valve tee assemblies (11). See basin drilling detail page 11 for securing inlet hub assembly to the basin if the basin has not been predrilled. Use lead and oakum to calk sewage inlet pipe into the inlet hub assembly.

B. Concrete Basins.

Where basins are constructed of concrete an adapter flange is required. This flange screws onto the 6" sewage inlet pipe with 6" NPT threads. Customer is required to thread inlet pipe. Allow the sewage inlet pipe to extend beyond basin wall.

Screw the adapter flange onto the sewage inlet pipe. The position of holes are to be on center. Bolt inlet hub and gasket on flange. (See page 7). The sewage inlet pipe requires grouting. Grout in only after the pump units are set and all connections have been made.

WARNING Do not work under a heavy suspended object unless there is a positive support under it to stop its fall in event of sling or hoist failure. Disregard of this warning could result in grave personal injury.

INSTALLING PUMPS AND FLUSH KLEEN FITTINGS

VCS Pumps:

1. Set the basin cover over the basin. Pump openings are usually located at the far side of the basin away from the inlet hub assembly. The cover must be accurately set so that the pumps are suspended exactly in their proper positions; therefore, do not permanently fix the basin cover in place until pumps are installed and connected.

2. Set the pumps, carefully lowering them into the basin cover opening until pump floor plates rest on the basin cover. Take care not to damage lubrication lines or bump the pump casings. Note: Pumps are right and left hand; refer to page 11 for location.

3. Remove packing plates from inlet hub assembly and check valve tee assembly, lubricate a-ring and slide these plates onto inlet pipe with a twisting downward motion. Bolt inlet pipe and plates back in position.

4. Tighten up all connections, fasten down the basin cover. Complete the discharge piping, fasten down floor plates and grout in wall pipe if applicable.

5. For additional installation information see VCS Bulletin 4847583.

UW Pumps: (Refer to page 10 for Item Numbers.)

WARNING Do not use motor electrical cable to lower submersible sewage pump. Use the pump lugs provided to attach sling or cable for lifting and lowering pump into basin. Electrical cable strains may cause equipment malfunction, damage, and personal injury or death.

1. Set the pumps, carefully lowering them into the basin until the pumps rest on the bottom of basin. Set basin cover in position. Do not permanently fix in place.

2. Slide strainer assembly (9) thru strainer housing (5). Bolt strainer plate (3) and strainer plate gasket (4) to strainer housing with two 5/8 x 11 x 1 inch long cap screws (2).

3. From below the basin add the pump discharge flange gasket (25) and bolt the assembly from note 2 to the pump discharge flange with two 5/8-11 x 1-3/4 long cap screws (1). Slip the a-ring (6) into groove provided on the strainer housing. Lubricate the a-ring for ease of assembly. Place the strainer casing (7) into assembly, and with a twisting downward motion, press the strainer casing into position.

4. Place the check valve tee assembly (11) and gasket (10) on top of the strainer casing assembly and bolt together. Check valve tees are left and right hand. Refer to page 11 for their proper positions.

WARNING Pump unit will be unstable once the check valve tee assembly has been bolted to strainer casing as the unit will be off balance. Provide a support for the unit to prevent from tipping over. Disregard of this warning could result in grave personal injury.

5. Measure the distance between the top of basin cover and check valve tee assembly to determine the length of discharge pipe required. Cut pipes to required length and thread on both ends. Use 4" 10 steel pipe. Screw the companion flange (8) onto the discharge pipe. Slide the pipe through the opening provided in the basin cover and with gasket provided (15) bolt to check valve tee assembly. Install discharge fitting on top of basin cover including gasket.

6. Remove packing plate from inlet hub assembly and check valve tee assembly. Lubricate a-ring and slide these plates onto the inlet pipe with a twisting downward motion. Bolt inlet pipe and plates back in position.

7. Tighten up all connections, fasten down the basin cover and grout in all wall pipes if applicable.

8. For additional installation information see UW Bulletin 2899213.

MAINTENANCE

Clogging of FLUSH-KLEEN unit is practically impossible under normal circumstances. However, to insure maximum efficiency and to prevent tuberculation of inner pipe surfaces, inspection of strainers, inlet hub and check valve at two year intervals (during a low flow period) is recommended. There are hand hole covers located on the

check valve tee assemblies which can be removed for inspection of check valve disc, or for cleaning. The individual shutoff valve to each pump on the inlet hub permits isolation of either pump for inspection while the other pump remains in operation.

REPAIRS

WARNING Petroleum-base cleaning solvents are flammable. Smoking or open flames in the vicinity of these solvents is extremely hazardous and must not be permitted. Disregard of this warning could result in grave personal injury.

Pump disassembly, repair and reassembly are covered by specific bulletins for models supplied. The following applies to FLUSH-KLEEN components other than pumps.

1. Cleaning. Clean all metal parts with a solvent. Use a bristle brush to remove tightly adhering deposits.
2. Inspection. Visually inspect parts for damage affecting serviceability or sealing.
3. Remove burrs, nicks or scratches with a file of fine stone.

REMOVAL

Remove FLUSH-KLEEN unit in the following manner.

1. Reduce system flow to a minimum or no flow condition.
2. It is recommended to bail, drain or pump out the basin to improve working conditions.

WARNING Tie the disconnect switch open or remove fuses from lines before attempting to remove pump unit from the basin. Attach a card: "Do Not Close Switch. Pump Repair In Process." Disregard of this warning could result in a fatal electrical shock.

3. Open the disconnect switch at power supply. Tie switch open and attach a card to prevent closing accidentally.

4. Place the shutoff valve to close position on inlet hub which leads to the pump that is being removed. To close valve loosen gland bolt and lift valve until gland bolt disengages from slot. Swing gland bolt back toward inlet hub and slide valve to its downward position.

WARNING Do not work under a heavy suspended object unless there is a positive support under it to stop its fall in event of sling or hoist failure. Disregard of this warning could result in grave personal injury.

5. Place sling around inlet pipe for support. Remove the bolts on the inlet hub packing plate and check valve packing plate. Slide both packing plates back on inlet pipe. Inlet filler pipe (23) will now slide out of position for removal.

VCS PUMP REMOVAL: (Refer to page 10 for Item Numbers.)

Once the inlet filler pipe has been removed, disconnect the union or flange at discharge pipe near discharge elbow. Refer to VCS Bulletin 4847583 for instruction for pump removal from basin.

UW PUMP REMOVAL:

1. Once the inlet filler pipe has been removed, disconnect the discharge pipe companion flange (8) by removing screws, nuts, and gaskets (11) (12) (13) Unscrew companion flange from discharge pipe. Disconnect discharge flange from basin cover and pull discharge pipe through basin cover.

WARNING Pump unit will be unstable once the discharge pipe has been removed as the weight of the strainer casing and check valve tee will cause the unit to be off balance. Provide a support for the unit to prevent it from tipping over. Disregard of this warning could result in grave personal injury.

2. Remove check valve tee assembly (11) by removing screws, nuts, washers and gaskets (10) (12) (13) (16).

WARNING Check valve tee assembly is heavy; a hoist, or other lifting device of proper capacity should be used to handle this assembly. Disregard of this warning could result in grave personal injury.

3 Remove strainer casing by pulling in an upward motion, twisting at the same time until it clears the strainer rods

4. Remove strainer rod assembly (9) by removing screws and washers (1) (16) from pump discharge flange.

5 Tag electrical leads for connection at reinstallation and disconnect motor cables. Loosen motor grip cables at basin cover and pull motor cable from cover.

6. Attach cable or sling to pump lugs and lift pump from basin with a hoist of proper capacity.

Refer to UW Pump Bulletin 2899213 for instructions on pump unit.

Disassembly of Inlet Hub Assembly and Check Valve Assembly.

1. Refer to pages 8 and 9 for detailed drawings for aid in disassembly of these two units.

**CONCRETE MOUNTED INLET HUB
FOR TYPE F AND FI SERIES P FLUSH KLEEN**

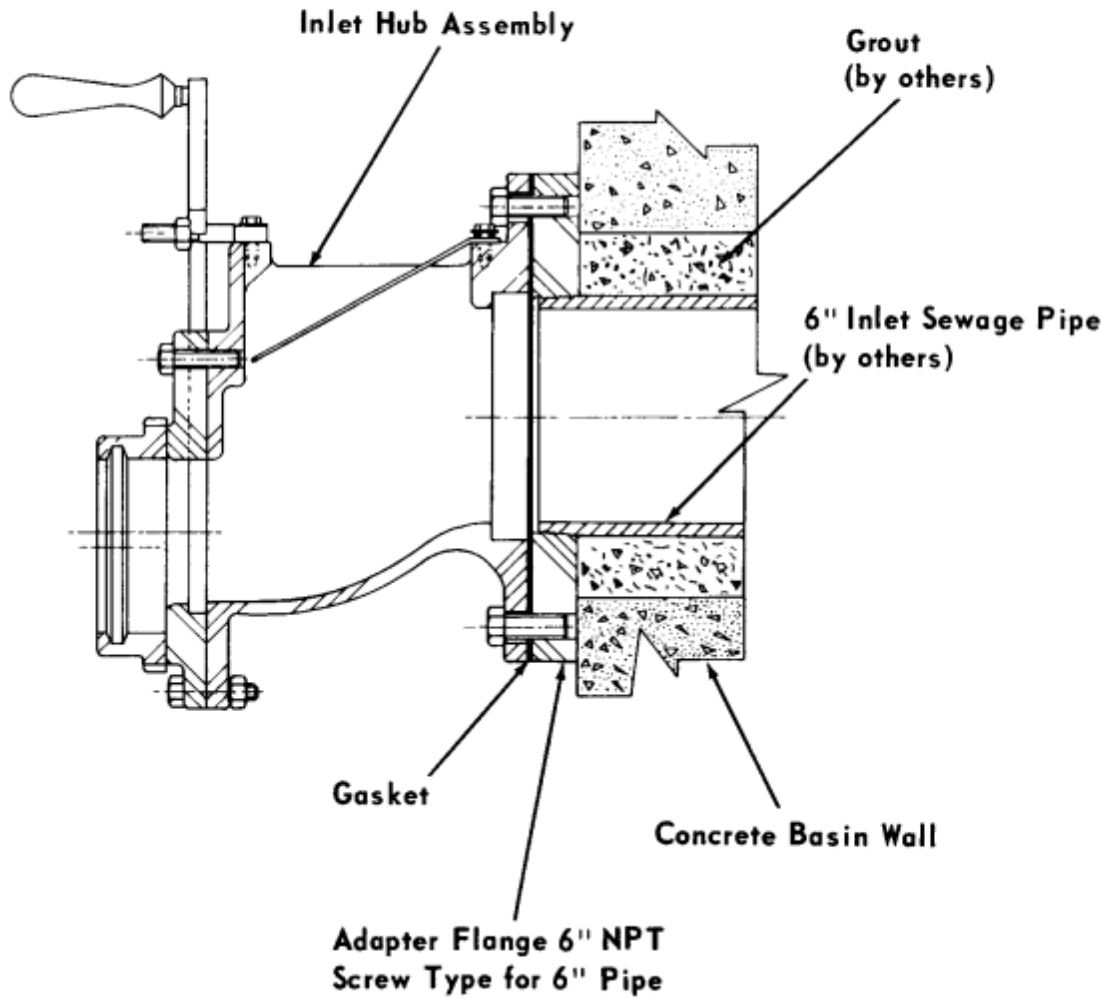

**INLET HUB ASSEMBLY
FOR TYPE F AND FI SERIES P FLUSH KLEEN**

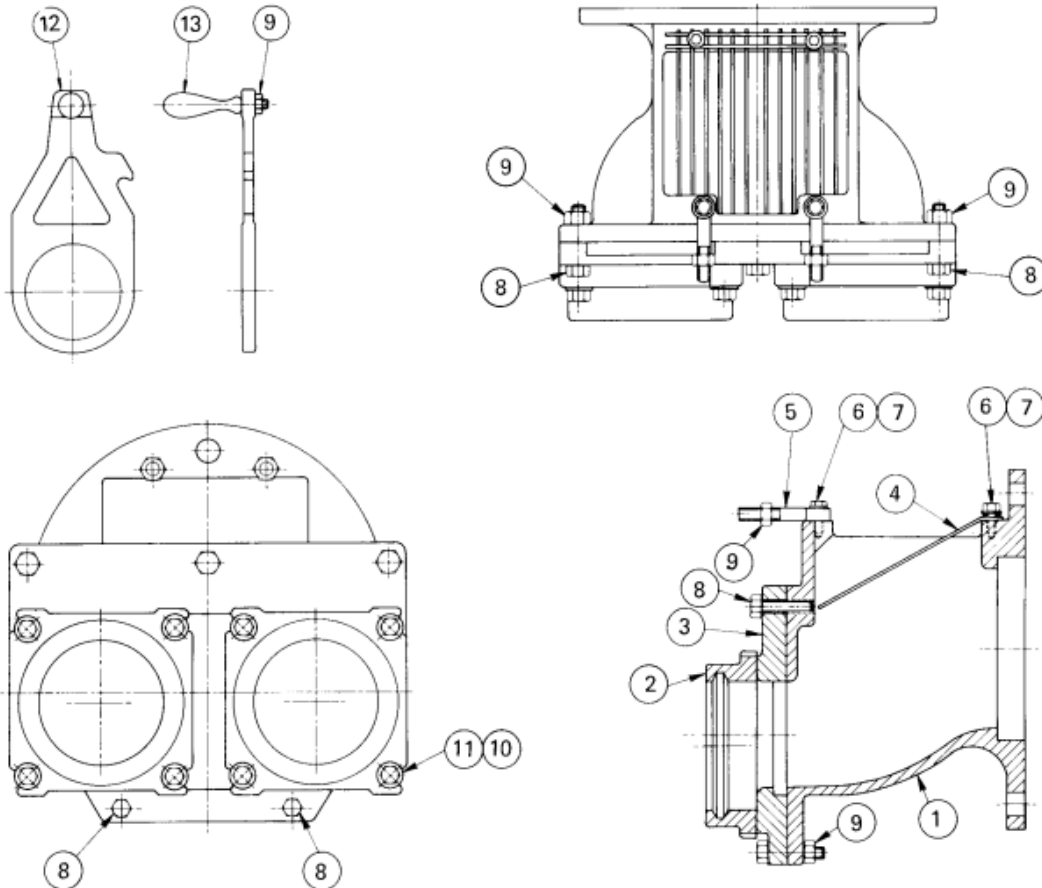

Item	Quantity	Description	Material Description	Part Number	Material Code
1 through 11	-	Inlet Hub Assembly	Assembly	2688386	000
1	1	Inlet Hub	Cast Iron	2688015	040
2	2	Packing Plate	Cast Iron	2688112	040
3	1	Shut-Off Housing	Cast Iron	2688096	040
4	1	Overflow Strainer	Stainless Steel	2688040	079
5	2	Gland Bolt	Stainless Steel	2666667	086
6	4	Cap Screw 1/4-20 x 7/8 long	Stainless Steel	2609990	079
7	4	Washer 1/4 x 5/8 x 9/32	Zinc Plated. Steel	2610411	217
8	5	Cap Screw 1/2-13 x 2 long	Stainless Steel	2610064	079
9	7	Nut Hex 1/2-13	Stainless Steel	2609814	291
10	8	Cap Screw 1/2-13 x 1-1/2 long	Stainless Steel	2610062	079
11	8	Washer 1/2 x 1-1/16 x 17/32	Zinc Plated. Steel	2610419	217
*12	2	Shut-Off Plate	Bronze	2688114	011
*13	2	Handle - Shut-Off Plate	Steel	2688221	056

* Items 12 & 13 are not part of Inlet Hub Assembly and are to be ordered separately.

TEE AND CHECK VALVE ASSEMBLY FOR TYPE F AND F I SERIES P FLUSH KLEEN

Right Hand
Check Valve Assembly
Part Number 268838702

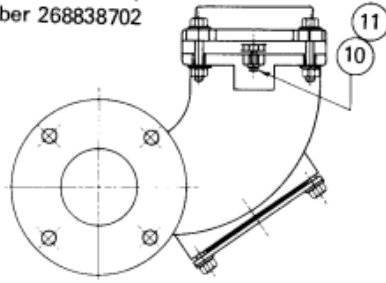

Left Hand
Check Valve Assembly
Part Number 268838701

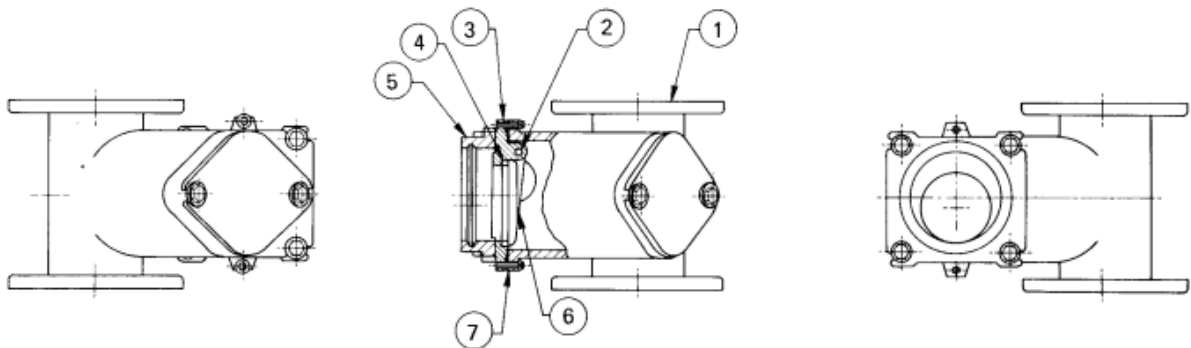
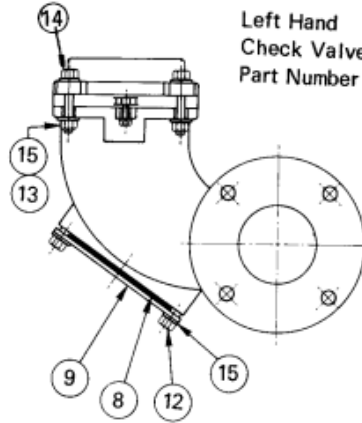

Item	Quantity	Description	Material Description	Part Number	Material Code
1	1	Tee Body	Cast Iron	2688111	040
2	1	Check Valve Pin	Bronze	2688248	295
3	1	Check Valve Plate	Cast Iron	2688113	040
4	1	Check Valve Seat Ring	Bronze	2688220	186
5	1	Packing Plate	Cast Iron	2688112	040
6	1	Check Valve Disc	Bronze	2688247	011
7	1	Gasket Check Valve	Rubber	2688223	364
8	1	Gasket Hand hole	Rubber	2688326	364
9	1	Hand hole Cover	Cast Iron	2688324	040
10	2	Washer 1/4 x 5/8 x 9/32	Zinc Plated. Steel	2610411	217
11	2	Cap Screw 1/4-20 x 1-1/4 long	Stainless Steel	2609992	291
12	2	Cap Screw 1/2-13 x 7/8 long	Stainless Steel	2685767	175079
13	4	Nut Hex 1/2-13	Stainless Steel	2609814	291
14	4	Cap Screw 1/2-13 x 3 long	Zinc Plated. Steel	2610068	217
15	4	Washer 1/2 x 1-1/16 x 17/32	Zinc Plated. Steel	2610419	217

Quantities are per each assembly.

Flush Kleen Series P Assembly Component Parts

Item	Quantity	Description	Material Description	Part Number	Material Code
1	4	Cap Screw 5/8-11 X 1-3/4 Long	18-8 Stn. Stil.	2610085	079
2	4	Cap Screw 5/8-11 X 1 Long	18-8 Stn. Stil.	2610082	079
3	2	Strainer Plate	18-8 Stn. Stil.	2688125	079
4	2	Gasket Strainer Plate	Rub.	2688126	364
5	2	Strainer Housing	C.I.	2688067	040
6	2	O-Ring Casing	Rub.	L 5 28 2	364
7	2	Strainer Casing	C.I.	Length Cut To Job	040
8	2	4" Companion Flange	C.I.	2655542	040
9	2	Strainer Assembly	18-8 Stn. Stil.	2688226	079
10	4	Gasket 125# 4"	Rubber	2652035	112
11	1	Check Valve Tee Assembly L. H.	Assembly	268838701	000
	1	Check Valve Tee Assembly R. H.	Assembly	268838702	000
12	20	Cap Screw 5/8-11 X 2-1/4 Long	18-8 Stn. Stil.	2610088	079
13	20	Nut Hex 5/8-11	18-8 Stn. Stil.	2609815	079
14	2	4" Discharge Pipe	Steel	Length Cut To Job	360
15	2	Gasket Discharge Flange	Rubber	Lm4 39	364
16	20	Washer 5/8 X 1-5/16 X 21/32	Galvanized Steel	2610421	217
17	4	O-Ring Inlet Pipe	Rub.	Lm4 28	375
18	1	Inlet Hub Assembly	Assembly	2688386	000
19	1	Adapter Inlet Hub Round Basin Only	C.I.	2688115	040
20	1	Gasket Inlet Hub	Cork Rubber	2688282	254
21	4	Cap Screw 3/4-10 X 3 Long	18-8 Stn. Stil.	2610111	079
22	4	Nut Hex 3/4-10	18-8 Stn. Stil.	2609842	079

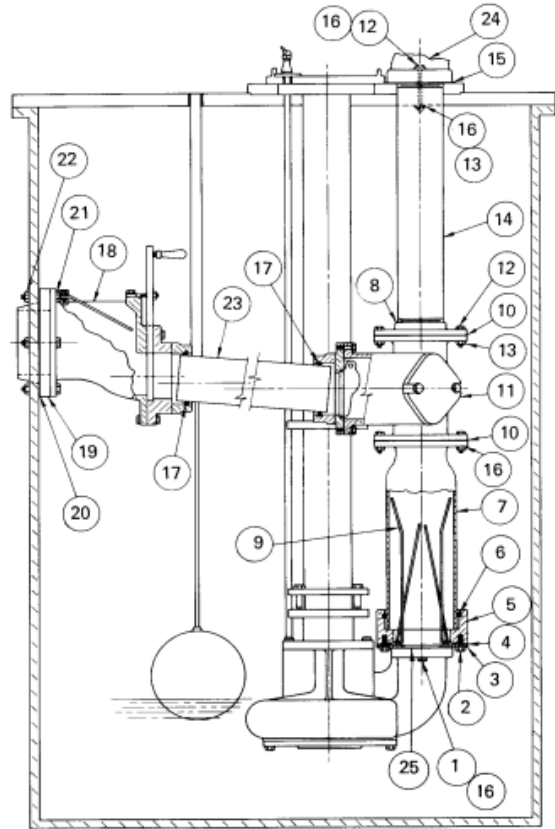

Item	Quantity	Description	Material Description	Part Number	Material Code
23	2	Inlet Pipe 48 Dia Basin	Steel	268829201	360
	2	Inlet Pipe 60 Dia Basin	Steel	268829202	360
	2	Inlet Pipe 72 Dia Basin	Steel	268829203	360
	2	Inlet Pipe 48 Sq. Basin	Steel	268829204	360
	2	Inlet Pipe 60 Sq. Basin	Steel	268829205	360
	2	Inlet Pipe 72 Sq. Basin	Steel	268829206	360
24	2	Discharge Elbow 45 Flanged	C.I.	Lm4 25 3	040
	2	Discharge Elbow 45 Threaded	C.I.	Lm4 25	040
Not Shown	1	Inlet Hub Adapter For Concrete Basins Round Or Square	Steel	2688683	056
25	2	Gasket Pump Discharge Flange	Rubber	LM4 39	364

Parts List Subject To Change Without Notice

**INLET HUB MOUNTING DETAIL
FLUSH KLEEN SERIES P**

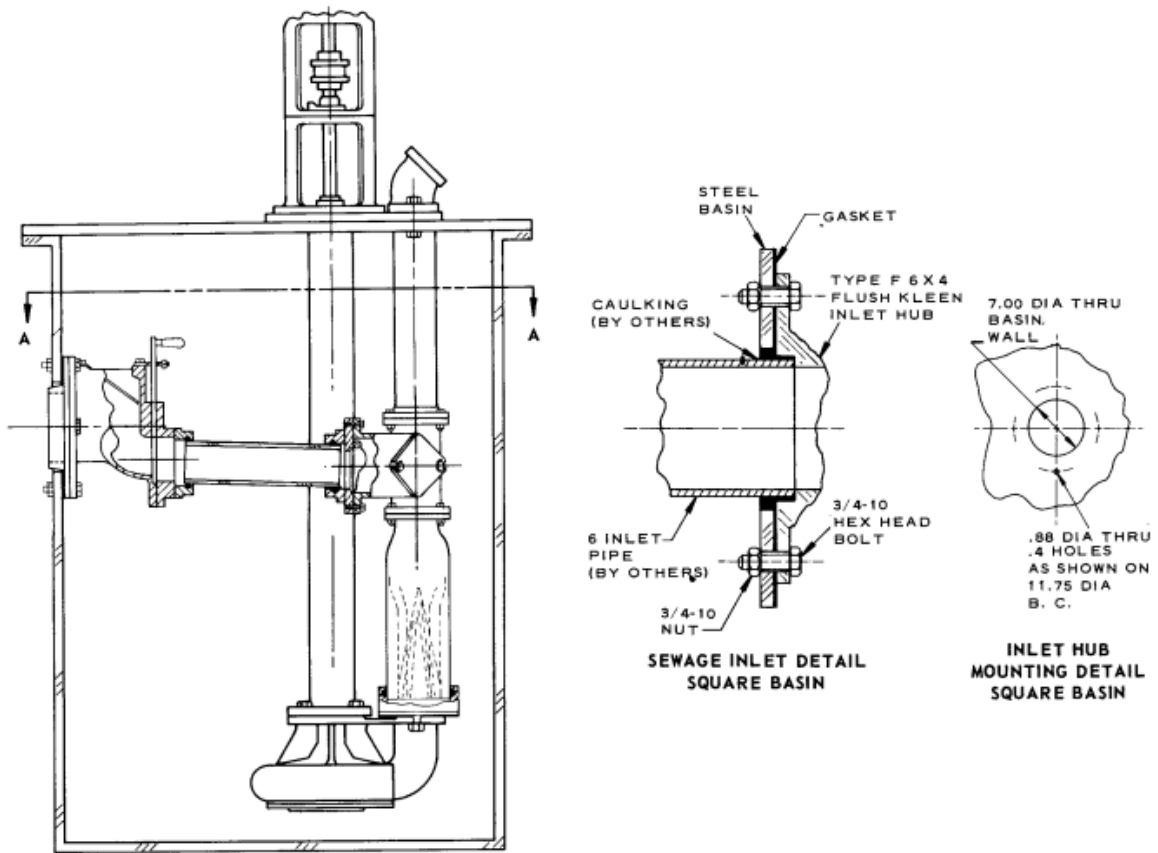
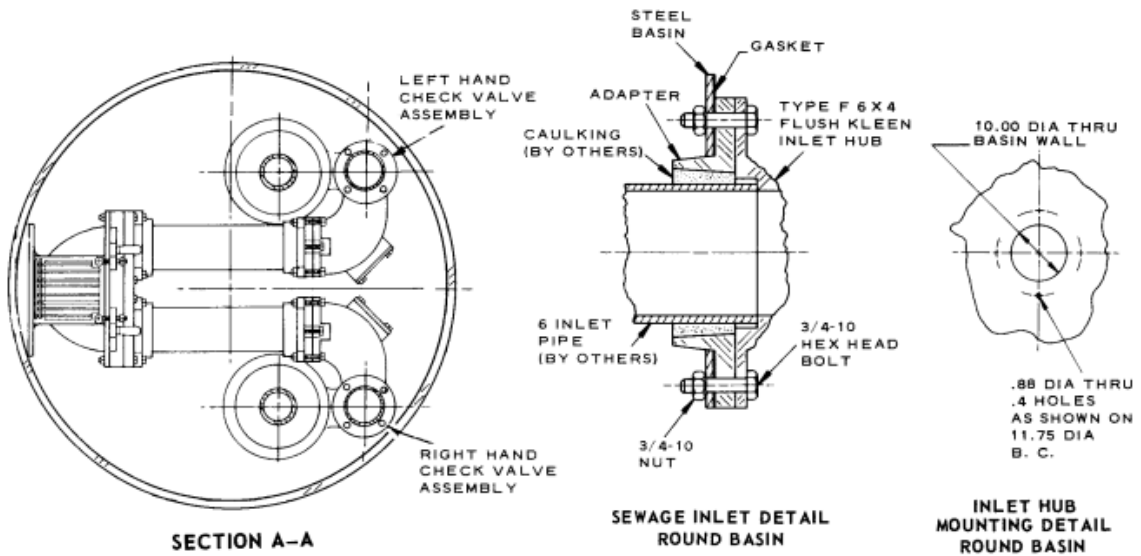

Rev 7-2022

