



2022

TYPE THV PUMPS

MAINTENANCE AND REPAIR INSTRUCTIONS



TABLE OF CONTENTS

Maintenance	Page 2 & 3	Disassembly	Page 6 & 7
Impeller Clearance	4	Reassembly	7 & 8
Pressure – Temperature Limits	4	Fastener Torque Values	7
Troubles	4 & 5	Parts List	8 & 10
Spare Parts	5	Cross Section Drawings	9 & 10

MAINTENANCE

WARNING

Disconnect power to the pump driver before starting any repairs.

5-1. Regular, consistent maintenance is the best way to avoid serious trouble which may require taking the pump out of service for extensive repair. As the bearings and stuffing boxes are most important for good operation particular care should be taken in their maintenance.

5-2. BEARINGS. It is most important to provide proper lubrication and keep bearings clean. Frequency of lubrication must be determined by experience as it depends upon bearing size, speed, operating conditions and location (environment). Table I should be used as a guide for grease re-lubrication.

**TABLE I
LUBRICATION INTERVALS**

Service	To 1800 RPM	To 3600 RPM
Normal, 8-hour day operation. Room free of dust and damaging atmosphere.	6 Months	3 Months
Severe, 24-hour day operation. Room with moderate dust and/or damaging atmosphere, or outdoor service.	1 Month	2 Weeks
Light, approximately 10-hour week. Room relatively free of dust and damaging atmosphere.	12 Months	6 Months

5-3. CLEANING. Clean bearings in the following manner after 2 years operation; more often, if the pump is in severe service.

- a. Remove bearing from the housings, referring to disassembly instructions.
- b. Place bearings in a wire basket – so there is space for the cleaning solvent to reach all parts.
- c. Immerse the basket in Stoddard solvent, agitating the basket until grease is thoroughly loosened and can be flushed out.
- d. Place bearing on a screened surface.
- e. Using a spray gun with air filter and clean Stoddard solvent flush each bearing until all grease and sludge is removed.
- f. Blow solvent out of bearings with dry filtered air.
- g. Lubricate bearings immediately after cleaning with light spindle oil and place them in a covered container.
- h. Do not spin bearings any time during cleaning.

5-4. REMOVAL OR REPLACEMENT. Refer to the Disassembly instructions for the specific type pump for disassembly to the point of removing bearings from the shaft. Normally they should be removed only to clean and inspect after operating trouble is traced to the bearings.

5-5. INSPECTION. After bearings have been cleaned, inspect visually for defects given in Table II. Replace any bearing having any defect listed.

LUBRICATION AMOUNTS

PUMP SIZE	BEARING SIZE	OUNCES	GRAMS
25 & 32	06	.25	7
40 & 50	07	.30	8.5



TABLE II
BEARING DEFECTS
(Failures – Replace if found.)

DEFECT (Failure)	APPEARANCE	PROBABLE CAUSE
Flaking and cracking	In the early stages the surface of the inner and outer races develop small cracks, which flake. The cracks and flaking ultimately spread over the entire race surface.	1. Normal fatigue failure. 2. Bearing loads in excess of bearing capacity caused by misalignment.
Indentation	Indentations or cavities in the inner and outer races.	1. Dirt in the bearings. 2. Excessive impact loading of the bearings such as improper mounting or removal.
Broken separator (cage)	Cracked separator or separator in pieces.	1. Poor lubrication. 2. Misalignment of shaft. 3. Excessive shaft deflection.
Wear	Bore and OD of outer ring of bearing galled or braided.	1. Fit on shaft or in housing too loose. 2. Bearing locked by dirt and turning on shaft or in housing.
Fractured ring	Hairline cracks or complete ring fracture.	1. Forcing a cocked bearing on or off a shaft. 2. Too heavy a press fit.
Discoloration	Rolling elements and races darker than normal appearance of bearing metal. (Moderate discoloration of rolling elements and races not a reason for discard.)	1. Inadequate lubrication.
Corrosion	Rolling elements and raceways rusted.	1. Water entering the housing. 2. Condensation inside the housing. 3. Lubricant breaks down into acid. (Wrong lubricant)

5-6. Stuffing box. The stuffing box gland requires periodic adjustment to insure proper packing lubrication. When the pump is running, there must always be a slight leakage from the gland. The amount of leakage required for proper lubrication is hard to define but we recommend a steady dripping of water through the gland.

5-7. When leakage is excessive, tighten all of the gland bolts evenly while pump is running, approximately one-quarter turn at a time. Allow an interval for the packing to adjust to new position. Proceed slowly until the required liquid flow is achieved. Never tighten the gland to be leak proof as this will cause damage to the stuffing box components.

Pump Size	Number of Packing Rings
25 & 32	4
40 & 50	6

5-8. REPACKING. Replace packing in the stuffing box as follows:

- a. Close suction and discharge line valves and any other valves in auxiliary cooling, vent or packing seal lines. Drain the suction casing (1C) by removing the drain plug at the bottom of the casing.

- b. Take precaution to prevent driver being inadvertently started – tie disconnect switch open, remove fuses or use other means as applicable.
- c. Remove packing gland, referring to disassembly instructions for the pump.
- d. Remove and discard old packing rings.
- e. Clean out the stuffing box.
- f. Insert rings of packing as required and lightly tamp them to seat them against the bottom of the box.
- g. Install the gland and install gland stud nuts until they are just snug. After the pump is running, tighten these nuts as required to control leakage properly.

NOTE

If a mechanical seal is used, follow the seal manufacturer's instructions for removal, assembly and/or adjustment.

CAUTION IF FLUID IS HOT!



PRESSURE – TEMPERATURE – RPM LIMITS

SUCTION:

Structural: 250°F and 230 PSIG maximum
(121°C and 1585 kPa)

Uncooled Packing: Structural limits permissible

Mechanical Seal: Pressure versus temperature maximums permissible vary with RPM, pump size and seal seat material. Refer to the Peerless representative for specific details if operating conditions will not be the same as you specified at the time of the pump selection and order placement.

Temperature		Maximum Discharge Pressure	
°F	°C	PSIG	KPa
To 100	37.8	400	2757
175	79.4	379	2612
250	121.0	360	2482

RPM is limited to 3600 unless specific quotation is made for higher RPM.

5-9. IMPELLER CLEARANCE. The nominal diametrical clearances between the impeller sealing diameters and mating bore diameters in stationary parts is as listed. Radial clearances are 1/2 (half) of diametral clearances.

DIAMETRAL CLEARANCE

SIZE	New. Nominal		Worn. Mazimum	
	INCH	MM	INCH	MM
25	.010	.25	.020	.50
32	.010	.25	.020	.50
40	.010	.25	.020	.50
50	.010	.25	.020	.50

5-10. TROUBLES. To reliable establish the malfunctioning of either the pump or driver, instruments such as tachometers, pressure gauges and electric meters, must be in proper working condition and preferably of recent calibration. In many cases, much time and expense has been expended with faulty instruments. Table III list a number of troubles commonly occurring. If unable to determine the cause, and remedy the trouble, from this list, refer the problem to the Peerless representative.

TABLE III – TROUBLES

TROUBLE	PROBABLE CAUSE	REMEDY
Failure to deliver liquid or sufficient pressure	Pump not primed	Reprime
	Pump not up to speed	Check for low motor overload. Other drives, increase driver speed when possible
	Discharge head too high	Check to see that all discharge valves are opened and the discharge line is free from obstructions. In some cases, the installation has to be altered or a ump of suitable rating must be provided.
	Insufficient available NPSH	Check NPSH requirements of pump and increase system NPSH accordingly
	Incorrect direction of rotation	Check rotation of driver
	Air leaks in suction line	Tighten packing
	Suction pressure below atmospheric	Check suction line joints for air leakage. Check mechanical seal if installed
	Impeller passages restricted	Disassemble the pump and clean impellers
	Worn impeller sealing diameters of mating stationary part bores	Repair or replace impellers and/or stationary parts
	Damaged impellers	Repair or replace impellers
	Foot valve too small or restricted by dirt	Replace with adequate size foot valve or clean foot valve
	Leaking discharge check valve on standby pump	Repair or replace
	Recirculation valve open or leaking	Close, repair or replace



TABLE III – TROUBLES (continued)

TROUBLE	PROBABLE CAUSE	REMEDY
Pump loses prime after starting	Air leaks in suction line Insufficient available NPSH	Tighten packing. Check for air leaks between sleeve and shaft and replace. O-Ring if there is an air leak. Check all suction line joints for bad gaskets and loose joints. Check NPSH requirements of the pump and increase the system available NPSH accordingly.
Overload on driver	Pump speed high Total head lower than rating Tight packing Liquid is of higher specific gravity or viscosity than rating Mechanical trouble of pump or driver	Motor voltage higher than name plate rating will cause the motor to run faster. Either reduce motor voltage or trim impeller diameter. On other drives, reduce speed if possible. If speed reduction not realized, trim impeller diameter.** Check suction and discharge pressures and determine the total dynamic head. If TDH lower than ratings, throttle discharge to rated TDH or if this is not possible, reduce impeller diameter** Stop pump – follow proper repacking procedure. Check for scored sleeve; and for sleeve run-out if packing wears rapidly. Replace sleeve and packing as required Check with Peerless distributor to determine if a larger motor is required See if pump and motor turn freely. Check impeller fit, shaft straightness and bearings.
Pump vibrates or is noisy	Driver unbalanced, pump clogged Cracked foundation Worn bearings Unbalance impellers Bent shaft	Disconnect driver and operate it alone. Check pump for large pieces of debris, such as wood, rags, etc. Replace foundation Replace bearings; check lubricants for proper grade Rebalance Replace

**Always obtain new trim diameter from Peerless representative.

5-11. SPARE PARTS. To keep delays to a minimum when pump repairs are required, we suggest that the following spare parts be stocked. The number of each part required depends upon the application. For a minimum, we recommend:

- (A) One bearing.
- (B) One set of shaft sleeves for packed pumps.
- (C) 2-4 sets of packing for packed pumps or a mechanical seal for pumps so equipped.
- (D) In some cases, an entire rotating element should be stocked.

5-12. To obtain quick and accurate service when ordering spare parts, provide the following information:

- (A) Pump size and type as noted on nameplate.
- (B) Pump serial number as noted on nameplate.
- (C) The name and number of the parts as shown on the sectional drawings.
- (D) Quantity required of each item.

Aid may be obtained from the Peerless representative, or a authorized distributor, for planning an adequate supply of spare parts.



REPAIR DISASSEMBLY – ASSEMBLY

TYPE THV MULTISTAGE PUMP

Preparation for Service Work

Refer to Sectional Drawing supplied in these instructions.

Close suction and discharge line valves and any other valves in auxiliary cooling, vent or packing seal lines. Drain the suction casing (1C) by removing the drain plug.

CAUTION IF FLUID IS HOT!

NOTE: If only the ball bearing (18) or the stuffing box is to be reserviced, the pump need not be disconnected from system piping.

Disconnect the flexible coupling between the pump and the driver and remove the motor with suitable and safe lifting means. Remove the pump half coupling using a suitable puller; never drive off the coupling half using hammer blows. Use heat only if it is known that there can be no damage to the coupling parts. Remove coupling key (46).

Always disassemble the pump from the discharge end. All threads are right-hand unless noted specifically – and are metric.

DISASSEMBLY

Disassembly of the THV pump is as follows if more than just packing replacement is required.

1. Drain the pump.
2. Remove the motor with its coupling half. Remove the bolts holding pedestal (81) to the bearing housing (99) and remove the pedestal.
3. Remove the pump half coupling and key (46).
4. Remove bearing cap (41).
5. Remove bearing lock washer (69) and bearing lock nut (22).
6. Remove nuts and flat washers from the upper end of the tie bolts.
7. Remove bearing housing (99) by lifting it up. Ball bearing (18) will be removed from the shaft during this operation.
8. Remove deflector (40) and spacing sleeve (14B).

9. a) When packing is supplied:

Remove discharge casing (1D) with gland (17) and packing rings (13) by lifting the discharge casing vertically. Go to step 10.

- b) If mechanical seal is supplied:

- 1) Remove the mechanical seal circulating tubing from seal flange (17H) and discharge casing (1D).
- 2) Remove seal flange (17H) with stationary seat (65H) and set the two aside carefully to protect the seat.
- 3) Remove the mechanical seal rotary unit (80H) from the sleeve (14F) and set this aside carefully to protect the seal surfaces.

10. Remove shaft sleeve (14) for the packed pump or (14F) for the sealed pump with its "O" ring (14E).
11. Remove last stage impeller (2), stage casing (1F), "O" ring (1H), diffuser (5) and impeller key (32).
12. Repeat step 11 for as many stages as are supplied until all are removed.
13. Lift shaft (6) with impeller hub sleeve (34) out of the suction casing (1C).
14. Check the condition of the bearing surface of both the impeller hub sleeve (34) and the bearing bushing (39) located in the suction casing, (1C). The maximum recommended diametral clearance between the OD of the two parts is .006" (0.15mm). If this clearance is exceeded, first check clearance with a new impeller hub sleeve (34). Note: Thread is left hand. If clearance is still excessive, it will be necessary to replace the bushing (39). One or both parts also must be replaced if the surfaces are badly scored or worn. To replace bushing (39) it is necessary to destroy the bushing by suitable means since it was installed with an adhesive into the suction casing (1C). After the bushing's removal, the bore in the suction casing is to be thoroughly cleaned and dried and the replacement bushing (39) is to be coated on its bottom end and on its OD with an adhesive similar or identical to Loctite Type 270. The bushing should be pressed into the suction casing (1C) with a tool that may be purchased from Peerless Pump or may be made by reducing approximately a 1" length of a round bar to a diameter that fits closely into the bore of the bushing (39). This



tool should be made of steel and is used to press the bushing into place until the upper surface of the bushing is flush with the bore in the suction casing (1C).

- Clean all parts, check for wear or damage. Check for damage to impeller hub surfaces and other surfaces where parts abut each other along the shaft. These surfaces must be smooth, square to the bore and clean. If bearing (18) requires replacement, drive it out of the bearing housing, (99), otherwise, leave it in place.

REASSEMBLY

All original parts to be re-used must have been thoroughly cleaned and checked. New parts must be thoroughly cleaned.

CAUTION: Surfaces where "O" rings seat must be cleaned and free of burrs.

Assembly starts at the suction end of the pump. The suction casing (1C) with a checked and usable bushing (39) in place is placed on its base for assembly of the pump vertically from its upper surface.

- Thread impeller hub sleeve (34) on the lower end of the shaft (6) after applying an adhesive like Loctite Type 270 to the threads to secure the sleeve against loosening. **Note that the thread is left hand.** Thread the impeller hub sleeve (34) up fully against the shoulder of the shaft.
- Install the first stage impeller key (32) and impeller (2) on the shaft.
- Insert the shaft (4) with the impeller (2) and sleeve (34) just installed into the bearing bushing (39) in the suction casing (1C) using a small amount of bearing grease on both the outside diameter of the sleeve, (34) and the wear ring surface of the impeller, (2).
- Install the first intermediate stage casing, (1F) with its "O" ring (1H).

- Repeat the installation of each succeeding stage with its impeller key, impeller, intermediate stage casing diffuser and "O" ring until all stages have been installed. The discharge casing (1D) is next installed being sure that the shaft sleeve key (32A) has first been installed in the shaft (6). Position the discharge casing with its nozzle in the correct position with respect to the suction nozzle. Install the shaft sleeve (14) or (14F) with its "O" ring (14E).
- Install either the packing rings if not split or the rotary for the mechanical seal followed by the gland or the mechanical seal flange with stationary element.
- Install spacing sleeve (14B) with its deflector (40). Reinstall bearing housing, (99) with ball bearing (18).
- Install tie bolts with their nuts and flat washers and tighten loosely.
- Install bearing lockwasher (69) and bearing lock nut (22). Using the keyway in the shaft to prevent rotation, tighten the bearing lock nut (22) securely so that all parts on the shaft are tightly abutted to each other. Position a tang of the lock washer (69) in one of the lock nut grooves to lock the nut in position.
- Install bearing cap (41) with its cap screws.
- Install pedestal (81) on bearing housing (99) and reinstall the motor and shaft couplings as covered by coupling installation instructions.
- Now tighten the tie bolts diagonally, never in sequence, to the torque values shown in the fastener torque values table.
- For the mechanical sealed pump, install the circulation fittings and tubing between the seal flange (17H) and the tapped opening in the discharge casing (1D). For the packed pump, install the packing rings if split and adjust the packing gland as described elsewhere in this instruction.

FASTENER TORQUE VALUES

Location	Pump Size							
	25		32		40		50	
	L-Ft	N.m	Lb-Ft	N.m	Lb-Ft	N.m	Lb-Ft	N.m
Tie Bolts, 2-5 Stages	33-36	45-49						
Tie Bolts, 6 or more Stages	46-51	62-69	33-36	45-49				
Bearing Cap	8-9	11-12						
Bearing Housing to Casing	16-18	22-24			38-42	52-57		
Mech. Seal Flange Stud Nuts	12-14	16-19			30-33	41-45		
Bearing Locknut	73-75	99-102			108-112	146-152		



COUPLING INSTALLATION, TYPE THV PUMPS

The Woods coupling halves are mounted as follows. The pump is first assembled completely with pedestal (item 81) installed. The pump half coupling is mounted with its key (item 46) on the pup shaft (item 6) first with the pump shaft filling the coupling bore length completely.

Note: For the following pump sizes, coupling sizes and motor frame sizes; the pump coupling half is then raised by the amount in the "pull" column below. The coupling set screw is next tightened securely for all units.

THV PUMP SIZE	WOODS COUPLING SIZE	PULL DIMENSION		MOTOR FRAME SIZE
		INCHES	MM	
25	5	.31	8	182/184
32	5	.31	8	182/184
	8	.19	5	284/286
40	6	.31	8	182/184
	8, 9	.44	11	324/326
50	6	.31	8	184
	8, 9	.44	11	324/326
	9	.13	3	286 & 364

Check to be sure that the pump shaft either fills the pump coupling half coupling bore completely or that the end of the pump shaft is BELOW the top face of the pump half coupling bore by the dimension in the "Pull" column above. Proceed or correct the setting of the pump half coupling.

Mount the motor half coupling and its key on the TCV motor shaft locating it as far on the shaft as possible. Place the coupling sleeve in the pump half coupling and position the motor on the pedestal (item 81) register. Now, lower the motor half coupling until the space between the rim of the coupling halves equals the "G" dimension tabulated in instruction bulletin 2880549, pages 9 and 10. Tighten the set screw securely in the motor half coupling to complete the installation.

PARTS LIST TYPE THV WITH PACKING MULTISTAGE PUMP

Item No.	Description	Item No.	Description
1C	Suction Casing	18	Ball Bearing
1D	Discharge Casing	22	Bearing Locknut
1F	Stage Casing	32	Impeller Key
1H	"O" Ring	32A	Shaft Sleeve Key
2	Impeller	34	Impeller Hub Sleeve
5	Diffuser	39	Bearing Bushing
6	Shaft	40	Deflector
13	Packing	41	Bearing Cap
14	Shaft Sleeve	46	Coupling Key
14B	Spacing Sleeve	69	Bearing Lock Washer
14E	"O" Ring	81	Motor Pedestal
17	Gland	99	Bearing Housing



CROSS SECTIONAL DRAWING 4851651
Type THV with Packing

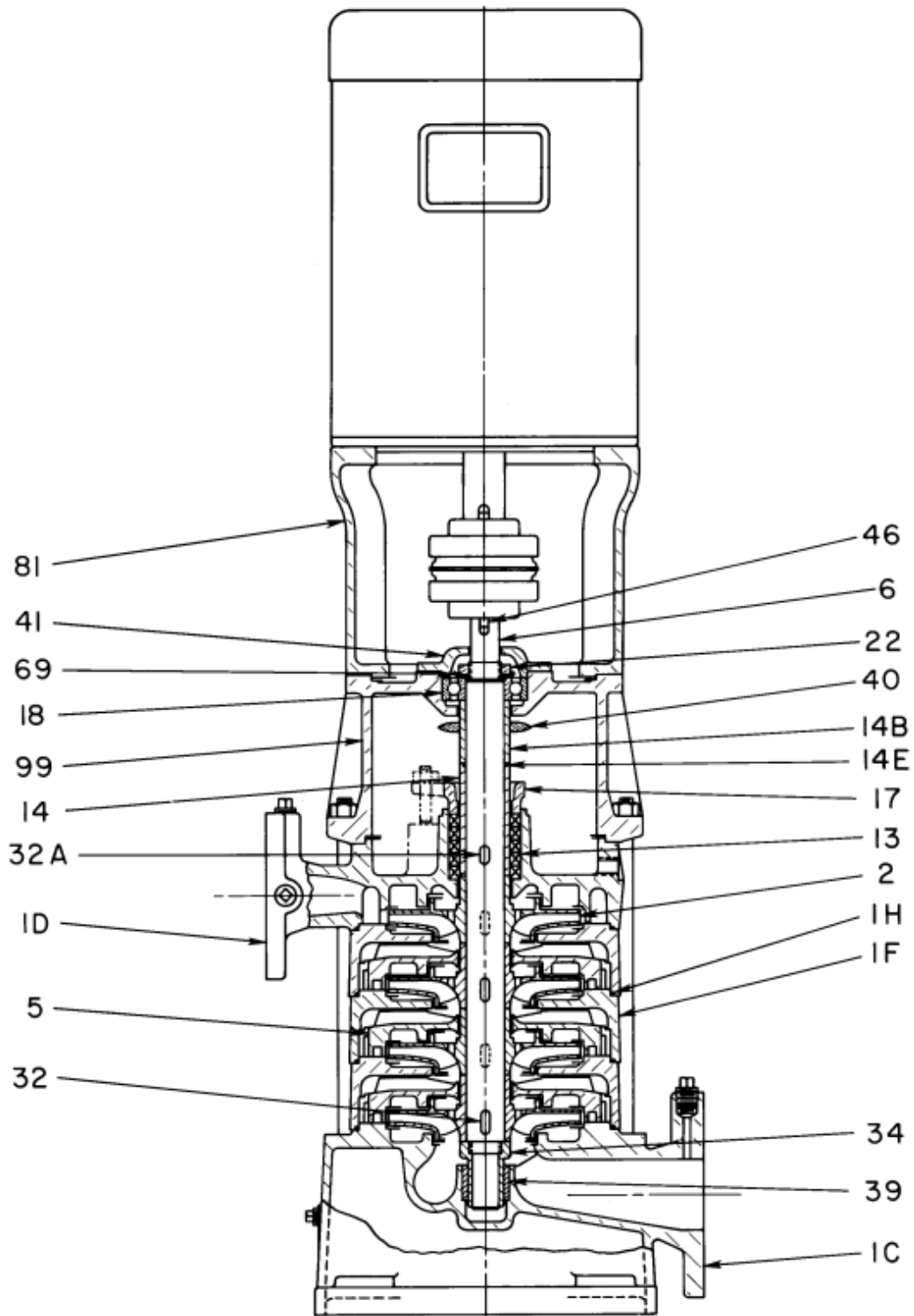

**PARTS LIST
TYPE THV WITH PACKING
MULTISTAGE PUMP**

Item No.	Description	Item No.	Description
1C	Suction Casing	32	Impeller Key
1D	Discharge Casing	32A	Shaft Sleeve Key
1F	Stage Casing	34	Impeller Hub Sleeve
1H	"O" Ring	39	Bearing Bushing
2	Impeller	40	Deflector
5	Diffuser	41	Bearing Cap
6	Shaft	46	Coupling Key
14B	Spacing Sleeve	65H	Seal Seat, HP
14E	"O" Ring	69	Bearing Lock Washer
14F	Shaft Sleeve	73C	Gasket
17H	Gland – Seal, HP	80H	Seal Head, HP
18	Ball Bearing	80P	Piping
22	Bearing Locknut	81	Motor Pedestal
		99	Bearing Housing



CROSS SECTIONAL DRAWING 4851652
Type THV with Mechanical Seal

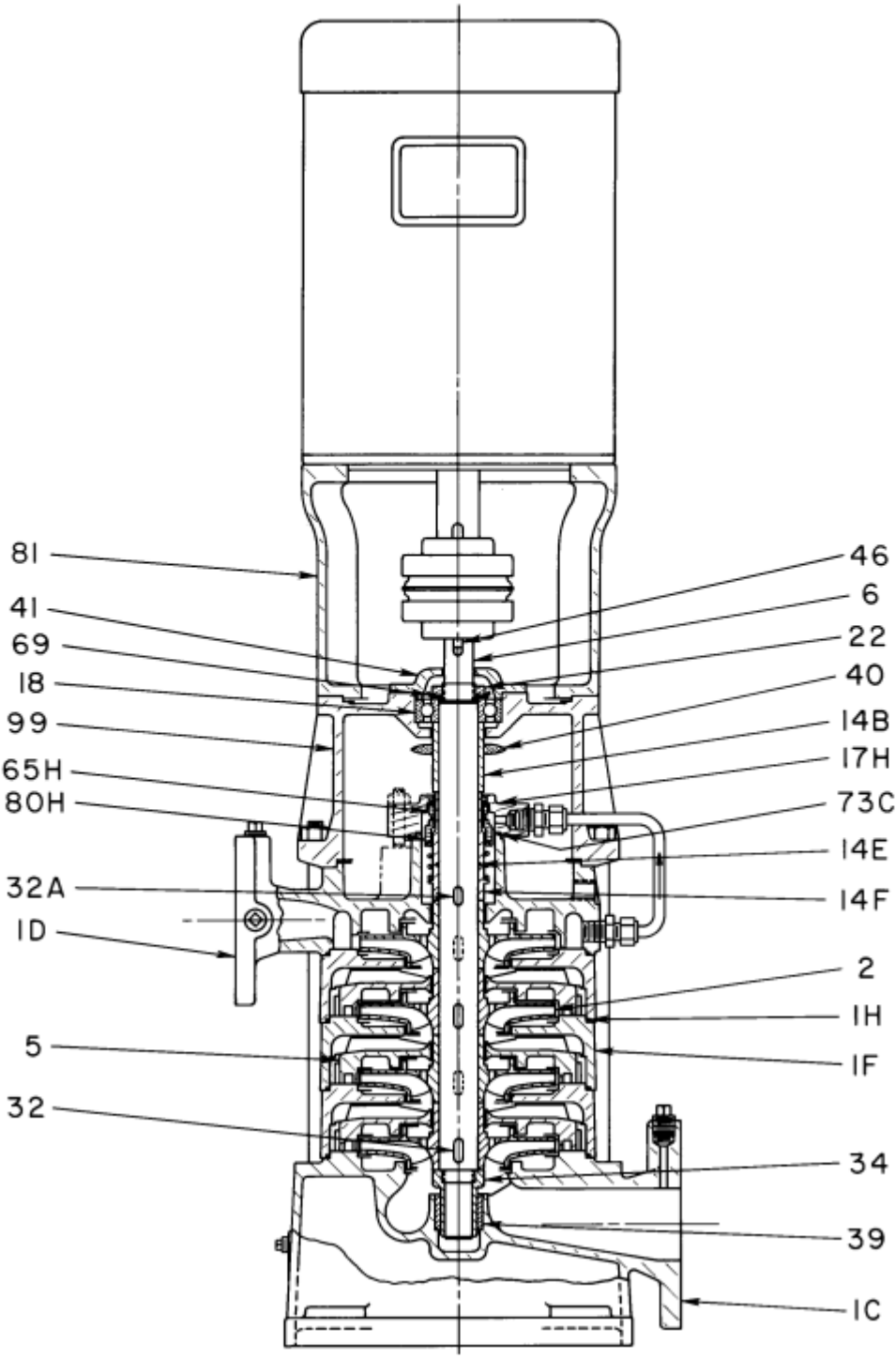

Rev 7-2022

