



2022 2022

2022

# TYPE UNF PUMPS PACKED

## REPAIR INSTRUCTIONS

### ***Read this entire bulletin***

before attempting to repair this pump. For installation and operation refer to instruction bulletin 2880549. Properly installed, your Peerless Pump will give you satisfactory, dependable service. We urge that you carefully read these step-by-step instructions, to simplify any problems of installation, operation of repair.

Failure to read and comply with installation and operating instructions will void the responsibility of the

manufacturer and may also result in bodily injury as well as property damage.

This bulletin is intended to be a permanent part of your pump installation and should be preserved in a convenient location for ready reference. If these instructions should become soiled, obtain a new copy from Peerless Pump Company. Include pump model and/or serial number with your request, both are stamped on the pump nameplate



## WARRANTY

New equipment manufactured by Seller is warranted to be free from defects in material and workmanship under normal use and service for a period of one year from date of shipment; Seller's obligation under this warranty being limited to repairing or replacing at its option any part found to its satisfaction to be so defective provided that such part is, upon request, returned to Seller's factory from which it was shipped, transportation prepaid. This warranty does not cover parts damaged by decomposition from chemical action or wear caused by abrasive materials, nor does it cover damage resulting from misuse, accident, neglect, or from improper operation, maintenance, installation, modification or adjustment. This warranty does not cover parts repaired outside Seller's factory without prior written approval. Seller makes no warranty as to starting equipment, electrical apparatus or other material not of its manufacture, since the same are usually covered by warranties of the respective manufacturers thereof.

In the event, notwithstanding the terms of this agreement, it is determined by a court of competent jurisdiction that an express warranty has been given by Seller to Purchaser with respect to the head, capacity or other like performance characteristics of said equipment, Seller's liability for breach of the same shall be limited to accepting return of such equipment F.O.B. plant of manufacture, refunding any amount paid thereon by Purchaser (less depreciation of the rate of 15% per year if Purchaser has used equipment for more than thirty (30) days and canceling any balance still owing on the equipment.

**THIS WARRANTY IS EXPRESSLY IN LIEU OF ANY OTHER WARRANTIES, EXPRESSED OR IMPLIED, AND SELLER SPECIFICALLY DISCLAIMS ANY IMPLIED WARRANTY OF MERCHANTABILITY OR FITNESS FOR A PARTICULAR PURPOSE.**

## WARNING

Do not operate this pump at any pressure, flow rate, or liquid temperature other than those for which the pump was originally purchased. Do not pump any other liquid than the one for which the pump was originally

purchased without the consent of Peerless Pump Company or its authorized representatives. Disregard of this warning can result in pump failures and serious personal injury or death.

## SECTION I - DISASSEMBLY

### General

If the pump has been maintained and serviced carefully, breakdowns which necessitate the pump being dismantled should not occur often. If fault occurs, cause should be located before dismantling. (See 'Operating troubles and their causes' under Operation Section). If the pump is being dismantled, all parts must be very carefully handled, avoiding blows and shocks. All parts must be carefully cleaned and tested for wear. Recondition or replace parts where necessary. Where new joints are made, correct thicknesses must be maintained. After re-assembly, the rotor must turn easily by hand, otherwise damage may occur.

### Disassembly

When dismantling the pump, the volute casing can remain fastened to the base and mounted in the pipe work. When using a spacer coupling, the driver need not be removed. Match-marking of parts is recommended before removing spacer. This ensures original state of mounting on re-assembly. Suitable extraction devices to be used when removing and mounting coupling halves. To avoid damage to bearings, the coupling halves must not be knocked on or off the shaft. To dismantle pump it is convenient to proceed in the following sequence: Drain liquid (VII) from the casing.

For units with a spacer coupling, remove the spacer, otherwise disconnect and remove the motor. Undo screws securing support foot to base. If fitted, disconnect the sealing liquid lines. Unscrew nuts from the volute casing studs. Remove the casing cover and the bearing housing (19) complete with rotor, using screwdrivers or similar tools which will fit into the gap between the volute casing (1) and the casing cover (11). After undoing the impeller nut (24) in a counter clock-wise direction, the impeller (2) can be pulled off. Remove stud nuts from bearing housing (19). Remove casing cover (11) with stuffing box packing (13), lantern ring (29) and gland (17), from the bearing housing (19). Dismantle shaft sleeve (14), gland (17), stuffing box packing (13) and lantern ring (29). Pull off deflector (40) from shaft (6). Unscrew hex screws and remove both bearing covers from the bearing housing (19). Drive the pump shaft out carefully (6) with its bearings in the direction of the drive end. Note: Care must be taken to ensure that the pump end bearings pass centrally through the bore of the drive end bearing housing.

### During and After Disassembly

*Peerless Pump Company does not recommend reuse of ball bearings after removal from the shaft. If you choose to clean and consider reuse, proceed as follows:*



Wash all old grease from ball bearings and housings with Kerosene or Stoddard solvent and dry bearings thoroughly by spinning by hand, or gently with clean dry compressed air. Renew them if they do not rotate smoothly with no sign of jamming and freely but without slackness, or if running surfaces of balls or races show any deterioration. Coat bearings with rust preventative oil and wrap in greaseproof paper. Mount shaft between centers or vee blocks. Check for eccentricity throughout entire length with a dial indicator; eccentricity must not exceed 0.003 inch total indicator reading. Check that

threads are clean and sharp. Surfaces on which bearings mount must be smooth, have a finish of 32 micro inches or better, and the shoulders square and free from nicks. Measure the OD of the impeller wear surface or impeller ring (2) and the ID of the casing ring (8). Compute the diametrical clearance (ID minus OD). If measured diametrical clearance exceeds two times .016 inch, repair to restore design clearance is recommended. ID surface of casing ring must be smooth and concentric with ring OD. If ID of casing ring (56.0) is grooved, scored or eccentric, replace the casing rings.

## SECTION II - REASSEMBLY

Ensure that all parts to be refitted (especially new parts) are free from burrs. With screw threads and abutting faces clean and free from damage. The assembly routine is carried out in reverse order of disassembly. After the shaft has been fitted and the bearing cover (37.0) has been secured, not forgetting gaskets, the axial clearance (end float) of the rotor is 0.027 to 0.050 inch. Note: Two (2) gaskets fitted at drive end to maintain this tolerance. If the shaft is to be fitted with new bearings it is necessary to heat these to 175° F. The bearings must locate against the shoulders of the shaft. Bearings fitted originally have normal clearance. When assembling the rotor, take care not to forget the gasket.

Push the stuffing box bushing (if used) to the rear of the stuffing box. Insert two packing rings, lantern ring (29) if provided, and three packing rings. Insert each ring separately and stagger joints of successive rings 90°. Insert the packing gland (17) and set the gland bolt nuts

finger tight - DO NOT USE WRENCH. Rotate the shaft by hand to check that it turns freely.

Relubricate the bearings. Grease fittings are located at each bearing location and shaft lip seals ensure that any surplus grease is trapped inside the bearing housing. It is important to provide proper lubrication and keep bearings clean. Frequency of lubrication must be determined by experience, as it depends upon bearing size, speed, operating conditions and environment. It is recommended that the bearings are re-lubricated with the application of .5 to .75 ounces of the recommended grease.

### RECOMMENDED GREASE LUBRICANTS:

International Standard - DIN 51825: KP2 K- 30.

As supplied with pump - TEXACO MULTIFAK ALL PURPOSE EP2.

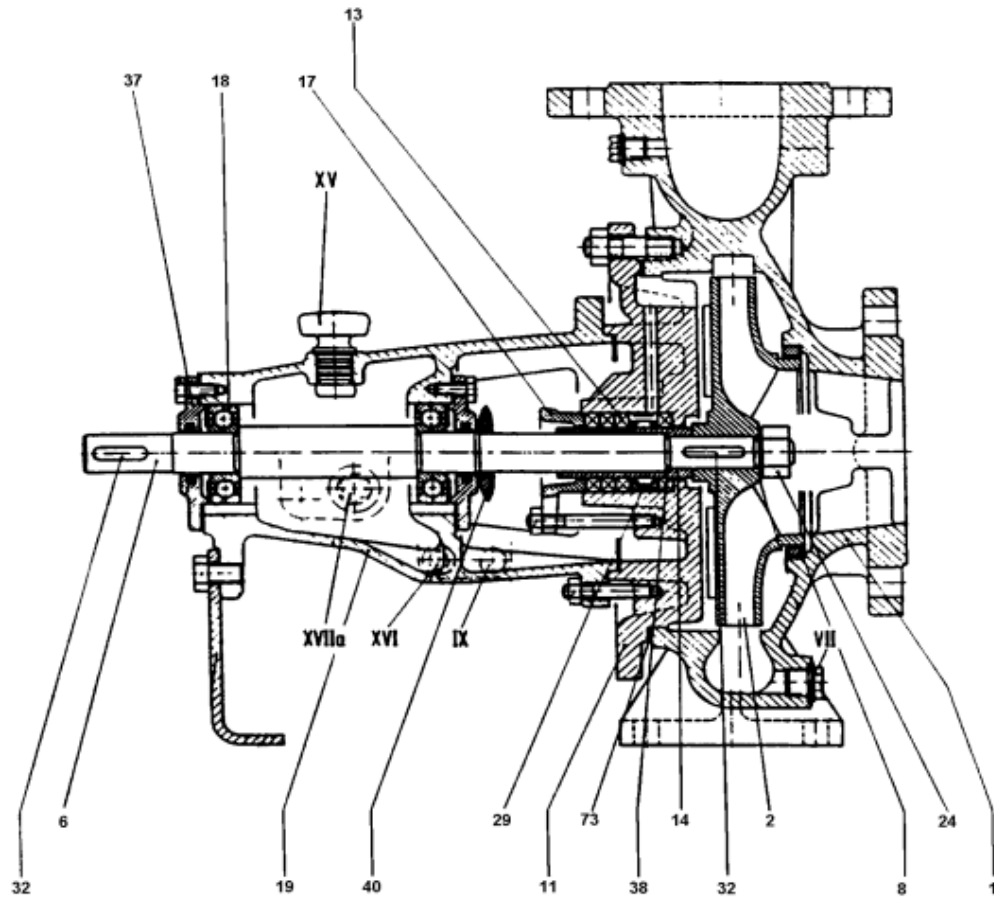

Item No.	Description	Item No.	Description
1	Case	18	Outboard Ball Bearing
2	Impeller	19	Frame
6	Shaft	24	Nut, Impeller
7	Casing Ring	29	Lantern Ring
8	Impeller Ring	32	Impeller Key
11	Casing Cover	37	Outboard Bearing Housing Cover
13	Packing Ring	38	Gasket, shaft sleeve
14	Shaft Sleeve	40	Deflector
17	Packing Gland	73	Casing Gasket

Figure 1

**TROUBLES.** To reliably establish the performance of either the pump or driver, instruments such as tachometers, pressure gauges and electric meters must be in proper working condition and preferably of recent calibration. In many cases, much time and expense have been expended with faulty instruments. Table VI lists a number of troubles commonly occurring. If unable to determine the cause, and remedy the trouble from this list, refer the problem to the Peerless Pump Company representative.

**TABLE I  
TROUBLES**

TROUBLE	PROBABLE CAUSE	REMEDY
Overload on driver	Pump speed high.  Total head lower than rating.  Tight packing.  Liquid is of higher specific gravity or viscosity than rating. Mechanical trouble of pump or driver.	Motor voltage higher than name plate rating will cause the motor to run faster. Either reduce motor voltage or trim impeller diameter. On other drives, reduce speed if possible. If speed reduction not realized, trim impeller diameter.** Check suction and discharge pressures and determine the total dynamic head. If TDH lower than ratings, throttle discharge to rated TDH or, if this is not possible, reduce impeller diameter.** Stop pump - follow proper repacking procedure. Check for scored sleeve; and for sleeve run-out if packing wears rapidly. Replace sleeve and packing as required. Check with Peerless Pump Company distributor to determine if a larger motor is required. See if pump and motor turn freely. Check impeller fit, shaft straightness and ball bearings.
Pump vibrates or is noisy	Driver unbalanced.  Misalignment. Cracked foundation. Worn ball bearings.	Disconnect driver and operate it alone. Check pump for large pieces of debris, such as wood, rags, etc. Realign pumping unit. Replace foundation.. Replace bearings. Check lubricants for proper grade. Check pump alignment.
Failure to deliver liquid or sufficient pressure	Pump not primed.  Pump not up to speed.  Discharge head too high.  Insufficient available NPSH.  Incorrect direction of rotation.  Air leaks in suction line or through stuffing boxes.  Impeller passages restricted. Worn wearing rings. Damaged impeller. Foot valve too small or restricted by dirt.	Re-prime.  Check for low motor voltage or motor overload. Other drives, increase driver speed when possible. Check to see that all discharge valves are opened and the discharge line is free from obstructions. In some cases, the installation has to be altered or a pump of suitable rating must be provided. Check NPSH requirements of pump and increase system NPSH accordingly. Check the impeller assembly for correct rotation either by removing upper case or through priming connection. Check rotation of driver. Tighten packing. Check for air leaks between sleeve and shaft and replace O-ring if there is an air leak. Check all suction line joints for bad gaskets and loose joints. Disassemble the pump and clean impeller. Replace worn parts. Replace or repair impeller. Replace with adequate size foot valve or clean foot valve.
Pump loses prime after starting	Air leaks in suction line.  Insufficient available NPSH.	Tighten packing. Check for air leaks between sleeve and shaft and replace O-ring if there is an air leak. Check all suction line joints for bad gaskets and loose joints. Check NPSH requirements of the pump and increase the system available NPSH accordingly.

\*\*Always obtain new trim diameter from Peerless Pump Company representative.



Rev 7-2022

