



2021



# PVF Vertical Inline Single Stage Pumps Installation, Operation and Maintenance Manual

Rev 07-2021

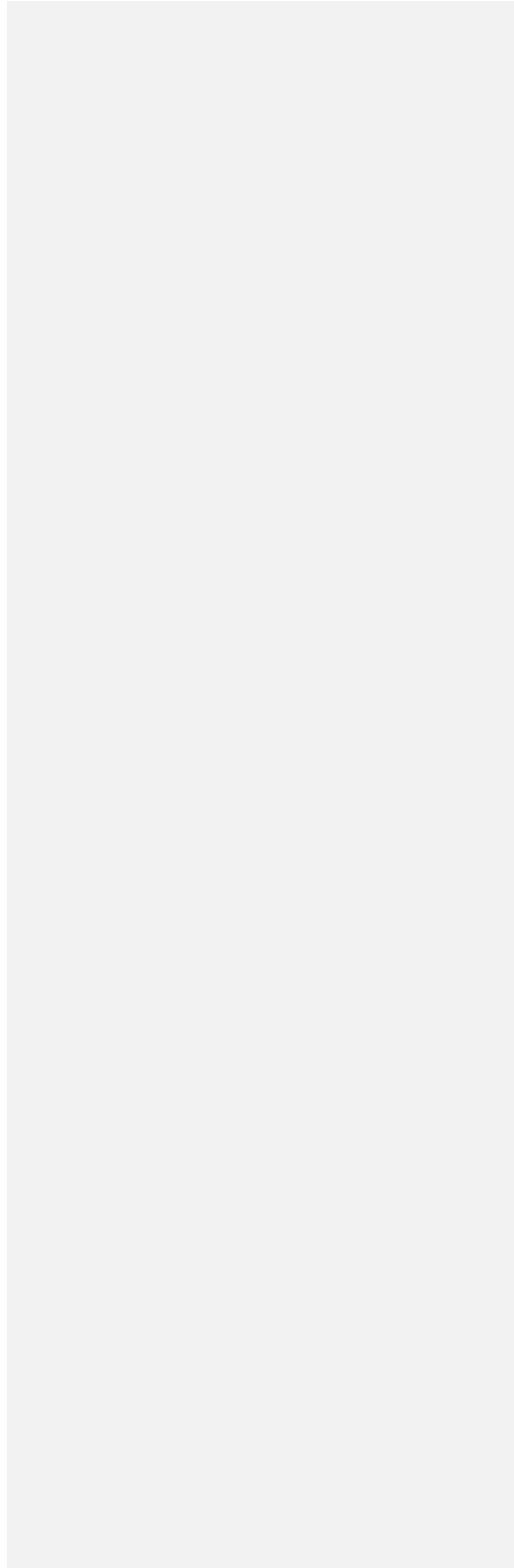

Rev 07-2021



# PVF

## English (US)

Installation and operating instructions.....4

Table of contents



2005 Dr Martin Luther King Jr Street  
Indianapolis, IN 46202



Rev 07-2021

**English (US) Installation and operating instructions****Original installation and operating instructions****Table of contents**

<b>1. General information</b> . . . . .	<b>4</b>	7.1 Maintenance . . . . .	17
1.1 Limited warranty . . . . .	4	7.2 Maintenance schedule . . . . .	17
1.2 Hazard statements . . . . .	5	7.3 Recommended spare parts . . . . .	18
1.3 Notes . . . . .	5	7.4 Consumables . . . . .	18
1.4 Target group . . . . .	5	7.5 Tightening torques . . . . .	18
1.5 General safety warnings . . . . .	5	7.6 Dismantling the pump . . . . .	18
1.6 Material safety data sheet . . . . .	6	7.7 Wear ring . . . . .	19
1.7 Noise level . . . . .	6	7.8 Replacing the wear ring . . . . .	19
<b>2. Product introduction</b> . . . . .	<b>6</b>	7.9 Inspecting the product . . . . .	19
2.1 Product description . . . . .	6	7.10 Repairing the product . . . . .	19
2.2 Features and benefits . . . . .	6	7.11 Assembling the pump . . . . .	19
2.3 System description . . . . .	7	7.12 Accessories . . . . .	20
2.4 Intended use . . . . .	8	<b>8. Storage / handling the product</b> . . . . .	<b>20</b>
<b>3. Identification</b> . . . . .	<b>9</b>	8.1 Storage . . . . .	20
3.1 Nameplate . . . . .	9	8.2 Handling the product . . . . .	21
3.2 Certifications . . . . .	9	8.3 Frost protection . . . . .	21
3.3 Pump size and model . . . . .	9	<b>9. Fault finding / Fault finding the product</b> . . . . .	<b>22</b>
3.4 Type key for in-line fire pump . . . . .	10	9.1 Parts list and sectional drawings . . . . .	24
<b>4. Receiving the product</b> . . . . .	<b>11</b>	<b>10. Disposing of the product</b> . . . . .	<b>24</b>
4.1 Unpacking the product . . . . .	11		
4.2 Transporting the product . . . . .	11		
4.3 Inspecting the product . . . . .	11		
4.4 Scope of delivery . . . . .	11		
4.5 Handling and storing the product after delivery . . . . .	11		
<b>5. Installing the product</b> . . . . .	<b>11</b>		
5.1 Factory support . . . . .	11		
5.2 Location . . . . .	11		
5.3 Foundation . . . . .	12		
5.4 Installation preparations . . . . .	12		
5.5 Mechanical installation . . . . .	13		
5.6 Pipes and connections . . . . .	14		
5.7 Lubrication, priming and cooling systems . . . . .	15		
5.8 Electrical installation . . . . .	15		
5.9 Control, monitoring, and alarm equipment . . . . .	15		
<b>6. Starting up the product</b> . . . . .	<b>15</b>		
6.1 Lubricating the pump . . . . .	15		
6.2 Checking rotation . . . . .	16		
6.3 Check list . . . . .	16		
6.4 Starting up the product . . . . .	16		
<b>7. Service</b> . . . . .	<b>17</b>		



2005 Dr Martin Luther King Jr Street  
Indianapolis, IN 46202



Rev 07-2021

amount paid thereon by purchaser (less depreciation at the rate of 15% per year if purchaser has used equipment for more than thirty [30] days), and canceling any balance still owing on the equipment, or (c) in the case of service, at seller's option, redoing the service, or refunding the purchase order amount of the service or portion thereof upon which such liability is based. These warranties are expressly in lieu of any other warranties, express or implied, and seller specifically disclaims any implied warranty of merchantability or fitness for a particular purpose, and in lieu of any other obligation or liability on the part of the seller whether a claim is based upon negligence, breach of warranty, or any other theory or cause of action. In no event shall seller be liable for any consequential, incidental, indirect, special or punitive damages of any kind. For purposes of this paragraph, the equipment warranted shall not include equipment, parts, and work not manufactured or performed by seller. With respect to such equipment, parts, or work, seller's only obligation shall be to assign to purchaser the warranties provided to seller by the manufacturer or supplier providing such equipment, parts or work. No equipment furnished by seller shall be deemed to be defective by reason of normal wear and tear, failure to resist erosive or corrosive action of any fluid or gas, purchaser's failure to properly store, install, operate, or maintain the equipment in accordance with good industry practices or specific recommendations of seller, including, but not limited to seller's installation and operation manuals, or purchaser's failure to provide complete and accurate information to seller concerning the operational application of the equipment.

### 1.2 Hazard statements

The symbols and hazard statements below may appear in Peerless installation and operating instructions, safety instructions and service instructions.



#### DANGER

Indicates a hazardous situation which, if not avoided, will result in death or serious personal injury.



#### WARNING

Indicates a hazardous situation which, if not avoided, could result in death or serious personal injury.



#### CAUTION

Indicates a hazardous situation which, if not avoided, could result in minor or moderate personal injury. The hazard statements are structured in the following way:



#### SIGNAL WORD

##### Description of the hazard

Consequence of ignoring the warning

- Action to avoid the hazard.



### 1.3 Notes

The symbols and notes below may appear in Peerless installation and operating instructions, safety instructions and service instructions.



Observe these instructions for explosion-proof products.



A blue or gray circle with a white graphical symbol indicates that an action must be taken.



A red or gray circle with a diagonal bar, possibly with a black graphical symbol, indicates that an action must not be taken or must be stopped.



If these instructions are not observed, it may result in malfunction or damage to the equipment.



Tips and advice that make the work easier.

### 1.4 Target group

These installation and operating instructions are intended for professional installers and operators of the product.

We recommend that installation be carried out by skilled persons with technical qualifications required by the specific legislation in force.

### 1.5 General safety warnings



#### WARNING

##### Personnel qualification

Death or serious personal injury

- All operations must be carried out by qualified personnel.



#### DANGER

##### Electric shock

Death or serious personal injury

- The electrical installation must be carried out by a qualified electrician in accordance with local regulations and the manuals provided with the electrical accessories.
- Before starting any work on the product, make sure that the power supply has been switched off and that it cannot be accidentally switched on.
- Never do maintenance work on the pump when it is connected to the power supply.

#### WARNING

##### Automatic startup

Death or serious personal injury

- Before any inspection, maintenance, service or repair of the product, make sure that the motor controls are in the "OFF" position, locked and tagged.
- Pumping equipment, especially fire pumps, can start up at any time. It is imperative to isolate the engine before doing any maintenance work. Switch off the main power supply, remove fuses, secure fuel lines, apply lock-outs where applicable, and affix suitable isolation warning signs to prevent inadvertent reconnection.
- Isolate the fuel supply to the engine before working on any part of the fuel supply or control system.
- Disconnect the batteries by removal of the negative terminal connector.
- Do not place tools on or near the batteries. This could result in a short circuit.
- Inspect all cables for damage or signs of failure and replace immediately if damaged.

English (US)



Commented [IB1]: Floating symbols not assigned



2005 Dr Martin Luther King Jr Street  
Indianapolis, IN 46202

Rev 07-2021

**WARNING****Large openings**

Death or serious personal injury



- If the site is left unattended before the installation is complete, all openings must be covered to prevent entry of children, animals, stones or any other foreign objects.

- Use unbreakable covers that cannot be removed without tools.

**WARNING****Hot surface**

Death or serious personal injury



- Do not allow skin contact with pump components that have heated above 108 °F (42 °C).

- Wear protective gloves when necessary to touch hot surfaces. Surfaces may remain hot after unit has been shut off.

- Ensure that drain water from the stuffing box is cool before contact. The stuffing box on the pump can become hot in the event of a malfunction or maladjustment.

**WARNING****Hot or freezing surfaces**

Death or serious personal injury

- Protect persons from contact with hot or freezing components or auxiliary heating supplies.
- If complete protection is not possible, limit access to maintenance staff only, with clear visual warnings to those entering the immediate area.

**WARNING****Overhead load**

Death or serious personal injury

- Motors which are provided with lifting lugs, lifting ears or eyebolts on the top of the motor should be lifted by these points only. They should be used to lift the entire pump assembly.
- Only lift the entire pump assembly with the lifting lugs provided on top of the motor. Never lift unit using hooks or slings on shafts or conduit box. Straps should not be used to lift a pump assembly.
- When manually lifting pump components, use proper lifting techniques and never bend at the waist. Keep the component close to your body with your back straight, and lift with your legs.

**WARNING****Crushing of hands**

Death or serious personal injury

- Do not work under a suspended object unless you have taken precautions to stop its fall in the event of lifting equipment failure. Do not place hands under a component in such a way that it could fall on your hands if it were dropped.

**WARNING****Sharp and moving machine parts or blades.**

Death or serious personal injury



- Ensure an approved coupling guard is in place before operating the product. Failure to observe this warning could result in injury to operating personnel.

- Wear appropriate protective safety equipment including gloves when handling parts and components.
- Read and follow all recommended guarding and safety instructions for accessories, if any.

**WARNING****Rotating equipment and sharp objects**

Death or serious personal injury



- Do not place fingers, hands, arms, etc. into any opening (such as the air relief valve hole).
- Do not wear loose or frayed clothing or jewelry that could catch on equipment or become trapped in the equipment.

- Do not touch the impeller or other rotating elements, if rotated, this can cause severe injury. Areas of the pump are left open for inspection and adjustment of packing. Never place your hands or fingers into these areas while the equipment is in operation. Do not wear loose clothing, long hair, or jewelry around the equipment.

**WARNING****Excessive noise**

Death or serious personal injury



- If the operating noise level of the product exceeds local code or safe levels (over 85 dBA), the product must be installed in a controlled access area. Provide ear protection to persons authorized to be in this area.
- Fire pumps can start unexpectedly at any time. Ear protection should be carried by, or readily available to, all persons authorized to be in the pump room with these pumps. Observe health and safety regulations limiting exposure of personnel to excessive noise.



Partial decomposition of fluoro-elastomers (when fitted) will occur if equipment reaches temperatures above 400 °F (205 °C).



For applications involving potentially explosive atmospheres, contact Peerless Pumps for more information.



Avoid rapid temperature change in the pumped liquid. Thermal shock from sudden temperature changes can damage pump components.



Pumps are not designed to accept external loads from belt-driven arrangements. A separate jackshaft with a bearing structure suitable for belt loading is required.



Do not remove or paint over any safety labels. If labels are lost or damaged, contact your Peerless Pump representative for replacement.



Do not use gland packing when pumping hazardous liquids.



Do not use the pump as a support for pipes. Do not mount expansion joints, so that their force, due to internal pressure, acts on the pump flange, without written authorization from Peerless Pumps.

**1.6 Material safety data sheet**

As a general practice, material safety data sheets (MSDS) are not supplied with pumps unless required. They may be requested from Peerless Pump.

**1.7 Noise level****WARNING****Excessive noise**

Death or serious personal injury



2005 Dr Martin Luther King Jr Street  
Indianapolis, IN 46202



Rev 07-2021

- If the operating noise level of the product exceeds local code or safe levels (over 85 dBA), the product must be installed in a controlled access area. Provide ear protection to persons authorized to be in this area.
- Fire pumps can start unexpectedly at any time. Ear protection should be carried by, or readily available to, all persons authorized to be in the pump room with these pumps. Observe health and safety regulations limiting exposure of personnel to excessive noise.



## 2. Product introduction

### 2.1 Product description

The Peerless Pump PVF 2000 / 3000 / 4000 Series, Underwriter's Laboratories (U.L.) listed fire pumps, are pre-wired packages that include a full service controller. Every package is mounted on a steel fabricated base with the motor wired to the controller. The casing relief valve, inlet gauge and outlet gauge are mounted on their respective spool pieces. Additional pipes, valves and sensing lines are available with the 3000 and 4000 Series models. The 4000 Series model includes a jockey pump and jockey controller.

### 2.2 Features and benefits

- Capacities up to 750 gpm
- 40 to 165 psi pump pressures
- complete, assembled package with fire pump controller mounted and pre-wired to the pump motor
- all components are U.L. listed
- fast, simple installation
- limited space requirement
- one complete shipment
- no pump couplings for alignment
- no lost or misplaced parts
- established installation costs.

### 2.3 System description

A Peerless Pump factory assembled Package Fire Pump System includes:

- a PVF in-line fire pump with motor, limited or full service,
- U.L. (Underwriter's Laboratories) listed and/ or FM approved fire pump controller,
- fabricated steel baseplate with all accessories furnished for a complete package.

#### 2.3.1 Pump

The pump will be a Peerless Pump model PVF vertical in-line, FM, U.L. listed or U.L.C. (Underwriter's Laboratories of Canada) listed fire pump. The inlet and outlet flanges shall be the same size and shall be displaced 180° with the centerlines on the same horizontal plane. The pump will have a bronze, enclosed impeller, bronze casing wear ring and a bronze shaft sleeve. Shaft sealing will be by a packed-type stuffing box or mechanical seal (U.L.C.) with at least five rings of packing and a lantern ring. The lantern ring will be supplied with water from a tap line connected to the outlet of the pump.

#### 2.3.2 Motor

The motor will be a NEMA JP or JM frame electric induction motor that is close coupled to the pump. The electric motor will have a maximum service factor of 1.15 and the motor locked rotor current will not exceed the limits as stated in NFPA Pamphlet 20. The motor shall bear the U.L. Label for fire pump service.

### 2.3.3 Fire pump controller

The across-the-line automatic electric motor controller shall be specifically designed for limited or full service and will be listed by U.L. and/or FM approved. The controller will comply with all requirements of NFPA Pamphlets 20 and 70. The controller will be capable of interrupting a short circuit at least equal to the available fault current of the supply system. All equipment will be enclosed in a locking NEMA Type 2 drip-proof, gasketed steel enclosure.

### 2.3.4 Packaging

The PVF fire pump package will be complete including the pump with close coupled pump motor, limited service or full service controller pre-wired to the pump motor, 3.5-inch inlet and outlet pressure gauges, flanged outlet spool piece including the outlet pressure gauge, automatic air release valve and casing relief valve. As optional equipment, engineered package systems can include bypass valves and flowmeter lines.

All of the above-mentioned equipment will be mounted by the fire pump manufacturer, pre-wired and pre-piped on a common structural steel fabricated base to provide a self-contained package system.

### 2.3.5 Installation

The contractor will provide a suitable concrete foundation pad. The package will be carefully leveled, secured to the pad and grouted in place. An authorized representative will provide startup service and instruct the owner's representative(s) on the operation and maintenance of the packaged system.

### 2.3.6 Dimensions

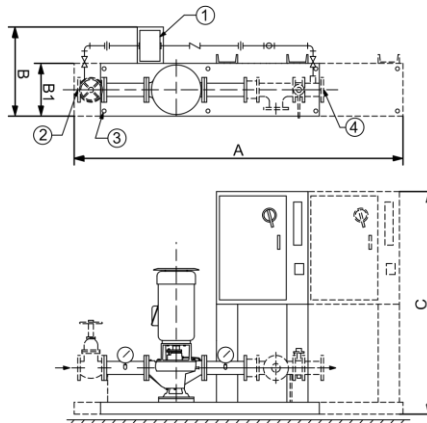

Fig. Dimensional drawing, PVF Series 2000 / 3000 / 4000

Position	Description
1	Jockey pump
2	Inlet
3	6 x ø0.75 in (19.05 mm)
4	Outlet

### Dimensions, 2000 Series models

2005 Dr Martin Luther King Jr Street  
Indianapolis, IN 46202



Rev 07-2021

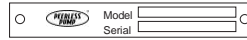

TM060217

Flow	Limited service	Full service
[US gpm (m <sup>3</sup> /h)]	[in (mm)] [ A x B x C ]	[in (mm)] [ A x B x C ]
50 (11.4)	70 x 15 x 82 (1270 x 381 x 2083)	N/A
100-500 (22.7 - 113.6)	70 x 15 x 82 (1270 x 381 x 2083)	96 x 15 x 82 (2438 x 381 x 2083)
750 (170.3)	70 x 15 x 82 (1270 x 381 x 2083)	96 x 15 x 82 (2438 x 381 x 2083)

#### Dimensions, 3000 Series models

Flow	Limited service	Full service
[US gpm (m <sup>3</sup> /h)]	[in (mm)] [ A x B x C ]	[in (mm)] [ A x B x C ]
50 (11.4)	70 x 15 x 82 (1270 x 381 x 2083)	N/A
100 (22.7)	70 x 15 x 82 (1270 x 381 x 2083)	102 x 15 x 82 (2591 x 381 x 2083)
150 (34.1)	76 x 15 x 82 (1931 x 381 x 2083)	102 x 15 x 82 (2591 x 381 x 2083)
200-250 (45.4 - 56.8)	70 x 15 x 82 (1270 x 381 x 2083)	102 x 15 x 82 (2591 x 381 x 2083)
300 (68.1)	76 x 15 x 82 (1931 x 381 x 2083)	102 x 15 x 82 (2591 x 381 x 2083)
400-500 (90.9 - 113.6)	84 x 15 x 82 (2134 x 381 x 2083)	102 x 15 x 82 (2591 x 381 x 2083)
750 (170.3)	84 x 15 x 82 (2134 x 381 x 2083)	102 x 15 x 82 (2591 x 381 x 2083)

### 3. Identification

#### 3.1 Nameplate

Each pump has a nameplate with the pump serial number (see nameplate example). Reference the serial number when contacting Peerless Pump with questions or a service request. A nameplate can also be found on the driver, if supplied. When requesting information about the driver, both the driver serial number and the pump serial number are required. Information on the fire pump nameplate includes the following:

- pump size/model
- pump and motor and controller serial number
- pump manufacturer and location
- certification mark (UL/FM fire or other), if any
- rated flow rate
- rated speed
- rated head

#### Dimensions, 4000 Series models

Flow	Limited service	Full service
[US gpm (m <sup>3</sup> /h)]	[in (mm)] [ A x B x C ]	[in (mm)] [ A x B x C ]
50 (11.4)	84 x 25 x 82 (2134 x 635 x 2083)	N/A
100-150 (22.7- 34.1)	96 x 25 x 82 (2439 x 635 x 2083)	120 x 25 x 82 (2591 x 635 x 2083)
200-250 (45.4 - 56.8)	84 x 25 x 82 (2134 x 635 x 2083)	120 x 25 x 82 (2591 x 635 x 2083)
300-500 (68.1- 113.6)	96 x 25 x 82 (2439 x 635 x 2083)	120 x 25 x 82 (2591 x 635 x 2083)
750 (170.3)	96 x 25 x 82 (2439 x 635 x 2083)	120 x 25 x 82 (2591 x 635 x 2083)

#### 2.4 Intended use

PVF vertical in-line single stage pumps are intended for use in fire protection systems. If there is any doubt as to the suitability of the product for the application intended, contact Peerless Pumps.

- rated psi
- impeller diameter.



2005 Dr Martin Luther King Jr Street  
Indianapolis, IN 46202



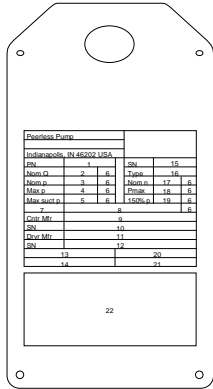

TM000290

Fig. Pump nameplate

Pos.	Description	Pos.	Description
1	Product number	12	Description
2	Nominal flow	13	Description
3	Nominal pressure	14	Serial number
4	Max. pressure	15	Serial number
5	Maximum inlet pressure	16	Pump type/model
6	Unit of measure	17	Tested speed
7	Number of stages	18	Maximum power
8	Impeller diameter	19	Country of origin
9	Controller manufacturer	20	Country of origin
10	Controller serial number	21	Production code
11	Driver manufacturer	22	Marks of approval

**Fig. Flange nameplate**

Information on the flange nameplate includes the following:

- pump size/model
- serial number
- pump manufacturer and location.

**3.2 Certifications**

Industry certifications, for example UL/FM fire, are stated on the pump nameplate. Contact Peerless Pump for additional information.

**3.3 Pump size and model**

The pump size and model are designated with a number, then letter(s), followed by a number, for example 5PVF7.





Rev 07-2021

### 3.4 Type key for in-line fire pump

Example: 8PVF16G 1-A-1/7-P-A-B-R-C

Code	Example	Designation
8	8 inches	Inlet and outlet flange [inch]
PVF	Vertical In-line single stage pump	Pump type
16	16 inches	Maximum impeller diameter [inch]
G	Hydraulic variant	
<>	None (blank)	
A/B/C		Impeller design
...		
...		
1	125 lb, inlet; 125 lb, outlet	
2	125 lb, inlet; 250 lb, outlet	Inlet and outlet flange rating
X	Special	
A	UL listed and FM approved	
B	cFMus approved	
C	UL listed approved	
D	NFPA compliant	Approvals
E	ULC approved	
F	CCC	
X	Special	
1	Cast iron	
2	Ductile iron	Casing material
X	Special	
7	Silicon bronze (ASTM B584)	
9	Nickel-aluminum-bronze (ASTM B148)	Impeller material
X	Special	
P	Packing	
S	Seal component style	Seal
X	Special	
C	Pump + Base + Drive	
D	Pump + Base + Driver + Controller	System configuration
X	Special	
B	USEM / Nidec	
C	General Electric	
D	Marathon	Driver manufacturer
E	WEG	
F	Baldor	
X	Special	
R	Right hand / clockwise	Pump rotation
A	No panel	
C	Firetrol	Controller type





Rev 07-2021

Code	Example	Designation
D	Tornatech	
E	Master	
F	Cutler Hammer	
X	Special	

## 4. Receiving the product

### 4.1 Unpacking the product

Do not unpack more than required to verify that the equipment is complete and undamaged unless installed immediately. Look through all packaging material that is to be discarded to ensure no parts or instructions are discarded accidentally. In some shipments, small boxes containing additional parts are bound to pump skids. Leave small parts in their shipping container until installation. While unpacking, make sure that pump unit accessories are clearly marked indicating the exact pump unit they should be used with.

### 4.2 Transporting the product

The pump has been prepared for shipment at the factory so as to minimize potential damage due to handling and transport.

#### WARNING

##### Crushing hazard



Death or serious personal injury

- Make sure all persons stand clear of the load and the lifting equipment while product is lifted, lowered, loaded and unloaded. Do not allow anyone to stand on, under, or near the load.



Do not subject the pump to excessive g-forces during handling or transport.

### 4.3 Inspecting the product

The product must be inspected after transport and before installation.

To complete the inspection, follow the steps below:

1. Check the product for transport damage. Contact the transporter immediately in case of damage.
2. Check that the delivered products correspond to the order.
3. Check the positions and sizes of fittings. Retighten connections, as they may have become loose during transport.
4. Note the extent of damage or shortage on the freight bill and bill of lading. Failure to note damage or missing parts may result in declined warranty or replacement of parts.
5. Identify and properly store all pump components until ready for installation.

### 4.4 Scope of delivery

A typical shipment will include:

- one skid with the fire pump and the driver mounted on the base plate
- one skid with the controller and accessories, if any
- installation and operating instructions.

Refer to the original order in case of questions about shipping, for example, special arrangements with third-party vendors for shipping and storage.

### 4.5 Handling and storing the product after delivery

Standard factory packaging is suitable for protection during shipment and during covered storage at a job site for a short period

shipment from the factory, depending on the severity of the environment. For international destinations this will vary depending on the seaworthiness of the product's export packaging.

#### Related information

[5.5.1 Raising and lifting](#)

[8.1 Storage](#)

[8.2 Handling the product](#)

### 5. Installing the product

between installation and startup. The preservatives applied at the factory have an effective life of two to three months from the date of

#### 5.1 Factory support

For Engineered to Order (ETO) products, Peerless Pump recommends that you invite a Peerless Pump service engineer to supervise the installation and startup to ensure a proper installation. Peerless Pump recommends that you review the instructions provided with the pump.

#### WARNING

##### Chemical hazard

Death or serious personal injury



- This pump unit is designed to be operated within certain limits pertaining to fluid pump, driver conditions, etc. These limits are listed on the performance curve, or on original contract documentation.
- Do not operate this pump at any pressure, flow rate, or liquid temperature other than those for which the pump was originally purchased. Do not pump any other liquid than the one for which the pump was originally purchased without the consent of Peerless Pump or its authorized representatives. Disregarding this warning can result in pump failure and serious personal injury or death.
- Operation outside of these limits may result in damage to the unit, personal injury, or death. Consult your Peerless Pump representative for approval if a need arises to operate outside of these limits.



Operation at a reduced capacity for prolonged periods may shorten the useful life of the seals or packing, shaft sleeves, bearings, and the shaft. Fire pumps are applied with full knowledge that operation at reduced capacity will occur.

#### 5.2 Location



Locate pump inlet and outlet pipes as well as auxiliary equipment, control and starting panels so as to provide adequate floor space and working room for access and ease of maintenance.



To minimize frictional head loss, locate the pump so that it can be installed with a short and direct outlet pipe and the minimum number of elbows and fittings. If practical, locate the pump that it will be accessible for inspection during operation. Protect pumps, drivers and controls against damage from flooding, freezing, etc.

The inlet supply system must provide the pump with Net Positive Suction Head (NPSH) equal to or greater than that required by the



2005 Dr Martin Luther King Jr Street  
Indianapolis, IN 46202



Rev 07-2021



pump at any capacity on its operating curve. If you need assistance to calculate or measure suction supply system NPSH, contact your Peerless Pump representative.

#### Related information

[5.3.1 Seismic analysis](#)

[5.4.4 Leveling preparations](#)

[5.4.2 Foundation, grout and anchor bolt installation](#)

### 5.3 Foundation

Install the pump on a foundation rigid enough to support the weight of the pump plus the fluid in the pump. Weak foundations or foundations on unstable ground can cause misalignment, vibration, and even foundation failure.



See standard engineering reference manuals for allowable bearing loads of structural steel and floors. Local building codes may recommend allowable bearing loads for different soil types.

The mass of the foundation should be at least five times that of the rotating element of the pumping equipment for a permanent and rigid support for the base plate. Even then, it is possible the foundation mass might not be adequate, so a civil engineer should review and approve the steel support structure before pump installation. Ensure proper foundation and base plate bolt sizing, particularly on high-pressure pumps, to adequately restrain reaction forces such as from directional flow change, system transients and sudden valve closure. Concrete foundations may have anchor bolts installed in sleeves that are two times the diameter of the bolt to allow alignment and should be located by a drawing or template.



Ensure that a civil engineer reviews and approves a steel support structure before pump installation.

Whether the base plate is installed prior to the pump installation or at the same time, the pump must be attached to the base plate. To avoid excessive vibration, ensure the pump feet are clean and free of burrs and nicks. Follow the instructions in this manual for leveling and grouting. After the grout cures (48 hours minimum), the pump unit may be finished for pump installation. We do not recommend installing the base plate without the pump.



Position the foundation and the foundation bolts so that pump inlet and outlet flanges align with the outlet pipes.

#### Related information

[5.4.2 Foundation, grout and anchor bolt installation](#)

#### 5.3.1 Seismic analysis

When the pump is located in a seismically active area or in certain critical installations, ensure that the pumps, supports, and accessories are earthquake-resistant. The design specifications for earthquake resistance vary depending on the geographical area and the class of the equipment. The class of the equipment depends on defining how critical is the survival of the equipment, the characteristics of the structure's response to accelerations, and the foundation supporting the pump.



If a seismic analysis is required, please refer to the governing bodies recommended for grouting and foundation requirements.

The customer must supply complete specifications for earthquake resistance requirements including seismic criteria, acceleration, magnitudes, frequency spectrum, location and direction relative to the pump and qualification procedure.



#### Related information

[5.2 Location](#)

### 5.4 Installation preparations

#### 5.4.1 Pre-installation check

All pump parts are carefully inspected before leaving the factory but may become soiled or damaged in shipping and handling or storage at site. The installer must ensure that all parts are clean and undamaged before installation.



Do not step or walk on the pump components. Do not place other parts or equipment on the pump components.

Use appropriate solvent to wash off any protective coating from the shaft sections and wipe thoroughly clean and dry.

Dirt, sand, etc. in the system will cause premature wear on the critical pump internal surfaces, resulting in reduced pump performance.

#### 5.4.2 Foundation, grout and anchor bolt installation

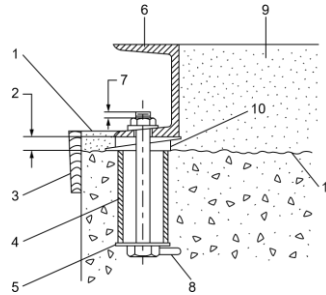

TM054775

Fig. Foundation, grout, and anchor bolt installation

Position	Description
1	Finished grouting
2	0.75-1.25 in (19-32 mm) allowance for grout
3	Formwork
4	Pipe sleeve
5	Washer
6	Base plate
7	0.2-0.4 in (5-10 mm)
8	Lug
9	Grout
10	Wedges or shims left in place
11	Top of foundation

#### Related information

[5.2 Location](#)

[5.3 Foundation](#)

[5.4.5 Grout material](#)

2005 Dr Martin Luther King Jr Street  
Indianapolis, IN 46202



Rev 07-2021

### 5.5.3 Installing grout

#### 5.4.3 Base plate or pump

! Never attempt to lift the pump by means of eyebolts screwed into the driver mounting holes because the bolts are not strong enough to carry the weight of the entire pump.

#### 5.4.4 Leveling preparations

To prevent voids between the surface and the grout, vent flat surfaces that might capture air during grouting

Level the base plate with wedges or with leveling screws supported on rectangular metal blocks.

Coat the leveling screw threads with a non-binding material, such as grease, putty or tape, before grouting to facilitate later removal.

If shims are used, isolate the shims from the initial application of grout. After the initial grout cures, remove the forms and shims and fill the void with a second grout application.

Allow a gap for grouting of 0.75 to 1.5 inches (19.05 to 38.1 mm) between the base plate and the foundation.

#### Related information

##### 5.2 Location

##### 5.5.2 Leveling the pump

#### 5.4.5 Grout material

The grout material that supports the base plate must be carefully selected as it is a critical element of the pump support structure. The product warranty is void if this instruction is not followed.

If the grout cracks or fails, the structure will be compromised. When the alignment is correct, tighten the foundation bolts evenly but not too firmly. Then grout the unit to the foundation. We do not recommend to grout any leveling pieces, shims or wedges in place because this introduces discontinuities and stress concentrations that may cause the grout to crack. Do not fully tighten foundation bolts until the grout cures (usually 48 to 72 hours). Remove jacking screws after the grout cures and fill the holes with an appropriate sealing material.

! Do not distort the base plate by overtightening the foundation bolts.

#### Related information

##### 5.4.2 Foundation, grout and anchor bolt installation

##### 5.5.3 Installing grout

#### 5.4.6 Doweling preparations

Contact Peerless Pump for further information about doweling.

#### 5.4.7 Floor mounting

For an FM approved system, support PVF vertical in-line single stage pumps by a base. Otherwise, the pumps are designed to be supported by the pipes in the system with the motor above the pump.

### 5.5 Mechanical installation

#### 5.5.1 Rigging and lifting

For typical installations, suitable overhead lifting equipment of adequate capacity to lift the driver, the entire pump or the heaviest subassembly of the pump must be available at the job site when installing or removing the pump.

Adequate headroom must be provided to accommodate the pump to be handled plus the rigging.



### WARNING

#### Overhead load



Death or serious personal injury

- Only lift the entire pump assembly with the lifting lugs provided on top of the motor.
- Do NOT lift a PFV unit using slings or straps.

#### Related information

##### 4.5 Handling and storing the product after delivery

##### 8.2 Handling the product

#### 5.5.2 Leveling the pump



Never attempt to align the pump using a spirit (carpenter's) level.

1. Remove the supporting timbers, rope and any other equipment from the top of the foundation.  
If the base plate is not already grouted in place, ensure that the grouting dam around the foundation opening is in place before lowering the pump assembly onto the foundation.
2. Lower the pump unit until the base plate is just above the foundation bolts.
3. Orient the pump so that the inlet and outlet are in the desired direction and the holes in the base align with the foundation bolts.
4. Continue to lower the pump until the bolts begin to enter the holes in the base.
5. If the foundation is concrete, place the wedges under the base plate, adjacent to the bolt holes, one under each of the four sides.
6. For structural foundations (made up of I-beams or H-beams), use shims under the corners.
7. Slowly continue to lower the pump until the bottom of the base plate rests on the wedges or anchor bolts with washers and nuts.
8. Use the wedges or washers and nuts on the anchor bolts to adjust the pump inlet flange center line to the correct elevation.
9. While maintaining the correct elevation, adjust the nuts and washers or shims to achieve the specified levelness of 0.005 inch per foot (0.4 mm per meter) in both directions. Check the levelness with a precision level placed on the machined face of the outlet flange.
10. Place a precision level on the outlet flange. Orient the level parallel with one edge of the base.
11. Move the wedges or add more shims until the level reading is 0.005 inch per foot (0.4 mm per meter).
12. Reorient the level on the same surface, 90 ° from the original position.
13. Again adjust the wedges or shims until the level reading is 0.005 inch (0.12 mm). Take care to avoid upsetting the levelness in the first direction.
14. After each adjustment, check levelness in both directions.
15. Push in or add shims as needed to distribute the weight evenly.
16. Fit nuts on the foundation bolts and tighten them gradually and uniformly.

Rev 07-2021

17. Check the level readings in both directions.
18. If necessary, loosen the foundation bolts and readjust the wedges or shims, tighten the bolts again and check the level readings.

#### Related information

##### 5.4.4 Leveling preparations

##### 5.5.3 Installing grout

After the base plate is at the correct location and leveled with a precision level, grout the base plate to the foundation. Grout compensates for unevenness in the foundation and base plate and minimizes vibrations levels during operations. Also grout prevents the unit from shifting after mounting and alignment.

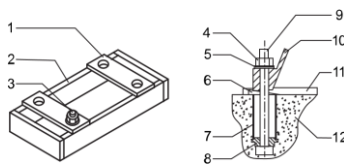

TM075028

Fig. Typical foundation with base plate

Pos.	Description
1	Cross board for holding foundation bolts
2	Template frame
3	Foundation bolt assembly
4	Nut
5	Flat washer
6	Metal wedge
7	Pipe sleeve
8	Maleable washer
9	Foundation bolt
10	Pump base
11	Grout
12	Concrete foundation

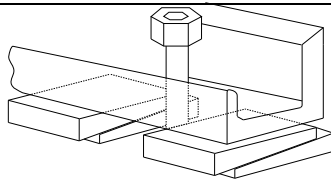

TM060219

Fig. Foundation bolt location, anchorage mount and leveling



2005 Dr Martin Luther King Jr Street  
Indianapolis, IN 46202

Use only non-shrinking grout for grouting the base plate to the foundation. Do not fully tighten the foundation bolts until the grout cures (usually 48 to 72 hours).

1. Prepare the foundation surface according to the grout manufacturer's recommendations.
2. Locate the foundation bolts by the use of a template frame and provide anchorage. See the outline drawings furnished with each pump for the exact location of the foundation bolts.
3. Build a dam on the foundation, enclosing an area around the base plate that includes all alignment wedges. Allow for a grout thickness of 0.75 to 1.50 in (19 to 38 mm).
4. Pour the grout through the holes provided in the base plate or through open ends of steel channel base plates. While pouring, tamp liberally in order to fill all cavities and prevent air pockets. If tamping does not eliminate all air pockets, drill small vent holes through the base surface.
5. Level off the grout to be flush with the top of the dam.
6. Allow the grout to cure (usually 48 to 72 hours) before tightening the foundation bolts or starting the pump. Tighten pipe connections to inlet and outlet flanges.
7. Check the pump alignment.
8. After the grout cures, paint the exposed grout edges to protect the grout from air and moisture.

#### Related information

##### 5.4.5 Grout material

##### 5.4.2 Foundation, grout and anchor bolt installation

#### 5.6 Pipes and connections

##### 5.6.1 Pipe supports, anchors or joints

Inlet and outlet pipes must be anchored, supported and restrained near the pump to avoid application of forces and moments to the pump in excess of those permitted by Peerless Pump.



Do not exceed the forces or moments specified on the outline drawing when connecting pipes to the inlet or outlet flanges.

Consider vibration dampening of the pump to help achieve optimum operation and minimize noise and vibration.



Pipes must be arranged and supported so as to avoid misalignment caused by expansion and contraction due to temperature change

Noise and vibration are generated by the motor, pump and flow in pipes and fittings. Minimizing noise and vibration depends on correct installation and the state of the remaining system.

Eliminating noise and vibrations is best achieved via a concrete foundation, vibration dampers and expansion joints.



Pipes must be cleaned mechanically and chemically and flushed before installing the pump. Many issues with pump packing, seal and seizure are due to improperly cleaned systems.

Before installation inspect the pump internally for foreign matter that may have entered the pump during shipping and storage.

Rev 07-2021

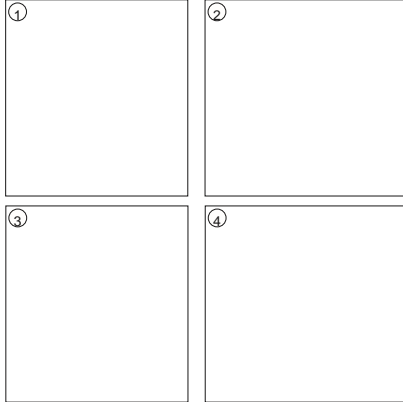

Fig. Pipe arrangements

### 5.6.2 Suction pipes

The inlet and outlet pipes must be of sufficient size and free of internal foreign material.

Considerations for inlet pipes to achieve optimal performance are:

- When operating under inlet pressure, pipe may be equal to, but never less than, the inlet nozzle size.
- Failure of the inlet pipe to deliver the liquid to the pump in this condition can lead to noisy operation, swirling of liquid around the suspended pump assembly, premature bearing failure and cavitation damage to the impeller and inlet portions of the casing.

Contact Peerless Pump for further information.

### 5.6.3 Inlet valves and manifolds

Install isolation valves on the inlet and outlet pipes so that the pump can be isolated for maintenance.

### 5.6.4 Outlet valves

Install a non-return valve and an isolation valve in the outlet pipe. The non-return valve protects the pump from backflow and excessive backpressure. We recommend closing the isolation valve before stopping or starting the pump.

Pump backspin and hydraulic shock can cause severe damage to the pump and motor. To prevent this type of damage, install at least one non-return valve in the outlet pipe, not more than 25 ft (7.5 m) after the outlet flange.

If increasers are used on the outlet side of the pump to increase the size of piping, place them between the non-return valve and the pump.

If expansion joints are used, place them between the pipe anchor and the non-return valve.

### 5.6.5 Nozzle loads

Minimize pump nozzle loads by aligning the pipes with the pump nozzles. Contact Peerless Pump for allowable nozzle load for your particular system design.

### 5.7 Lubrication, priming and cooling systems

If lubrication, priming and cooling systems are supplied, please see additional documents attached to the pump or contact Peerless Pump.



### 5.8 Electrical installation



All electrical connections must be carried out by a qualified electrician in accordance with local regulations.

#### DANGER

##### Electric shock



Death or serious personal injury

- Switch off the power supply before you start any work on the product.
- Make sure that the power supply cannot be switched on accidentally.

Locate the electrical conduit and boxes so as to avoid obstruction of the pump.

Check speed versus torque requirements during the starting phase of a pump against the speed versus torque curve of the driving motor.

In order to accelerate the pump up to rated speed, the driver should be capable of supplying more torque at each speed than required by the pump. In general, this condition is easily attainable with standard induction or synchronous motors, except under certain conditions when a motor with high pull-in torque may be required, such as high specific speed pumps over 5000 US units (100 metric units) or reduced voltage startup.

To achieve a smooth start for the pumping equipment, consider connecting autotransformers to the starting panel or using solidstate starters. These provide a gradual increase in voltage up to rated voltage ensuring even acceleration.

### 5.9 Control, monitoring, and alarm equipment



Check control and alarm systems for correct installation and function according to the manufacturer's instructions.



Check all alarm point settings.

#### 5.9.1 Stopping the unit/reverse runaway speed

A sudden power and/or outlet valve failure during pump operation against a static head will result in a flow reversal, and the pump will operate as a hydraulic turbine in a direction opposite to that of normal pump operation.

If the driver offers little resistance while running backwards, the rotational speed may approach the pump-specific speed.

This condition is called runaway speed and causes mechanical problems. Contact Peerless Pump for recommendations to prevent this condition.

### 6. Starting up the product

#### 6.1 Lubricating the pump

Before attempting to start the pump, check the following items:

- lubrication fitting at packing, if applicable
- lubrication for pump bearing
- lubrication of the driver
- oil-cooling connections for the driver, if applicable

Good practice includes the following:

- Keep lubricant clean, and use a dust-tight cover on the storage container.
- Use the oldest lubricant first.



2005 Dr Martin Luther King Jr Street  
Indianapolis, IN 46202



Rev 07-2021

- Clean the pump lubricant fittings before re-lubricating with grease.
- Use clean dispensing equipment.



Use the proper amount of lubricant. Too much lubricant results in churning, unnecessary power consumption, rapid heating to a high temperature and inadequate lubrication.

Normal bearing temperatures vary with the seasons and environment and may range from 0 to 250 °F (-18 to 121 °C). A continuous rise from the established, normal operating temperature indicates trouble and probable failure of the bearing. Shut down the pump immediately.



**6.1.1 Recommended products**

Follow the driver manufacture's recommendations for lubrication



**6.2 Checking rotation**

**WARNING**

**Electric shock**

Death or serious personal injury

- Switch off the power supply before you start any work on the product.



Three-phase motor shaft rotation can be reversed by switching any two of the three power leads.

Do not attempt to switch any leads in a single-phase motor to change the direction of rotation. The rotation of most single-phase motors is determined by internal wiring and cannot be changed easily.

1. Disconnect the power supply.
2. Lockout-Tagout the power supply.
3. Rotate the motor shaft by hand in both directions. Verify that the motor spins without binding.
4. Momentarily energize the motor. Verify that the motor spins in the direction indicated on the pump volute.

**6.3 Check list**

**6.3.1 Flushing the system**

Before installing the pump, clean the system to remove debris, such as stubs of welding rod, welding slag, and loose scale. Protect the pump and other sensitive parts with startup strainers. Remove the start-up strainers after the flushing cycle has been completed.

**6.3.2 System decontamination**

After the system has been flushed to remove debris, determine if the system needs to be decontaminated. If the system needs to be decontaminated, it must be done before priming and filling the pump.

**6.3.3 Priming**

The pump should not be run unless it is completely filled with liquid, as there is danger of damaging some of the pump components. If the system has suction pressure, follow these steps:

1. Bleed all air from the pump casing and suction pipe by the opening of the automatic relief valve at the top of the pump.

2. Rotate the shaft a few times, if possible, to evacuate any air trapped inside the impeller passages.

**6.3.4 Stuffing box**

The function of a stuffing box is to limit or eliminate leakage of the pumped fluid and to prevent air from entering along the shaft. Pumps are equipped with packing seals. These instructions are intended for pumping units handling water.

**6.3.5 Packed type stuffing box**

A packed type stuffing box must correspond to the suction conditions of the installation. The pump is shipped with the packing installed unless otherwise specified by the customer.

Carefully check the packing, allowing a slight leakage for lubrication. Do not force the packing into a leak-proof position as this will create excessive friction and cause damage to the packing or shaft sleeve.

Maximum packing life can be expected when the leakage approximates a minimum of 40-60 drops per minute. A reduction of leakage reduces the life of both the packing and shaft sleeve. If leakage is excessive, tighten the gland bolts evenly, about 1/6 of a turn at a time. Do not be confused if the leakage seems to increase after an adjustment of the packing has been made. The leakage will normally reduce after a period of time as the packing adjusts itself to its new position.

Keep in mind that it takes time for newly installed packing to "run-in" and that during this initial period, frequent attention and adjustments are necessary. Achieving the desired results will sometimes take several days.



Peerless Pump recommends the use of lantern rings and water seal lines

**6.3.6 Recommended packing**

Recommended stuffing box packing arrangements for use with water:

Inlet pressure range	PTFE graphited synthetic lattice braided Crane C1065 or C1070 / C89835 Bronze	Leakage rate
0 psiG - 100 psiG [0 - 6.9 bar]	PTFE graphited synthetic lattice braided Crane C1065 or C1070 SAE 40 Bronze or Stainless Steel	20 to 50 drops/minute

All UL/ULC/FM listed fire pumps will have water seal piping regardless of the suction pressure.



The stuffing box gland must not be too tight during startup in order to let sufficient liquid lubricate the shaft and the packing.

Once the stuffing box housing and stuffing box gland have reached approximately the same temperature as that of the pump parts, the running-in of the stuffing box gland has been completed. If the stuffing box leaks too much, retighten slightly and evenly while the pump is running. To ensure continuous lubrication, a few drops should always drop from the stuffing box to protect the packing or shaft sleeve against damage, see chart for drop rate recommendations.

When the leakage can no longer be controlled by adjusting the gland, all rings of packing should be replaced. The addition of a single ring to restore gland adjustment is not recommended.



2005 Dr Martin Luther King Jr Street  
Indianapolis, IN 46202





Rev 07-2021

If the pump is to be left idle for a long period of time, we recommend replacing the packing prior to restarting the pump.

## 6.4 Starting up the product

### 6.4.1 Starting the pump

Prior to making an initial start, after installation or major maintenance check the following:

1. Refer to local fire code.
2. Correct installation and rotation of driver.
3. Bearing lubrication on driver.
4. Proper lubrication for stuffing boxes. For pumps having mechanical shaft seals, make certain that the liquid temperature, pressure, cooling and lubrication of seal faces all meet the manufacturer's requirements.
5. Gauges (if used) of correct range and in good condition.
6. All foundation, pump, and driver bolts properly tightened. All external fasteners (nuts, bolts, screws) on pump checked against recommended torque values.
7. When possible, turn the pump shaft by hand to make sure that parts do not bind.
8. Ensure the suction valve is fully open.  
After the pump has run a reasonable time, measure the temperature of bearing and stuffing box housings. The temperature of the stuffing box should approximate that of the pumped liquid. In case of overheating, the packing will become too tight and must be checked.

### 6.4.2 Air in the system

Entrained air reduces pump total head and flow rate. To avoid air in the system, follow these precautions:

- Return lines into tanks should terminate a minimum of two pipe diameters below the low liquid level.

### 6.4.3 Checking the driver lubrication

Before running the drivers either separately or connected to the pump:

1. Follow the driver manufacturer instructions for lubrication requirements.
2. Ensure that the grease-lubricated bearings in the driver have been properly greased with the grade of grease recommended by the driver manufacturer.

### 6.4.4 Driver settings

Refer to the manufacturer's instructions.

### 6.4.5 Pump performance



Initial field test data becomes a valuable baseline for future troubleshooting and maintenance. It may not be possible to match the factory performance due to differences in system resistance.

Once the pump is operating, verify the following:

1. The pipe connections are tight, and no leaks are present.
2. The following attributes match the pump nameplate:
  - a. operating speed
  - b. flow rate
  - c. inlet and outlet pressure
  - d. power input, P1.

### 6.4.6 Before starting the pump

1. Never operate or spin the pump unless it is fully primed. (See "Priming")
2. Turn the shaft by hand to see that it rotates freely.
3. Check that the voltage and frequency on the motor nameplate match the current supply.
4. Be sure the motor is wired for correct voltage.
5. Check that all thermal overload relays are of the proper size and "set" for operation.
6. Be sure the valve in the suction line is open. The discharge valve should be closed.
7. Review the remaining instructions.

### 6.4.7 After starting the pump

#### CAUTION

##### Equipment damage and malfunction

Minor or moderate personal injury



- Overheating will result if pump is operated against a closed valve for more than a few minutes. If closed valve operation is required, install a by-pass line or a small relief valve discharging back to the pump suction. Suction valve should not be used to regulate flow of the pump. Suction valve should be wide open during pump operation and flow is to be regulated by the discharge valve. Failure to adhere to these precautions can result in equipment damage and malfunction.

1. Check the pump rotation with the direction of the arrow on the pump casing. If necessary, change direction.
2. Check the pump for evidence of rubbing or binding which may have been caused by piping strains.
3. Slowly open the discharge valve.
4. See that all pipe connections are tight.

## 7. Service

### 7.1 Maintenance

#### WARNING

##### Electric shock

Death or serious personal injury



- Never do maintenance work when the unit is connected to power.

#### WARNING

##### Crushing hazard

Death or serious personal injury



- Make sure all persons stand clear of the load and the lifting equipment while product is lifted, lowered, loaded and unloaded. Do not allow anyone to stand on, under, or near the load.

### 7.2 Maintenance schedule

To ensure the pumping equipment is operating efficiently, perform frequent inspection and periodic maintenance. An inspection and maintenance log must be maintained and any issues must be reported by the inspector immediately. A suggested guide for preventative maintenance for normal applications is given below.





Rev 07-2021

Unusual applications with abnormal heat, moisture, dust, etc., may require more frequent inspection and service.

Item	Action	Frequency
Packing, packing box	Inspect for excessive leakage	First 150 hours of operation, then every 2000 hours of operation or quarterly
Packing, packing box	Adjust gland and replace packing	As necessary
Vibration	Check for change in vibration	Annually
Bearings	Lubricate (grease)	
	<ul style="list-style-type: none"> <li>Light Duty, approximately 10 hour/week</li> <li>Normal Duty, approximately 8 hour/day</li> <li>Severe Duty, approximately 24 hour/day</li> </ul>	<ul style="list-style-type: none"> <li>Every 2000 hours or at least once a year</li> <li>Every 2000 hours or at least every six months</li> <li>Monthly</li> </ul>
	Fasteners	Check for loose fasteners

### 7.3 Recommended spare parts

The list of recommended spare parts will depend on the following factors:

- supplier lead time
- if the pump is used for normal or severe duty operation, and if a backup pump is available for use.

A suggested list of spare parts for intermittent or no-critical operation:

- stuffing box packing (13)
- set of shaft sleeves (14)
- set of sleeve o-rings (14B)
- set of casing rings (7)
- set of adapter rings
- gasket, casing (73A)
- packing gland
- studs or gland bolts.

### 7.4 Consumables

The following items are normally used in the maintenance of pumping equipment:

- lubricant (grease or oil)
- cleaning materials
- touch-up coating
- hand tools
- measuring equipment (feeler gauges, dial indicator, etc.).



Some items may vary depending on the type of unit.



### 7.5 Tightening torques

Proper tightening of fasteners is very important. The torque values depend on the size and grade of the fasteners used. The values in the table below apply to non-lubricated parts:

Fastener size	Torque
3/8	30 ft-lbs
7/16	50 ft-lbs
1/2	75 ft-lbs
5/8	155 ft-lbs

When assembling a pump, cross-tighten the screws in order to avoid misalignment, binding and leakage. The torque values shown are for clean lubricated threads and gasket joints.

### 7.6 Dismantling the pump

#### WARNING

##### Electric shock

Death or serious personal injury



- Switch off the power supply before you start any work on the product. Starting the motor during pump removal could damage pump and may cause personal injury.



- Drain the pump and isolate pipes before dismantling the pump.

#### WARNING

##### Chemical hazard

Death or serious personal injury



- There may be occasions when a part, such as the impeller, has either been shrunk-fit onto the pump shaft or has become difficult to remove due to products that are corrosive in nature. If you must heat to remove the part, it must be applied with great care. Before applying heat, ensure that any residual hazardous liquids trapped between the two parts are completely drained out to prevent an explosion or emission of toxic vapor. The impeller design varies and so does the amount of heat and the duration of heat applied required to loosen the impeller. Contact Peerless Pump for help with the removal of impellers.

#### DANGER

##### Electric shock

Death or serious personal injury



- Before opening conduit box of electric motor, make sure that the current to the motor is shut off. An electrical shock from contact with live motor leads can be fatal.

Before starting disassembly of the pump, we recommend obtaining a set of spare parts as shown in section 8.2 Recommended spare parts. Peerless Pump does not recommend the reuse of gaskets, O-rings, and packing rings.

#### DANGER

##### Electric shock

Death or serious personal injury



- Disconnect power to the pump driver before starting any repairs.

1. Shut down the pump.

2005 Dr Martin Luther King Jr Street  
Indianapolis, IN 46202



Rev 07-2021

2. Clear a large area adjacent to the pump as a storage space for pump parts as they are dismantled.
3. Open the disconnect switch to cut off power to the motor. Temporarily tie switch open and attach note: DO NOT CLOSE SWITCH - PUMP REPAIR IN PROCESS.
4. Close valves in inlet and outlet lines.
5. Disconnect the motor leads and carefully mark them so they can be reconnected in the exact same order.
6. Remove plug from bottom of casing and drain casing.
7. Disconnect inlet and outlet lines.  
The pump need not be disconnected from inlet and outlet pipes for disassembly.

#### 7.6.1 Dismantling for base mounted pump

If pump is mounted on the base, remove the base hold-down bolts and move pump to bench for disassembly.

1. Remove any seal pipes (tubing) between pump discharge and stuffing box of adapter (Item 11, Figure 1).
2. Remove cap screws holding the adapter (11) to casing (1). Before removing rotating assembly, scribe assembly marks on casing, motor, and adapter flanges so that the unit can be reassembled in the same orientation. Remove complete rotating assembly by lifting motor from casing.
3. Insert a rod of suitable diameter into a passage of impeller (2) and hold while loosening impeller lock screw (26). Remove screw and impeller washer (24A).
4. Slide impeller from end of shaft (6) and remove impeller key (32). If it is necessary to pry the impeller off, use a gear or wheel puller so that force is exerted on the motor shaft and not the motor bearings. Pry evenly on opposite sides of impeller where bending or denting of impeller shrouds will not occur.
5. Loosen the gland bolts (17B) and pull gland (17) out slightly to relax packing (13).
6. Remove screws and slide adapter (11) off from shaft. Use care not to scratch shaft sleeve (14).
7. Remove gland (17), packing (13) and lantern ring (29), if furnished, from the adapter.
8. Slide shaft sleeve (14), O-ring and deflector from shaft.
9. Remove casing ring (7) from casing only if damaged or worn to excess (refer to Repair).

#### 7.7 Wear ring

Wear rings decrease the clearance between the impeller and volute to reduce the quantity of liquid leaking from the high-pressure zone, outlet, and the low-pressure zone, inlet. The rings are designed to use the pumped liquid for lubrication and to be replaced when worn to maintain optimal pump performance and service.

As the rings wear, the clearance between the impeller and the volute increases as does the amount of liquid leaking from the high-pressure to the low-pressure zone. The rate of wear depends on the characteristics of the pumped liquid. The pump will typically have a volute wear ring and can also have an impeller wear ring.

Badly worn wear rings will result in severe degradation of pump performance: head and flow rate, especially on small pumps. Examination of wear patterns can provide valuable information to diagnose pump performance or maintenance issues and determining the source of a problem.

#### 7.8 Replacing the wear ring

Standard pumps are not supplied with impeller wear rings, and they can be installed in the field. The wear surface of the impeller is an integral part of the impeller. Impellers with worn surfaces that cannot be fitted with wear rings must be replaced.

Use the following steps to determine if the wear rings must be replaced:

1. Measure the outer diameter (OD) of the impeller wear surface or wear ring (8) and the inner diameter (ID) of the volute wear ring (7).
2. Compute the diametrical clearance, ID minus OD, and compare them with the allowed diametrical clearance.
3. If the measured clearance is out of tolerance, proceed as follows:



Ensure the ID of the volute ring is concentric with the wear ring OD, and the surface is smooth.

- a. Replace the volute wear ring and impeller wear ring if the measured clearance is two times the maximum allowed clearance.



Machining the impeller wear surface may be necessary to install or replace the impeller wear rings. Ensure that the impeller OD is not reduced and is concentric with the bore of the impeller.

Bronze impeller rings are shrink-fitted onto the hub according to ANSI B4.1 [FN-4].

Hardened impeller rings are installed according to ANSI B4.1 [FN-1].

- b. Replace the volute wear ring if the measured clearance is out of tolerance.

#### 7.9 Inspecting the product

Visually inspect parts for damage affecting serviceability or sealing. Emphasize inspection of mating parts having relative motion wear rings, for example. Perform detail inspection as follows:

1. Check O-rings and bearing cover gaskets for cracks, nicks, or tears; packing rings for excessive compression, fraying or shredding, embedded particles (dirt or metal). Replace if defective in any way.
2. Examine impeller passages for cracks, dents, gouges or embedded material.
3. If the pump capacity falls off due to wear on the impeller and casing ring, repair is made by replacing the casing ring. The inside diameter of the casing ring should be a minimum of 0.015" larger than the impeller skirt diameter.
4. Normally, when the pump is completely disassembled, all gaskets, O-rings and seals should be replaced at reassembly. If the O-ring for the floating seat is not damaged, it may be reused with the other, satisfactory seal parts. Replace all packing rings (13). Replace shaft sleeve (14) if wear has been detected upon inspection.

#### 7.10 Repairing the product

Make necessary repairs in the following manner:

1. If ID on casing rings (7) is grooved, scored or eccentric, replace the casing rings.
2. If impeller wear surfaces are defective.
3. Replace worn shaft sleeve.



Rev 07-2021

**7.11 Assembling the pump**

- ! Avoid damaging any components and avoid contamination (dirt, debris, moisture, etc.) of the unit.

See section "7.5 Tightening torques" for torque values.

Reassemble pump in the following manner:

1. Install deflector and shaft sleeve (14) on shaft. Be sure that sleeve bottoms on shaft shoulder. Position deflector midway between end of sleeve and grease retainer. Align sleeve slot with key slot of shaft.
2. Install deflector (40), shaft sleeve "0" ring (130) and shaft sleeve (14) on shaft. Make sure shaft sleeve bottoms on shaft shoulder. Position deflector on motor shaft about midpoint between gland and motor register within adapter. Align shaft sleeve slot with key slot of shaft, slide gland (17) and lantern ring (29), if furnished, onto the shaft to about the deflector.
3. In the following order, install 3 packing rings (13), the lantern ring (29), if furnished, and 2 packing rings in the adapter cavity. When lantern ring is not furnished, install 6 packing rings. Stagger the joint of each ring approximately 180 from adjacent rings. Be sure each ring is square with the shaft. Move the rings to the bottom of the cavity. When all packing rings are in place, position the gland (17) and loosely seat on packing, using gland bolts (17B). Tighten as required to limit leakage while pump is running.
4. Install impeller key (32) in shaft keyway. Make sure that key enters slot in shaft sleeve. Align impeller (2) with key and install on shaft. Tap impeller hub lightly with plastic hammer to seat against shaft sleeve.
5. Install impeller washer (24A) and impeller lock screw (26). Restrain impeller with rod inserted in one passage and securely tighten screw. Rotate shaft by hand to check for free movement.
6. Lightly coat both sides of casing gasket (73A) with a nonhardening sealing compound, such as grease and graphite. Position on adapter making sure that holes are aligned. Carefully lower complete pump rotating assembly into casing, keeping the impeller properly aligned to prevent binding and possible damage. Make sure the assembly marks match to ensure that proper orientation is maintained. Install screws and tighten uniformly in a star pattern. The cap screws are SAE Grade 5 and must be tightened to the following minimum torque values for dry threads.
7. Install seal piping between pump suction and stuffing box of adapter.
8. Reconnect motor wiring and follow instructions - Pump Operation.  
Materials of construction, specifications, dimensions, design features, and application information, where shown in this instruction manual, are subject to change and/or modification without notice by Peerless Pump at their option.



- ! Make sure that the gland enters the stuffing box at all times so that uniform pressure is exerted around the packing; a tipped gland is an invitation to trouble.
- ! It is very important that specified material and thickness are used for casing gasket. Machined surfaces of both casings must be perfectly clean and free from burrs or nicks.
- ! The stuffing box gland must not be too tight during startup in order to let sufficient liquid lubricate the shaft and the packing.

**7.12 Accessories**

Please see the manuals supplied with the accessories.

**8. Storage / handling the product****8.1 Storage**

Standard factory packaging is suitable for protection during shipment and during covered storage at the jobsite for a short period between installation and startup. The preservatives applied at the factory have an effective life of two to three months from the date of shipment from the factory, depending on the severity of the environment. For international destinations this will vary depending on the seaworthiness of the product's export packaging.

**Related information**

[4.5 Handling and storing the product after delivery](#)

[8.1.1 Controlled storage](#)

[8.1.2 Uncontrolled storage](#)

[8.1.3 Short-term storage](#)

[8.1.4 Long-term storage](#)

[8.1.5 Accessories storage](#)

**8.1.1 Controlled storage**

Maintain storage facility at an even temperature of at least 10 °F (5.5 °C) above the dew point with relative humidity lower than 50 % and with little or no dust. Inspect the equipment weekly to insure all preservatives are intact and internal parts are protected.

Inspect and recoat the equipment periodically with appropriate water displacement rust inhibitors, crusting grease, vapor phase inhibitor or rust preventative coating.

Protect product from flooding or harmful chemical vapors. Ensure that storage is free of excessive ambient vibration which can cause bearing damage. Prevent rodents, snakes, birds or insects from nesting inside the equipment.

**Related information**

[8.1 Storage](#)

**8.1.2 Uncontrolled storage**

For uncontrolled storage periods of three months or less, inspect the equipment weekly to ensure preservatives are intact and internal parts are protected.

**Preparing the product for uncontrolled storage**

- Periodically inspect and recoat the equipment with rust and vapor phase corrosion inhibitors.
- Seal all pipe threads and flanged pipe covers with tape. Place an adequate amount of desiccant near the center of the pump.
- If the pump is assembled, place and securely fasten additional desiccant in the outlet of the pump.
- Cover the equipment with black polyethylene or equivalent, with a minimum thickness of 0.006 in (0.15 mm).

2005 Dr Martin Luther King Jr Street  
Indianapolis, IN 46202





Rev 07-2021



- Provide a ventilation hole approximately the size of a small coin.
- Provide protection from direct exposure to the environment.
- If applicable, connect space heaters on equipment such as motors, engines or controls.

**Related information***8.1 Storage***8.1.3 Short-term storage**

- The pump and equipment, as shipped, have adequate protection for short-term storage for up to three months.
- If the product is not to be installed and operated immediately after receiving it, store it in a clean, dry area at a moderate ambient temperature.
- For packed-type pumps, the packing glands may be left on the pump shaft and securely fastened in position. All exposed machined surfaces should be thoroughly coated with a film of rust preventative material.
- For packed-type pumps, the stuffing box packing must be removed and stored in a sealed plastic bag. Seal the end of the stuffing box with rolled vapor phase inhibitor paper and seal with weatherproof tape.
- Rotate the shaft by hand periodically, at least monthly, to coat the bearing with a lubricant to retard oxidation and corrosion.
- Make sure the pump cannot roll or fall over.
- Follow the motor manufacturer's storage recommendations where applicable.

**Related information***8.1 Storage***8.1.4 Long-term storage**

- Long-term storage protection provided by the factory does not extend the warranty in any manner.
- The warranty is valid only if the equipment is properly handled and stored.
- In case of storage up to six months or longer, the pump must be protected against heat and moisture as described in the previous sections.

**9. Fault finding / Fault finding the product**

If connected directly to electric motors, determine whether or not the motor is direct-on-line and receives full voltage.

Fault	Cause	Remedy
Discharge pressure is too low.	The speed of rotation is too low.	Reestablish the correct speed and direction of rotation.
	The system pressure is lower than anticipated.	Check the system curve.
	There is air or gas in the pumped liquid.	Remove the air from the pumped liquid.
	The wear rings are worn.	Check clearance between wear surfaces.
	The impeller is damaged.	Check that parts are not damaged.



2005 Dr Martin Luther King Jr Street  
Indianapolis, IN 46202

- Periodically, at least monthly, manually rotate the shaft to coat the bearing with a lubricant to retard oxidation and corrosion.
- Ensure that the pump cannot roll or fall over.
- Follow the motor manufacturer's storage recommendations where applicable.
- Inspect the pump before putting it into operation. Make sure that the impeller can rotate freely. Pay special attention to the condition of the shaft seals or the packing and O-rings.

**Related information***8.1 Storage***8.1.5 Accessories storage**

Store accessories according to the manufacturer's instructions.

**Related information***8.1 Storage***8.2 Handling the product**

When storing and handling the product:

- Use properly sized and rated lifting equipment.
- Handle and lift the product according to the local regulations.
- Ensure that point loads do not occur.

**DANGER****Crushing hazard**

Death or serious personal injury

- Place the product on a level surface to prevent overturning.



If the product is equipped with lifting points, use the points during handling.

**Related information***4.5 Handling and storing the product after delivery**5.5.1 Rigging and lifting***8.3 Frost protection**

If the pump is to be used in areas with freezing or frost potential, steps must be taken to prevent freezing and bursting of the pump and cooling systems



	The impeller diameter is too small.	Replace the impeller with one of the correct diameter.
	The direction of rotation is wrong.	Check rotation. Interchange two wires in the power supply.
	The pump has lost its prime.	Re-prime the pump.
	There is insufficient NPSH.	Restore required NPSH.
	Passages are restricted.	Clean the impeller and pump housing passages.
	Joints are leaking.	<ul style="list-style-type: none"> <li>• Tighten the joints.</li> <li>• Tighten the packing.</li> <li>• Check O-ring between sleeve and shaft.</li> <li>• Check gaskets.</li> </ul>
The suction head is insufficient.	The suction line is drawing air.	Tighten the line connections.
	The suction lift is too high, or there is insufficient NPSH.	Reduce the suction lift or restore the required NPSH.
	Air or gas is trapped in the pumped liquid.	Remove the trapped air or gas from liquid.
	The strainer is clogged.	Clean the strainer.
	Poor alignment of the pump. The inlet and outlet pipe clamps are loose.	<ul style="list-style-type: none"> <li>• Reestablish proper alignment of the pump and the motor.</li> <li>• Support the inlet and outlet pipes.</li> <li>• Make sure the vibration dampers, flexible pipes, and conduit connectors are installed correctly.</li> </ul>
	The foundation is cracked.	Repair the foundation.
The noise level has increased.	The ball bearings are worn.	Replace the worn bearings, and renew the lubrication.
	The motor is unbalanced.	<ul style="list-style-type: none"> <li>• Disconnect the motor, and operate it alone.</li> <li>• Remove large pieces of debris, such as wood or rags, from the pump.</li> <li>• Clean out the pump, if necessary.</li> </ul>
	Hydraulic resonance.	<ul style="list-style-type: none"> <li>• Alter the resonant pipes.</li> <li>• Change the pump speed.</li> <li>• Insert a pulsation damper on the pipe system.</li> <li>• Insert a flow straightener.</li> </ul>
Insufficient flow.	The pump is not primed.	Check suction conditions. Prime the pump.

Fault	Cause	Remedy
	The system pressure exceeds the shut-off pressure.	<ul style="list-style-type: none"> <li>• Increase the liquid level on the inlet side.</li> <li>• Open the isolating valve in the inlet pipe.</li> <li>• Check system head curve vs. performance curve.</li> </ul>
	The speed of rotation is too low.	Reestablish the correct speed of rotation.





	The suction lift is too high, or there is insufficient NPSH.	Reduce the suction lift or restore the required NPSH.
	The strainer or the impeller is clogged.	Clean the strainer and the impeller passages.
	Wrong direction of rotation.	Reestablish the correct direction of rotation.
	The joints are leaking.	Tighten the joints.
	The shaft or coupling are broken.	Repair or replace damaged parts.
	The inlet valve is closed.	If the inlet valve is closed, open it slowly.
	There is not enough inlet pressure for hot or volatile liquids.	Reestablish required inlet pressure. Check NPSH.
	The foot valve is too small.	Replace the foot valve.
	Worn or damaged hydraulic parts.	Repair or replace the worn parts.
	Excessive clearance between the wear surfaces.	Repair or replace the wear rings.
The pump loses its prime after starting.	Joints are leaking.	<ul style="list-style-type: none"> <li>• Tighten the joints.</li> <li>• Tighten the packing.</li> <li>• Check o-ring between sleeve and shaft.</li> <li>• Replace the gaskets.</li> </ul>
	The suction lift is too high, or there is insufficient NPSH.	Reduce the suction lift or restore the required NPSH.
Excessive power is required.	The speed of rotation is too high.	Reduce the speed of rotation.
	The pump is operating beyond its recommended performance range.	Set the duty point in accordance with the recommended performance range.
	The specific gravity or viscosity of the pumped liquid is too high.	If less flow is sufficient, reduce the flow on the outlet side, or fit the pump with a more powerful motor.
	The shaft is bent.	Replace the whole rotation element, and possibly the pump.
	The stuffing box is too tight.	Retighten the stuffing box, if possible. Alternatively, repair or replace the stuffing box.
	The impeller clearance is too small causing rubbing or worn wear surfaces.	Adjust the impeller clearance, if possible, or replace the wear ring.
	There is an electrical or mechanical defect in the motor.	Contact your local service center for diagnostics.
	The pump is restricted in its rotation.	Remove any obstacles, or replace any worn parts.
Incorrect lubrication of the motor.	Reestablish correct lubrication of the motor.	



Rev 07-2021

9.1 Parts list and sectional drawings

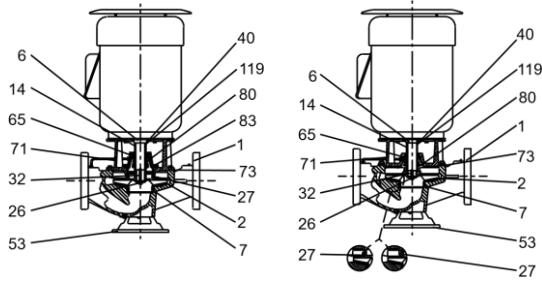

Fig. PVF mechanically sealed sectional drawing

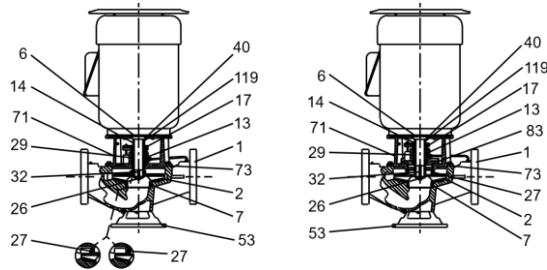

Fig. PVF packing sealed sectional drawing

Item No.	Description	Item No.	Description
1	Casing	29	Ring, lantern
2	Impeller (propeller)	32	Key, impeller
5	Diffuser	40	Deflector
6	Shaft	53	Base
7	Ring, casing	65	Seal, mechanical, stationary element
13	Packing	71	Adapter
14	Sleeve, shaft	73	Gasket
17	Gland	80	Seal, mechanical, rotating element
26	Screw, impeller	83	Stuffing box
27	Ring, stuffing-box cover	119	O-ring

10. Disposing of the product

This product, or parts of it, must be disposed of in an environmentally sound way.

1. Use the public or private waste collection service.
2. If this is not possible, contact the nearest Peerless Pump company or service worksh op.



2005 Dr Martin Luther King Jr Street  
Indianapolis, IN 46202

TM062842

TM062843



Rev 07-2021



<b>98827323</b> 0919
ECM: 12687209

Trademarks displayed in this material, including but not limited to Peerless Pump and the Peerless Pump logo are registered trademarks owned by Peerless Pump. All rights reserved. © 2019 Peerless Pump. All rights reserved.

Peerless Pump | 2005 Dr. Martin Luther King Jr. Street | Indianapolis, IN 46202  
317-925-9661 | [www.peerlesspump.com](http://www.peerlesspump.com)

It is the policy of Peerless Pump to continually seek ways to improve its products and reserve the right to alter documentation without prior notice.