

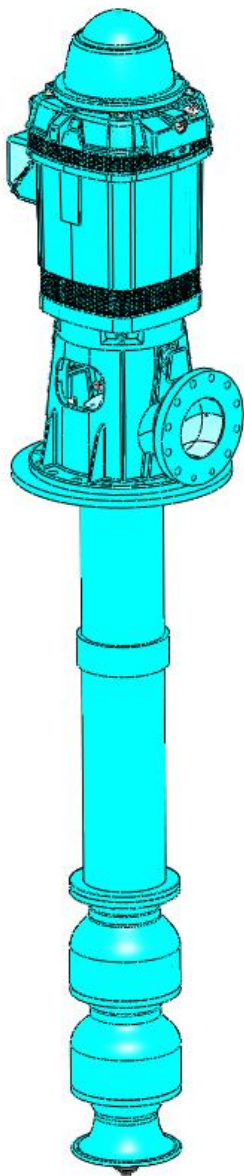

Peerless Pump Company



Vertical Turbine Industrial Pumps Open Line Shaft (OLS)

Installation, Operation and Maintenance Manual

Pump No.: _____
Serial Number: _____
Invoice No.: _____
Item No.: _____
PO. No.: _____



Original installation and operating instructions

Table of Contents

1. Symbols used in this document	2
2. General information	3
2.1 Warranty	3
2.2 Personnel qualification	3
2.3 Warnings	3
2.4 Material safety data sheet	3
2.4.1 Noise level	4
3. Transport and storage	4
3.1 Transport and handling requirements	4
3.2 Receipt and inspection	4
3.3 Rigging and lifting	4
3.4 Storage	5
3.4.1 Controlled storage	5
3.4.2 Uncontrolled storage	5
3.4.3 Standard short-term storage	5
3.4.4 Long-term storage	6
3.4.5 Accessories storage	6
3.5 Disposal of packaging materials	6
4. Identification	6
4.1 Nameplate	6
4.1.1 Certifications	7
4.1.2 Pump	7
4.2 Type key for vertical turbine pump	8
4.3 Type key for vertical turbine fire pump	9
5. Installation	9
5.1 Factory support	9
5.2 Location	10
5.2.1 Checking wells	10
5.2.2 Checking wet pits	10
5.3 Foundation	10
5.3.1 Seismic analysis	11
5.4 Rigging and lifting	11
5.4.1 Leveling	11
5.4.2 Grouting	12
5.5 Installation preparations	12
5.5.1 Inspection	12
5.5.2 Assembling the pump	13
5.5.3 Installing the bowl assembly	13
5.5.4 Installing the column and shaft	14
5.5.5 Installing the bearing retainer	16
5.5.6 Installing the discharge head	16
5.6 Sole plate or pump	17
5.6.1 Leveling	17
5.6.2 Grouting	17
5.7 Piping and connections	17
5.7.1 Pipe supports, anchors or joints	17
5.7.2 Vibration dampers	17
5.7.3 Suction piping	17
5.7.4 Suction valves and manifolds	17
5.7.5 Discharge valves	17
5.7.6 Air and vacuum release valves for wet pit and well pumps	17
5.7.7 Siphons	17
5.7.8 Nozzle loads	18
5.7.9 Non-return valves	18
5.7.10 Strainer	18
5.8 Setting the impeller clearance	19
5.9 Alignment	23
5.9.1 Auxiliary (driver, coupling, etc)	23
5.10 Lubrication, priming and cooling systems	23
5.11 Electrical installation	23
5.12 Control, monitoring and alarm equipment	24
5.12.1 Stopping the unit/reverse runaway speed	24
6. Startup, operation and shutdown	24
6.1 Frost protection	24
6.2 Lubrication	24

6.2.1 Recommended products	24
6.3 Rotation	24
6.4 Guards	24
6.5 Check list	25
6.5.1 System flushing	25
6.5.2 System decontamination	25
6.5.3 Priming	25
6.5.4 Shaft sealing	25
6.6 Startup, operation Sand shutdown	25
6.6.1 Air in system	25
6.6.2 Minimum continuous flow	26
6.6.3 Minimum thermal flow	26
6.6.4 Lubrication system	26
6.6.5 Driver settings	26
6.6.6 Valve settings and operation	26
6.6.7 Parallel and series operation	26
6.6.8 Condition monitoring	27
6.6.9 Vibration	27
6.6.10 Performance testing	27
7. Maintenance	27
7.1 Schedule	27
7.2 Wear rings	27
7.3 Recommended spare parts	27
7.4 Consumables	27
7.5 Required tools and fixtures	27
7.6 Tightening torques	28
7.7 Pump decontamination	28
7.8 Dismantling	28
7.8.1 Wear ring	29
7.9 Assembly	29
7.10 Accessories	30
8. Fault finding (Trouble Shooting)	31
9. Parts list and sectional drawing	32
10. Disposal	32



Warning
Prior to installation, read these installation and operating instructions. Installation and operation must comply with local regulations and accepted codes of good practice.

1. Symbols used in this document



Warning If these safety instructions are not observed, it may result in personal injury.



Warning If these instructions are not observed, it may lead to electric shock with consequent risk of serious personal injury or death.



Warning When pumping hazardous liquids, special attention must be paid to the risk of personal injury.



Warning
The surface of the product may be so hot that it may cause burns or personal injury.



Warning The sound pressure level is so high that hearing protection must be used.



Warning
These instructions must be observed for explosion-proof pumps. It is advisable also to follow these instructions for standard pumps.





Caution

If these safety instructions are not observed, it may result in malfunction or damage to the equipment.

Note

Notes or instructions that make the job easier and ensure safe operation.

2. General information

These instructions should be retained for reference regarding maintenance and operation near the pump. Additional copies can be found at www.peerlesspump.com.

These are general instructions and may not take into account local regulations. The user should ensure such regulations are observed by all parties.

Information in this manual is believed to be reliable. In spite of all the efforts to provide sound and all necessary information, the content of this manual may appear insufficient and is not guaranteed to be complete or accurate in all instances.

2.1 Warranty

This unit is manufactured under a quality management system standard as certified and audited by external quality assurance organizations. Genuine parts and accessories have been designed, tested and incorporated into the products to help ensure their continued product quality and performance in use.

Damage or failure caused by misuse, abuse or failure to follow these instructions are not covered by our warranty.

Any modification of our products or removal of original components may impair the safety of these products in their use.

Standard warranty conditions can be found at www.PeerlessPump.com.

2.2 Personnel qualification

All operations must be carried out by qualified personnel.

2.3 Warnings



Warning
If the site is left unattended before the installation is complete, all openings must be covered to prevent entry of children, animals, stones or any other foreign objects. Use unbreakable covers that cannot be removed without tools.



Warning
When a pump has experienced temperatures over 400 °F (205 °C), skin contact must be avoided with components. Additionally, partial decomposition of fluoro-elastomers (when fitted) will occur.



Warning
Many precision parts have sharp corners and the wearing of appropriate safety gloves and equipment is required when handling these components.



Warning
Hot or freezing components or auxiliary heating supplies can present a danger to

operators and persons entering the immediate area.

Action must be taken to avoid accidental contact. If complete protection is not possible, the machine access must be limited to maintenance staff only, with clear visual warnings and indicators to those entering the immediate area.



Warning
Rapid changes in the liquid temperature can cause thermal shock that can result in damage of pump components and should be avoided.



Warning
When the pump is handling hazardous liquids, care must be taken to avoid exposure to the liquid by appropriate setting of the pump, limiting personnel access and by operator training. If the liquid is flammable and/or explosive, strict safety procedures must be applied.

Gland packing must not be used when pumping hazardous liquids.

Caution

Do not use pump as a support for piping. Do not mount expansion joints, unless allowed by Peerless in writing, so that their force, due to internal pressure, acts on the pump flange.

Caution

Products used in potentially explosive atmospheres. Special consideration must be taken when pumps are installed in these applications. Contact Peerless for more information.



Warning
Use proper lifting techniques when manually lifting components – keep component close to body, back straight, lift with legs.



Warning
Do not remove or paint over any safety labels. If labels are lost or damaged, contact your Peerless Pump representative for replacement.



Warning
Never do maintenance work when the unit is connected to power. Use only qualified electricians for electrical installation and maintenance.



Warning
The surface of the product may be so hot that it may cause burns or personal injury.



Warning
Most surfaces on the driver (engine or motor) can become hot during normal operation.

The stuffing box areas on the pump can





OLS Vertical Turbine Installation, Operation and Maintenance Manual

become hot in the event of a malfunction or maladjustment. These surfaces may remain hot for some time after the unit has been shut down.

Use care when touching these surfaces and wear protective gloves if necessary to touch these surfaces when hot.

Warning
Noise levels, especially for diesel engine driven units, can exceed safe levels. Refer to the noise level published in the accompanying documentation, and, if this noise level exceeds local code or safe levels, place the unit in a controlled access area and provide ear protection to personnel authorized to be in this area.



Warning
Isolate engine (if utilized to drive unit) before any maintenance work is done. Switch off the main supply, remove fuses, secure fuel lines, apply lock-outs where applicable, and affix suitable isolation warning signs to prevent inadvertent re-connection.



ISOLATE the fuel supply to the engine **BEFORE** working on any part of the fuel supply or control system

DISCONNECT the batteries by removal of the **NEGATIVE** terminal connector. Do **NOT** place tools on or near the batteries. This could result in a short circuit. **INSPECT** all cables for damage or signs of failure and replace immediately if damaged.

Warning
Engine fuel fumes are highly flammable! Do **NOT** refuel the engine when it is running or is still hot from recent running.



When refueling, avoid breathing the fuel fumes, particularly if the pump; is installed in an enclosed pump room. Maintain maximum ventilation to clear the fumes quickly.

Do **NOT** start the engine while fuel fumes remain evident or may be present.



Warning
Exhaust gases are hazardous; the exhaust system **MUST** be maintained free from leaks and directed to discharge in a safe area.



Warning
Battery gasses are hazardous and flammable. The battery area **MUST** be well ventilated to clear these gases quickly.



Warning
Do **NOT** store lubricants or other volatile substances near the engine. These should be placed in a designated area having a suitable storage enclosure.

2.4 Material safety data sheet

As a general practice, material safety data sheets (MSDS) are not supplied with pumps unless required. They may be requested from Peerless.

2.4.1 Noise level

Whenever pump noise level exceeds 85 dBA, attention must be given to the prevailing health and safety legislation to limit the exposure of plant operating personnel to the noise. The usual approach is to control exposure time to the noise or to enclose the machine to reduce emitted sound.

Caution

3. Transport and storage

3.1 Transport and handling requirements

The pump has been prepared for shipment at the factory in such a way as to minimize potential damage due to handling and transport.

Caution

The equipment should not be subjected to excessive g-forces during the handling or transport.

3.2 Receipt and inspection

Receiver should report any shortage or damage to the transport company handling the shipment and to Peerless Pump.

Prior to installation, take inventory of the shipment to ensure that the parts received match the list of parts on your order.

Note the extent of damage or shortage on the freight bill and bill of lading. Failure to note damage or missing parts may result in declined warranty or replacement of parts.

Note

If the shaft sections were shipped crated, one end or the top of the crate may be opened for a count. Leave the rest of the crate intact to protect the shaft sections during unloading.

It is important that all the components for a pump unit be identified and properly stored until installation is to be done. There may be many small parts (such as line shaft couplings or hardware) that are best left in their shipping container until installation.

Do not unpack any more than required to verify that the equipment is complete and undamaged unless installation is to be done immediately. Check all packaging material that is to be discarded to verify that no parts or instructions are being accidentally discarded. **In some shipments, small boxes containing additional parts are bound to pump skids.** Leave small parts in their shipping container until installation so they don't get lost. Upon unpacking make certain that accessories with a pump unit are clearly marked showing which pump unit they are to be used with.

3.3 Rigging and lifting

For a pump with an overall length up to 30 feet (9 m) it may be convenient to install the column and shaft sections directly from the transporting vehicle ().

When pumps are received unassembled, all the parts should be located close to the location where the pump will be installed.





Arrange timbers parallel on the ground to support the pump column and shafts.

Caution

Pump parts that are too heavy to be lifted by hand must be lifted from the transporting vehicle with a suitable hoist. Lifting chains or cables must not contact machined surfaces.

Crated shaft sections should be unloaded from the vehicle in the crate and not be uncrated until ready for installation.

Pump parts which are provided with lifting lugs, lifting ears or eyebolts should be lifted by these points only.

Caution

When lifting the entire pump, use the lifting lugs on the discharge head.

Lugs on the driver are only for lifting driver. They cannot be used for lifting the entire pump.

Caution

Column, tube and shaft sections should be handled with extreme care to prevent misalignment and pump malfunction. Shafts are especially sensitive. Bent or dropped shafts should not be used as they are certain to cause pump failure.

Certain extra-long, relatively small-diameter bowl assemblies may be shipped attached to skids bearing a special notation such as:

CAUTION - DO NOT REMOVE THIS PROTECTIVE SKID UNTIL THE BOWL ASSEMBLY IS IN A VERTICAL POSITION, READY TO BE INSTALLED IN THE WELL OR SUMP. RETAIN THIS SKID FOR USE WHEN REMOVING THE BOWL ASSEMBLY FROM THE WELL OR SUMP.

Caution

Remove suction accessory (such as strainer or vortex plate), if installed, from the suction manifold or case prior to lifting the pump assembly. This action will prevent damage to the suction accessory, ensuring the device is not used as a pivot point during lifting. It is very important to observe this precaution when handling these units.



Warning
Do not work under a suspended object unless you have taken precautions to stop its fall in event of sling or hoist failure.

3.4 Storage

Standard factory packaging is suitable for protection during shipment and during covered storage at jobsite for a short period between installation and startup. The preservatives applied at the factory have an effective life of two to three months from date of shipment from factory, depending on the severity of the environment in which the equipment is exposed. For international destination this will vary depending on the seaworthiness of export boxing.

3.4.1 Controlled storage

Storage facilities should be maintained at an even temperature of at least 10 °F (5.5 °C) above the dew point with relative humidity lower than 50 % and little or no dust. The equipment

is to be inspected weekly to ensure that all preservatives are intact and internals are protected.

Inspect and recoat periodically the equipment with water displacement rust inhibitors (VPCI-368-021, Rust-Ban 392 or equal), crusting grease (Rust-Ban 326 or equal), vapor phase inhibitor (Shell VPI-260 or equal) or rust preventative coating (Rust-Ban 373 or equal).

Protect the equipment from flooding or from harmful chemical vapors.

Storage should be free from ambient vibration. Excessive vibration can cause bearing damage.

Caution

Precautions should be taken to prevent rodents, snakes, birds or insect from nesting inside the equipment.

3.4.2 Uncontrolled storage

For uncontrolled storage periods of three months or less, the equipment is to be inspected weekly to ensure that all preservatives are intact and internals are protected.

Inspect and recoat periodically the equipment with water displacement rust inhibitors (Rust-Ban 392 or equal), crusting grease (Rust-Ban 326 or equal), vapor phase inhibitor (Shell VPI-260 or equal) and/or rust preventative coating (Rust-Ban 343 or equal).

All pipe threads and flanged pipe covers are to be sealed with tape. Furthermore you should place 10 pounds (4.5 kg) of moisture-absorbing desiccant or 5 pounds (2.3 kg) of vapor phase inhibitor crystals near the center of pump.

If the pump is assembled, place an additional one pound in the discharge of the pump securely fastened.

Install a moisture indicator near the perimeter of the pump. Cover the equipment with black polyethylene or equal with a minimum thickness of 0.006 (0.15 mm). Provide a small ventilation hole approximately the size of a small coin.

Provide a roof or shed shelter to protect from direct exposure to the elements.

If equipped, connect space heaters on equipment such as motors, engines or controls.

3.4.3 Standard short-term storage

The pump and equipment, as shipped, have adequate protection for short-term (two to three months) storage in a covered, dry and ventilated location at the job site prior to installation.

For packed-type pumps, remove stuffing box packing and place it in a sealed plastic bag. Apply a film of compatible lube oil over the water displacement rust preventative (Rust-Ban 632 or equal). Seal the end of the stuffing box with rolled vapor phase inhibitor paper and seal with weatherproof tape. For packed-type pumps the packing gland may be left on the pump shaft, but should be securely fastened in position.

If mechanical seals are to be used, the annular opening between gland plate and shaft should be closed to exclude airborne dust.





OLS Vertical Turbine Installation, Operation and Maintenance Manual

Additionally, all connections in the seal cartridge must be plugged or sealed.

All exposed machined surfaces should be thoroughly coated with a firm film rust preventative material (Rust-Ban 373 or equal) that is readily removable with a petroleum distillate product.

All exposed painted surfaces should be dry, clean and free of grease and other contaminants.

After pump has been thoroughly drained, cover the pump suction and discharge flanges with a cover (typically cardboard or wood) to blank off these openings.

Rotate pump shaft per the rotation arrow on pump several revolutions at least once per week to coat the bearing with lubricant and to retard oxidation and corrosion, flat spots and staining. Shaft should end up 90° from starting point.

To place the pump in operation, all protective coverings and coatings should be properly removed. For packed-type pumps, repack the stuffing box with the proper number of packing rings from bag. If the packing appears to be damaged or otherwise unfit, it should be replaced.

See section 3.4.4 Long-term storage when the startup of equipment is made over three months from the date of shipment from the factory.

3.4.4 Long-term storage

Long-term storage protection from the factory does not extend the warranty in any manner. Warranty policy is twelve months from startup or eighteen months from time of shipment, whichever occurs first. This warranty is valid only if equipment has been properly handled and stored as per the stated requirements.

Should the equipment be stored or handled improperly, then the warranty is invalid and may be reinstated only after a factory representative is allowed to inspect the equipment prior to startup. Expenses for the representative will be billed in accordance with the latest schedule for field service engineer.

Any repairs or repair parts needed will be billed to the customer at prices in effect at time of shipment of these repairs/parts.

At the time of pump specification and/or order placement Peerless Pump should be advised about the extended storage duration so that special long-term storage protection can be provided for the equipment prior to shipping to the job site.

Inspection of the equipment by a factory representative prior to startup is normally required to ensure equipment integrity and compliance with warranty requirements.

In addition to complying with the standard short-term and storage atmosphere conditions, the following considerations are required:

Dry pump internals and spray the liquid end with a water displacement rust inhibitor (Rust-Ban 392 or equal).

Apply a film of compatible lube oil over the water displacement rust preventative (Rust-Ban 632 or equal).

After pump has been thoroughly drained, cover the pump suction with black polyethylene and discharge flanges with full natural rubber gasket material and blank off these openings

with metal blank flanges and a minimum of four full sized bolts. Cover the pump stuffing box opening with a non-hygroscopic tape.

Cover the equipment with black polyethylene or equal with a minimum thickness of 0.006 (0.15 mm) and seal it with tape. Provide a small ventilation hole approximately the size of a small coin.

The pump should be inspected at regular periods, not to exceed three months.

Rotate the pump shaft per the rotation arrow on the pump several revolutions at least once per week to coat the bearing with lubricant and to retard oxidation and corrosion, flat spots and staining. The shaft should end up 90° from starting point.

To place the pump in operation, all protective coverings and coatings should be properly removed. For packed-type pumps, repack the stuffing box with the proper number of packing rings from bag. If the packing appears to be damaged or otherwise unfit, it should be replaced.

3.4.5 Accessories storage

Store accessories according to the manufacturer's instructions.

Long-term storage should not be undertaken without written understanding from manufacturer.

3.5 Disposal of packaging materials

See section 10. Disposal

4. Identification

4.1 Nameplate

Each pump has a nameplate which list serial number. See fig. 1 and 2. The serial number is needed when contacting Peerless Pump with questions or service request.

When a driver is supplied, there will also be a nameplate on the driver. When requesting information about the driver, both the driver serial number and the pump serial number will be required.

Information on the discharge head nameplate includes the following:

- serial number
- rated flow rate
- rated speed
- rated head
- pump size/model
- pump manufacturer and location.
- certification mark (UL fire or other), if any.

Information of the bowl assembly nameplate includes the following:

- pump size/model
- serial number
- pump manufacturer and location.



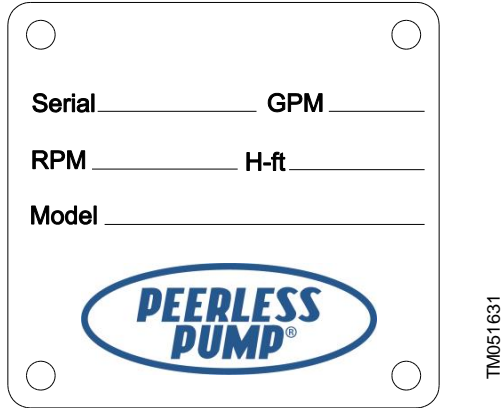

Fig. 1 Nameplate of discharge head

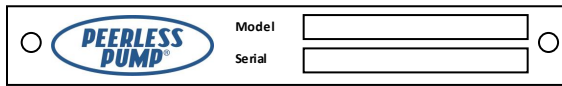

Fig. 2 Nameplate of bowl assembly

4.1.1 Certifications

If the product carries an industry certification (UL fire or other), it will be noted on the pump nameplate. Contact Peerless Pump for additional information.

4.1.2 Pump

The pump size/model is given with a number, letter(s) followed by a number such as 12MB-4. These would represent the nominal bowl diameter or well size the bowl assembly would go into, the pump model and the number of stages.





OLS Vertical Turbine Installation, Operation
and Maintenance Manual

4.2 Type key for vertical turbine pump

Code Example 10HH 12MB-5 L4-O -1/8 -F-8 -1.50-G -P -H

	10HH	12MB	-5	-L4	-O	-1	/8	-F	-8	-1.50	-G	-P	-H
Special First Stage Bowl (if supplied): Bowl Size and Hydraulic Design													
Bowl Size and Hydraulic Design													
Total # of Stages													
Configuration Code													
L1 – Suction Case / Threaded Discharge Bowl													
L2 – Suction Case / Threaded Discharge Case													
L3 – Suction Case / Flanged Column													
L4 – Suction Bell / Threaded Bowl													
L5 – Suction Bell / Threaded Case													
L6 – Suction Bell / Flanged Column													
Shaft Enclosure Type													
O- OLS													
E - ELS													
Bowl/Casing Material													
1 – Cast Iron													
2 – Ductile Iron													
4 – 316LSS													
5 – CD4MCu													
9 – Nickel-Aluminium Bronze													
Z – Special													
Impeller Material													
1 – Cast Iron													
4 – 316LSS													
5 – CD4MCu													
8 – Aluminium Bronze													
9 – Nickel-Aluminium Bronze													
Z – Special													
Column Connection													
T – Threaded													
F – Flanged													
Column Diameter (inches)													
Line Shaft Diameter (inches)													
Head Type													
B – Bowl Only													
S – "S" Type													
C – "C" Type													
G – "G" Type													
U – "UG" Type													
R – "FRA" Type													
A – "FA" Type													
Z – Special													
Type of Sealing													
P – Packing													
S- Seal													
Motor Type													
H – VHS													
S – VSS													
T – Thrust Pod & VSS													
Z – Special													





4.3 Type key for vertical turbine fire pump

Code Example 12MBF-9-L4-UF-1/8-8-O-G-US-F-N

	12MB F	-9	-L4	-UF	-1	/8	-8	-O	-G	-US	-F	-N
Bowl Size and Hydraulic Design												
Total # of Stages												
Configuration Code												
L1 – Suction Case / Threaded Discharge Bowl												
L2 – Suction Case / Threaded Discharge Case												
L3 – Suction Case / Flanged Column												
L4 – Suction Bell / Threaded Bowl												
L5 – Suction Bell / Threaded Case												
L6 – Suction Bell / Flanged Column												
Fire Listing												
UF – UL/FM												
UL – UL Only												
FM – FM Only												
NF – NFPA Compliant												
ZZ - Special												
Bowl/Casing Material												
1 – Cast Iron												
2 – Ductile Iron												
4 – 316LSS												
5 – CD4MCu												
9 – Nickel-Aluminium Bronze												
Z – Special												
Impeller Material												
1 – Cast Iron												
4 – 316LSS												
5 – CD4MCu												
8 – Aluminium Bronze												
9 – Nickel-Aluminium Bronze												
Z – Special												
Column Diameter (inches)												
Shaft Enclosure Type												
O - OLS												
E - ELS												
Head Type												
B – Bowl Only												
S – "S" Type												
C – "C" Type												
G – "G" Type												
U – "UG" Type												
R – "FRA" Type												
A – "FA" Type												
Z – Special												
Driver Type:												
BO - By Other												
US - USEM												
GR - Grundfos												
GE - General Electric												
MA - Marathon												
WE - WEG												
ZZ - Special												
CL - Clarke												
CU - Cummins												
Controller Type:												
N - None By other												
G - Grundfos												
F - Firetrol												
T - Tornatech												
M - Master												
Gear Type:												
N - None By other												
D - DeRan												
A - Amarillo												
R - Randolph												

5. Installation

5.1 Factory support



For customized products, we recommend that you have a Peerless Pump service engineer supervise installation and startup. This is to ensure that the machinery is properly installed. You will then also have the opportunity to review, and see implemented, factory-recommended instructions.



Warning
Do not operate this pump at any pressure, flow rate, or liquid temperature other than those for which the pump was originally purchased. Do not pump any other liquid than the one for which the pump was originally purchased without the consent of Peerless Pump. Disregard of this warning can result in pump failure and serious personal injury or death.

5.2 Location

Locate pump discharge piping (and suction piping when applicable) as well as auxiliary equipment, control and starting panels so that adequate access is provided for maintenance. Adequate floor space and working room should also be provided for maintenance

Note

To minimize frictional head loss, locate the pump so that it can be installed with a short and direct discharge pipe and with the least number of elbows and fittings. If practical, it should be placed so that it will be accessible for inspection during operation. Pumps, drivers and controls should be protected against flooding.

Note

5.2.1 Checking wells

Inspect the well before beginning installations. See fig. 3.

A crooked well may bind and distort the pump column or pump-motor assembly resulting in potential malfunction.

Well straightness should be in accordance with local standards such as AWWA-A100. If straightness is in doubt, the well should be checked prior to installation by lowering a dummy assembly, slightly longer and larger on the diameter than the actual pump or pump-motor assembly, on a cable. This is also important when a stepped well casing is used, with the lower part of the well casing having a smaller inside diameter.

Caution

Wells that have not been properly constructed or developed, or which produce sand, can be detrimental to a pump. If a well is suspected of producing an excessive amount of sand, a unit other than the production pump should be used to clear the well.

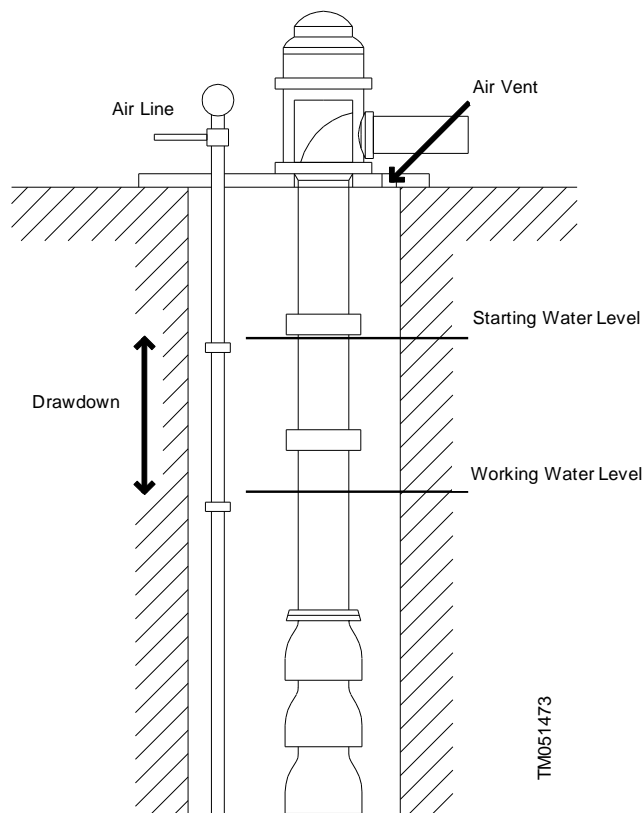

Fig. 3 Typical deep well installation

5.2.2 Checking wet pits

The configuration of the intake structure should be in accordance with industrial standards, such as HI 9.8, Pump Intake Design.

Dimensional checks should be made as follows to prevent installation and servicing problems.

1. Length of pump versus depth of sump.
2. Correct fit of anchor bolts sole plate (if supplied) or discharge head. If sole plate is supplied, check fit of holes from sole plate to discharge head.
3. Satisfactory angular location of anchor bolts or correct alignment of discharge head to discharge piping.
4. Proper conduit location provided for driver.
5. Sufficient head room for handling.

5.3 Foundation

The pump must be installed on a foundation rigid enough to support the entire weight of the pump plus the weight of the fluid contained in it. Weak foundations or foundations on unstable ground can cause misalignment, vibration, and even total foundation failure.

The mass of the foundation should be sufficient, preferably five times that of the rotating element of the pumping equipment, to form a permanent and rigid support for the base plate or discharge head. This is equally important whether the pump is installed over a pit, over a well or into a suction barrel.



Foundation and base plate bolt sizing is critical, particularly on high-pressure pumps, to adequately restrain reaction forces such as from directional flow change, system transients and sudden valve closure. Concrete foundations may have anchor bolts installed in sleeves that are two times the diameter of the bolt to allow alignment and should be located by a drawing or template.

Caution Steel support structures may not be stiff enough even if their mass exceeds five times that of the rotating element. A civil engineer should review and approve a steel support structure before pump installation.

A barrier or frame (dam) to retain the grout between the pump base and the foundation must be provided around the hole for the pump column.

Some pumps are provided with a sole plate or suction barrel that fits between the discharge head and the foundation. In this case, the foundation bolts must align with the holes in the sole plate or suction barrel rather than those in the discharge head. The sole plate is normally installed with the pump, but can be installed before the pump.

Whether the sole plate is installed prior to the pump installation or at the same time, the discharge head must be attached to the sole plate. Check that the bottom of the discharge head has been machined over its entire surface and is clean and free of burrs and nicks. **The machined surface of the base plate is installed against the machined surface of the discharge head.**

Failure to have each component's surface machined will result in excessive vibration.

Follow the instructions in sections 5.4.1 Leveling and 5.4.2 Grouting. After the grout is cured (a minimum of 48 hours), the discharge head may be removed to start the pump installation. Peerless Pump does not recommend installation of the sole plate without the discharge head. If, however, there is no choice except to install the sole plate alone, use the machined surface at the top of the sole plate (the discharge mounting surface) for leveling.

Caution Position the foundation and the foundation bolts so that the discharge head will be in accurate alignment with the discharge piping.

5.3.1 Seismic analysis

When pumps are located in seismically active areas and for certain critical installations the pumps, supports and accessories should be earthquake-resistant. The design specifications to achieve earthquake resistance vary, depending upon geographical area, class of the equipment (defining how critical the survival of the equipment is) and the characteristics (acceleration response) of the structure or foundation supporting the pump.

Complete specifications for earthquake-resistance requirements should be supplied by the customer. This includes the following:

- the seismic criteria, such as acceleration, magnitudes, frequency spectrum, location and direction relative to pump
- the qualification procedure required, i.e., analysis, testing or a combination of these, and requirements for operability during and/or after test.

5.4 Rigging and lifting

For typical installations, suitable overhead lifting equipment of adequate capacity to lift the driver, the entire pump (without driver) or the heaviest subassembly of the pump should be available at the job site when installing or removing the pump.

Adequate headroom should be provided to accommodate the longest section of the pump to be handled, including rigging.

Properly sized and rated slings, chains and shackles should be available for attaching to the lifting lugs (eyes). Rated eyebolts are required for handling pump sections when lifting lugs are not provided.

Caution I-beams or column clamps for supporting pump subassemblies at the foundation should be available when it is necessary to install the pump in sections. Common tools are used for this type of work, including a machinist level to ensure proper leveling of the foundation plate.

5.4.1 Leveling

1. Remove the supporting timbers, rope and any other equipment from the top of the foundation.
2. Cover the discharge head to protect it from dust, and sweep the foundation clean.

Note If the sole plate is not already grouted in place, be certain that the grouting dam around the foundation opening is in place before lowering the pump assembly onto the foundation.

3. Lower the pump until the base of the discharge head or sole plate, if used, is just above the foundation bolts.
4. Orient the pump so that the discharge outlet is in the desired direction and the holes in the base align with the foundation bolts.
5. Continue to lower the discharge head or pump until the bolts just enter the holes in the base.
6. If the foundation is concrete, place the wedges (furnished with the pump) under the sole plate, if provided, or discharge head or , adjacent to the bolt holes, one under each of the four sides.
- For structural foundations (made up of I-beams or H-beams), use shims under the corners.
7. Continue to slowly lower the pump until the base of the discharge head or sole plate rests on the shims or anchor bolts with washers and nuts.

Caution Accurate alignment of the discharge head in relation to the pump shaft is absolutely essential for smooth and trouble-free operation.

8. Level the discharge head or sole plate, if used, by using the wedges or washers and nuts on the anchor bolts, adjust the discharge head flange centre line to the correct elevation.
9. While maintaining the correct elevation, adjust the nuts and washers or shims to achieve the specified levelness of 0.005" per foot (0.4 mm per meter) in both directions as shown in fig. 4. The levelness should be measured by placing a precision level on the machined face of the discharge head motor register.



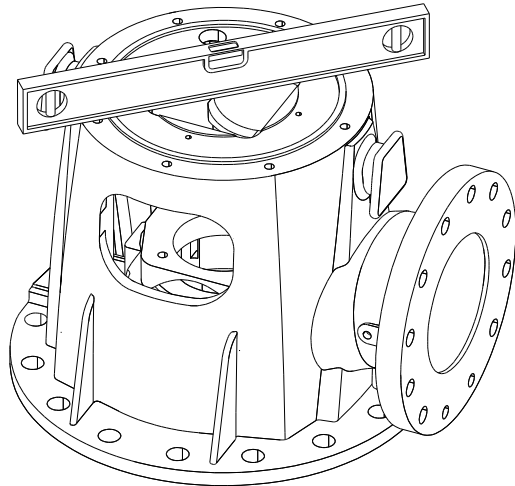

TM051622

Fig. 4 Check for levelness in two directions

Caution

Never attempt to align the discharge head of a well pump using a spirit (carpenter's) level. If the pump column does not hang freely in the well, as might be the case when the well is drilled at a slight slant, leveling the discharge head will not ensure the necessary shaft alignment and clearance in the driver spindle. The discharge head base must be square with the pump shaft regardless of the result indicated by a spirit level. A bent shaft could occur, causing early pump failure and expensive repair.

10. For other applications, place a machinist's level on the driver mounting surface of the discharge head.
11. Move the wedges or add more shims until the level reading reaches 0.005" per foot (0.4 mm per meter).
12. Reorient the level on the same surface, 90° from the original position.
13. Again adjust the wedges or shims until a 0.005" (0.12 mm) level reading is reached, taking care not to upset the levelness in the first direction.
14. After each adjustment, check for levelness in both directions.
15. Push in or add to any loose shims to distribute the weight evenly.
16. Fit nuts on the foundation bolts and tighten them gradually and uniformly.
17. Check the level readings in both directions.
18. If necessary, loosen the foundation bolts and readjust the wedges or shims, tighten the bolts again and check the level readings.

5.4.2 Grouting

After the discharge head is at the correct location and leveled with a precision level, the discharge head and/or sole plate need to be grouted to the foundation.

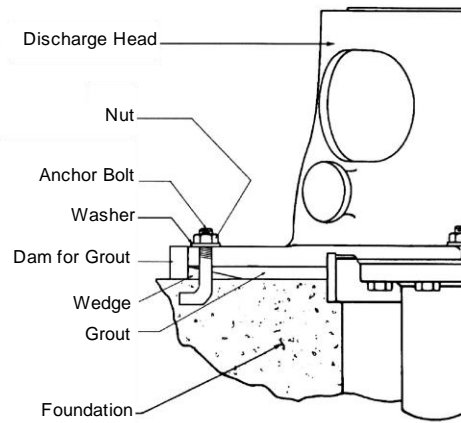

TM051615

Fig. 5 Typical foundation without sole plate

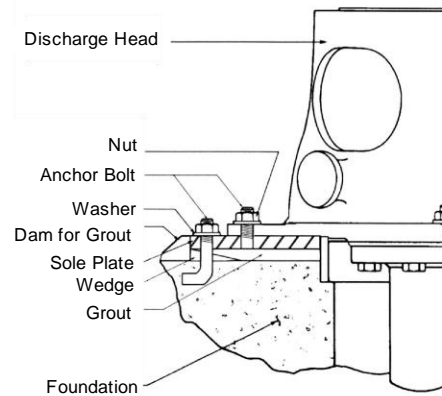

TM051616

Fig. 6 Typical foundation with sole plate

Use only non-shrinking grouting material for grouting the discharge head, sole plate or suction barrel to the foundation

1. Build a dam on the foundation, enclosing an area around the discharge head that includes all alignment wedges. The top of the dam should be approximately 1/2 inch (12 mm) above the bottom of the discharge head base. See fig. 5 and 2.
2. Pour the grouting material into the dammed-in area and force it between the discharge head and the foundation all around.
3. Level off the grout flush with the top of the dam.
4. Allow the grout to cure at least 48 hours before tightening the foundation bolts or starting the pump.

5.5 Installation preparations

5.5.1 Inspection

All pump parts were carefully inspected before leaving the factory, but may have become soiled or damaged in shipping and handling or storage at site. The installer must therefore check that all parts are clean and undamaged before installing them.

Caution Do not step or walk on the shafts. Do not place other parts or equipment on the shafts.



Warning
Do not work under a suspended object unless you have taken precautions to stop its fall in event of sling or hoist failure.

Use appropriate solvent to wash off any protective coating from the shaft sections and wipe thoroughly clean and dry. Clean the shaft coupling threads using a wire brush and solvent, cover both ends, and store couplings in a clean place until ready for use.

Unless the pump is less than 30 feet (9 m) and was shipped from the factory pre-assembled, all installation and assembly must be done vertically. If the unit was shipped assembled from the factory, check all pump, and column joints for tightness with the pump in the vertical position and with its weight borne by support clamps around the well or sump opening.

Caution
Do not attempt to assemble the bowl, column, shaft and discharge head horizontally on the ground. This could cause bending and damage the shaft sections, tubing (if applicable) and possibly the column pipe and lead to malfunction of the pump

The well or sump must be thoroughly cleaned of dirt, debris and contaminants before installing the pump. After the installation, the well or sump should again be inspected for foreign matter and cleaned, if necessary. If it is suspected that the fluid will contain sizable solid particles or that foreign objects may enter the sump or well, a suction strainer should be installed with the pump and cleaned periodically. Your Peerless Pump dealer will be glad to advise you on the need for a suction strainer. Dirt, sand, etc. in the sump or well will cause premature wear on the critical pump internal surfaces, resulting in reduced pump performance.

Check that shaft sections are straight and have not been bent in shipping or handling.

1. Set a pair of rollers or V-blocks on a firm base next to the pump site to support one shaft section. See fig. 7.
2. Provide a solid mounting for a dial indicator at points 1, 2 and 3.
3. Place a shaft on the rollers or V-blocks and rotate it slowly by hand while checking the eccentricity (runout) at points 1, 2 and 3. It should not exceed 0.005 inches (0.12 mm).

4. Check all shaft sections in this manner. Do not use any given. Shafts that do not

Update chart to be the 5 and 10' with different runouts at different sections. New chart?

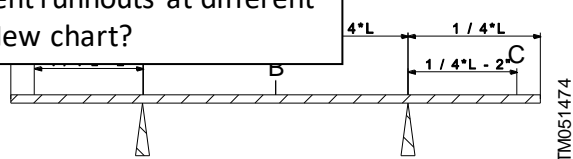

Fig. 7 Checking the shaft straightness

The shaft may be re-straightened by either the heating and cooling technique or bending it back to straight by use of a press. All re-straightened shaft sections must have a clean up cut machined on both ends perpendicular to the axis of the shaft and must be checked for eccentricity.

Larger shafts and shafts for non-threaded (split-ring) couplings may have an internal threaded lifting hole on one end; this end goes up.

In a flanged column pump, the intermediate column sections have identical ends; either end may be upward. However, the top and bottom sections may not have identical ends. See the assembly drawing for the proper orientation. If the flanged column has an integral bearing retainer, that end faces upward.

Note
If the pump was received assembled, bolts should be checked to verify they did not loosen up during transit. Retorque bolts per Section 7.6 where necessary.

5.5.2 Assembling the pump

The preferred method is to install the shaft and couple it, then install the column over the shaft, provided that head room permits.

Caution
When inserting the shaft sections into the column section, take care not to bend the shaft or damage the threads.

1. Check the total length of the bowl assembly, suction pipe (if used) and strainer (if any) to see whether the hoist clearance is sufficient to handle these parts as a unit. If the clearance is sufficient, fit the suction pipe to the bowl assembly. Do not install strainer at this time. Lay this assembly across the timbers, close to the sump, ready for installation.

If head room is limited, pre-assemble all the standard shaft and column sections. Alternatively the unit may be assembled over the well. Do not insert the top shaft section into the top column section at this time.

2. Before proceeding with the actual installation, check to see that all the pump parts and equipment have been prepared according to the directions given in this section.

5.5.3 Installing the bowl assembly

1. Place two rated eyebolts diametrically opposite in the upper flange of the bowl assembly.
2. Attach a sling to the eyebolts using suitable shackles and pass the looped end of the sling over the hoist hook.
3. Lift the bowl assembly in such a way so that it is not dragged or bumped in order to prevent damage to any part of the pump.
4. While the bowl is in the vertical position, install the strainer, if provided.
5. Fasten a box-type clamp to the bowl assembly, just below the upper flange. See fig. 8.

Caution
Never attempt to handle or lift the bowl assembly by the shaft protruding from the upper end. This could result in bending of the shaft.

6. Lower the bowl assembly until it rests securely on the support beams of the clamp. See fig. 8.



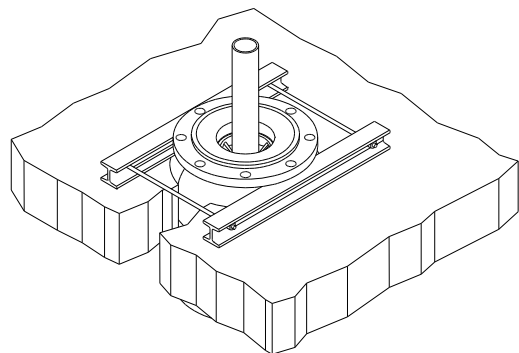

TM0511618

Fig. 8 Bowl assembly supported by a box-type clamp

7. Place over the top of the bowl assembly a specially made wood or metal apron that covers the opening and fits closely around the impeller shaft. Wrap a clean rag tightly around the shaft, over the apron. This will prevent entry of foreign matter into the bowl assembly.

Caution

Take care not to drop tools, screws, nuts or any other foreign objects into the bowl assembly or sump. Such an object could impair pump performance or ruin the impellers. If passed by the pump into the discharge piping, a solid object could cause serious damage to downstream components.

Any foreign object dropped into the pump column must be retrieved before proceeding with the pump installation. If any foreign object is dropped into the sump, it must be retrieved prior to starting the pump.

5.5.4 Installing the column and shaft

1. Head room permitting, lift the appropriate length shaft into a vertical position. Check shaft threads for any foreign materials or damage, and clean threads with a wire brush and solvent as required. For longer multi-section pumps, deep set pumps, or pump installations with inadequate head room; shafting can be assembled into sub-assemblies prior to installing into the sump. The column pipe and shafting must be hung and assembled together. This method will reduce the vertical installation height and steps.

Caution

When installing shafting and column sections together ensure all pieces are secured and beware of shafting and column pipes sliding, ramping, or falling from hung assembly.

For Threaded Coupling

Caution

Shaft threads are left-hand and must be clean and deburred.

2. Coat the shaft threads with anti-seize compound.
3. Check the shaft coupling for any damage or foreign material and clean, if necessary.
4. Screw the coupling onto the lower shaft for half its distance. For correct positioning of the coupling on the shaft is to insert a fine wire into the drilled hole in the center of the coupling.
5. Visually inspect the shaft threads and face of the mating shaft. Coat the shaft threads with anti-seize compound.
6. Lower the shaft into the coupling.
7. Manually screw upper shaft until tight. If resistance is encountered, remove the coupling and shaft, and inspect the threads at both the coupling and shaft to determine the

problem. Because the threads of the shaft and coupling are straight (not tapered), one should be able to tighten them by hand until the two faces mate in the center of the coupling.

8. Check the tightness of the mating by using two pipe wrenches as shown in fig. 9 to verify the shaft ends butt together. Excessive force should not be used in this connection.

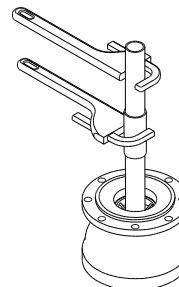

TM051475

Fig. 9 Making a shaft joint

For Bolted Keyed Coupling

1. Clean the upper portion of the shaft (the area which will engage the shaft coupling) and lubricate it with anti-seize compound. Slide a coupling cap over the shaft, larger ID upward, letting it rest on the sand collar or the deflector cone or diffuser cone.
2. Insert the key into the key-seat of the shaft.

Caution

Be certain that the coupling body and shaft are properly aligned before permitting them to engage. Improper engagement will result in galling of the metal making assembly of these parts impossible.

3. Check that the coupling body slides without significant resistance over both shaft ends that it will be joining. Install the coupling body over the shaft and install split rings and cap.
4. Fasten the lower coupling cap to the coupling body, using the cap screws provided. Tighten the screws gradually and uniformly to values in Table 7.6 using blue Loctite 242.
5. Clean the lower portion of the mating shaft (the area which will engage the coupling) and lubricate it with anti-seize. Slide the upper coupling cap over the mating shaft, large ID downward, above the split ring groove. Install a split ring in the groove, and slide the coupling cap down to capture the ring. If there is a separate key for the shaft, install it in the shaft at this time. Carefully lower the shaft, guiding the lower end of the shaft into the coupling body until the split ring rests on the body.
6. Fasten the upper coupling cap to the coupling body, using the cap screws provided. Tighten the screws gradually and uniformly to values in Table 7.6 using blue Loctite 242.

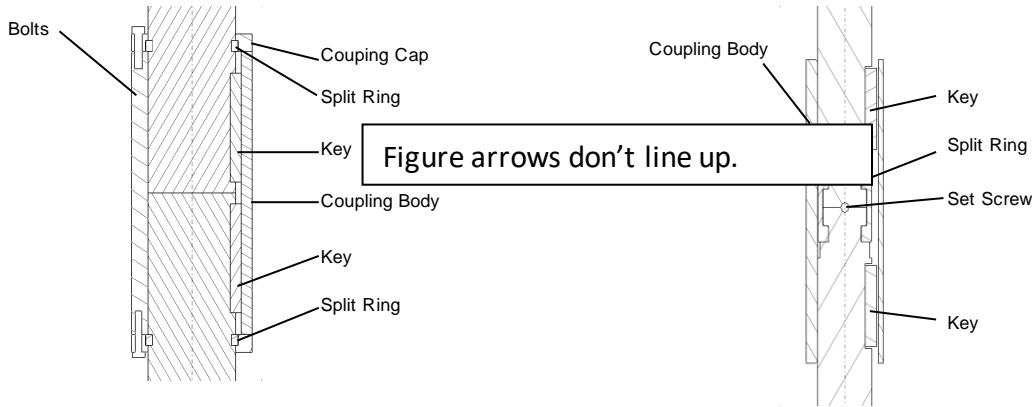

Fig. 10 Bolted Keyed Coupling assembly

Fig. 11 M-Style Keyed Coupling assembly

For M-Style Keyed Coupling

1. Check that the coupling body slides without significant resistance over both shaft ends that it will be joining. Slide the coupling body over the lower shaft. Allow the coupling to rest on the bowl bearing or sand collar.
2. Insert the keys into the key-seats of the shafting.

Caution

Be certain that the coupling body and shaft are properly aligned before permitting them to engage. Improper engagement will result in galling of the metal making assembly of these parts impossible.

3. Align the shafting and keyways with the mating shaft with the shaft ends nearly butting together. Install a split ring into both the line shaft and mating shaft grooves. Check that the keys are positioned in the axial direction evenly from the top and bottom to insure proper coupling position.
4. Mark the shaft to indicate the end of the coupling when it is centered between shafts. Holding the split ring together, slide the coupling body upwards over the split ring until it is centered between shafts.
5. Coat the set screws with Loctite 242 and then tighten the set screws on the side of the coupling body to hold the coupling in place. The set screws must engage the center of the split ring.

Installing the Column

1. Connect a dragline to the lower end of the column flange, to be used in guiding and aligning the column over the shaft. See fig. 12. The use of the dragline will prevent accidental bumping of the shaft by the column that could bend the shaft.
2. If gaskets or O-rings are used between the flange joint, fit the appropriate gasket/O-ring on the bowl flange.
3. If the column pipe is threaded and coupled, the threads should be thoroughly cleaned and coated with non-hardening thread sealant. With column supported, start the threads by hand to be sure there is no cross-threading occurs. Then completely tighten the pipe against the discharge bowl using a chain wrench.
4. For flanged column, lower the column onto the bowl flange.. Check that the two flanges are properly registered and cross-tighten fasteners to the torque in Table 7.6..

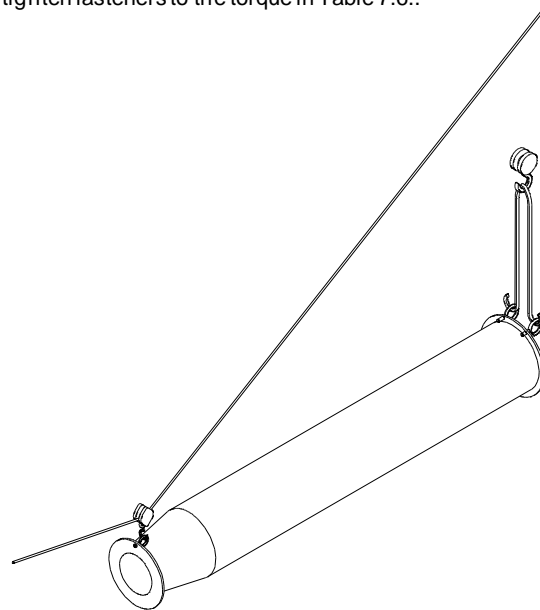

Fig. 12 Column section with dragline attached

TM051477

5.5.5 Installing the bearing retainer

Note Keep rubber bearings free of any lubricant or sealing compound.

1. If using a flanged column, place the rim of the bearing retainer into the counter bore in the column flange. See fig. 13. Columns 18" and larger typically use a welded in retainer.
2. Slide the bearing retainer assembly over the protruding shaft section.
3. Fit a column flange O-ring or gasket.
4. If the pump has only one column section, continue the installation procedure as described in section 5.5.6 installing the discharge head.

If the pump has additional column sections, proceed with the following instructions.

5. Fit a removable shaft sleeve, if supplied, over the shaft and into the bearing bore. The sleeve should be centered axially in the bearing.
6. Tighten the sleeve set screws. Apply a seizing compound, such as Loctite 242, on the set screw threads to prevent loosening of screw.

Additional column sections

1. Fit the bearing retainer with bearing over the extending shaft and on to the female register of the column flange.
2. Fit the O-ring over the bearing retainer resting in the chamfered part of the lower column flange.
3. Install the remaining shaft and column sections, including the top sections, bearing retainers and removable sleeves, if applicable.
4. Install the head shaft in the top column section.
5. When the column section has been bolted into place, replace the box clamp under the newly made flange joint and allow the unit to rest on the clamp.
6. Do not lower the top column section into the sump yet, to facilitate installation of the discharge head.
7. Remove eyebolts and sling.

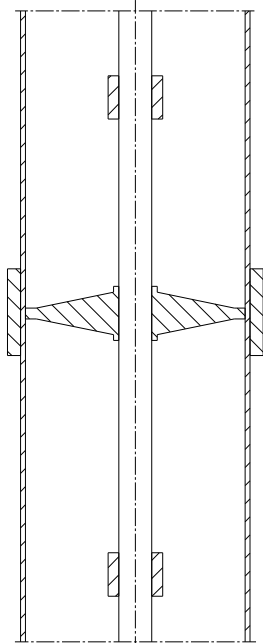

TM051476

Fig. 13 Column cross-section showing placement of bearing retainer

5.5.6 Installing the discharge head

With the pump and all the standard-length column and shaft sections installed in the well or sump, the next step is to prepare the discharge head and top column section for installation.



Warning
Exceeding the load limitations of the hoist may result in failure of the discharge head, serious damage to other parts of the pump and grave injury to nearby personnel. See the construction drawing for weights of pump components.

The size designation of the discharge head is given in raised numbers cast on the side or top of the mounting plate for cast heads. Fabricated heads may have it stamped on the base.

The discharge head will be shipped from the factory without the driver assembled to it.

1. Place the discharge head on a clean work surface near the sump.
2. If the discharge head has become soiled in shipping and handling, clean it thoroughly, inside and outside.
3. If a sole plate is to be used, check the mounting surface at the top of the sole plate for possible damage or debris. Remove any burrs and clean the surface thoroughly.
4. If the sole plate has been painted, remove the paint from the machined side.
5. Ensure that the stuffing box register and top column register are free of debris and coating.
6. When the discharge outlet of the pump is a plain pipe (no threads or flange) and a flexible discharge coupling is to be used, the parts of the coupling must be installed on the pump outlet and/or discharge piping before locating the discharge head in its final position.
7. Install the top shaft (head shaft) and the top column section in the same manner as for the standard sections.

Note Do not lower the top column section into the sump at this time.

Caution When lowering the top column section over the top shaft (or head shaft), take care not to bump or scrape the shaft. This could bend the shaft and/or damage the shaft threads.

8. Attach the sling to the eyebolts and hoist the discharge head over the pump (the lifting ears are not used to lift the discharge head when not attached to the pump because the discharge head is heavier on the discharge side and would tip). Very large discharge heads that are too heavy to lift by the driver mounting holes may be lifted via slings through the hand holes or by passing a bar through the hand holes. See fig. 14.

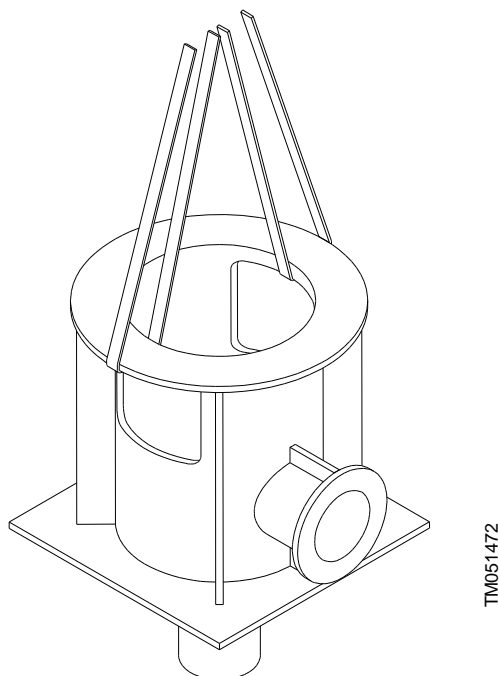

Fig. 14 Lifting large discharge heads using slings

10. Place gaskets or O-ring on the upper flange of the top column section.
11. Remove the stuffing box from the head, if installed.
12. Lower the discharge head slowly, centering the shaft in the discharge head so that there will no bumping or scraping as the shaft enters and passes through the hole.
13. Continue to lower the discharge head until the studs enter the holes in the flange of the top column section and the discharge head is correctly seated in place.
14. Fit the nuts on the studs, tightening them gradually and uniformly.
15. Raise the entire unit a few inches and remove the box clamp.
16. After the discharge head is installed on the pump column, always use the lifting ears on the discharge head for hoisting the pump.



Warning
Never attempt to lift the pump by means of eyebolts screwed into the driver mounting holes because the bolts are not strong enough to carry the weight of the entire pump.

17. Install stuffing box assembly.

Solesolesole

5.7 Piping and connections

5.7.1 Pipe supports, anchors or joints

Suction and discharge piping should be anchored, supported and restrained near the pump to avoid application of forces and moments to the pump. Pipe strain is not acceptable and could affect, and or shorten, the lifespan of the pump or cause unacceptable vibration.

In order to achieve optimum operation and minimum noise and vibration, consider vibration dampening of the pump.

5.7.3 Suction piping

A vertical pump in a suction barrel performs properly only if it is supplied with a steady flow of liquid with a uniform velocity profile and with sufficient pressure to provide adequate NPSH to the pump.

Failure of the suction piping to deliver the liquid to the pump in this condition can lead to noisy operation, swirling of liquid around the suspended pump assembly, premature bearing failure and cavitation damage to the impeller and inlet portions of the casing.

Contact Peerless Pump for further information.

5.7.5 Discharge valves

A non-return valve and an isolation valve should be installed in the discharge pipe. The non-return valve serves to protect the pump from backflow and excessive backpressure. The isolation valve is used when starting and stopping the pump. Except on axial-flow and mixed-flow pumps, we recommend to close the discharge valve before stopping or starting the pump.

Continued operation at shutoff may cause a dangerous increase in pressure or power. If increasers are used on the discharge side of the pump to increase the size of piping, they should be placed between the non-return valve and the pump.

If expansion joints are used, they should be placed between the pipe anchor and the non-return valve.

Non-return valves may be installed in the discharge pipe to prevent backflow. In some applications, non-return valves may be provided with dashpots to mitigate the slamming effect of the valve during closing.

Pump backspin and hydraulic shock can cause severe damage to pump and motor. Install at least one non-return valve in the discharge pipe, not more than 25 feet (7.5 m) after the discharge flange to help prevent this.

5.7.6 Air and vacuum release valves for wet pit and well pumps

Vertical wet pit pumps discharging into a pressurized system, an automatic air and vacuum release valve is recommended. The valve should be located on the pump discharge nozzle or between the pump discharge nozzle and the discharge valve or non-return valve, whichever is closest, or on the discharge head.

The release valve prevents a large volume of air from being compressed and then setting up a severe shock wave when suddenly released, with potential for serious equipment damage.

It also prevents air from entering the pressurized system.

The valve also relieves the vacuum that might otherwise be generated in the discharge during shutdown when the liquid recedes in the column pipe to the sump or well standing level. Vacuum release valves may be critically important to prevent equipment damage.

5.7.7 Siphons

When a siphon is used in the pump discharge line, for the purpose of reducing the head requirement for applications



such as pumping over a levee, additional equipment requirements are imposed for the system to function satisfactorily.

To clear the siphon of air and make it operational, either a vacuum pump or an air ejector should be provided, or the pump and driver should be suitable for handling the higher head with adequate flow until the siphon is cleared. For high-specific-speed pumps, this may result in a significant increase in required brake horsepower. Additionally, if the height of the siphon above the discharge water level is substantial, then the flow from the pump at the increased head requirement may not be sufficient to clear the siphon, and a vacuum pump assist is required.

A siphon breaker should be mounted at the high point of the siphon to prevent backflow when the pump is stopped.

5.7.8 Nozzle loads

The piping should be aligned with the pump nozzles to minimize pump nozzle loads. Contact Peerless Pump for allowable nozzle loading for your given design.

5.7.10 Strainer

To keep unwanted solids out of the pump, a strainer may be installed at the suction bell or case. Accumulation of debris can induce a moderate pressure drop. The strainer typically clears itself by backflow in the pump column when the unit is stopped.

If a pressure drop occurs, check the strainer for debris buildup.





5.8 Setting the impeller clearance HIGHLIGHT AS A COMMENT, NOTE, OR SOMETHING

The rotating element (shaft and impeller) should be raised axially before startup. An adjusting nut or pump-to-driver shaft coupling is provided for this purpose, and the pump shaft should be raised according to the table below (column "Best lateral").

For deep-set well pumps or high thrust load pumps, where shaft elongation and accumulation of column shaft joint tolerances could affect the clearance between the impeller and the bowl, it is important that an accurate determination of shaft stretch be determined which needs to be added to the best lateral setting in the table below in order to prevent interference during pump operation. Failure to account for this may result in catastrophic failure.

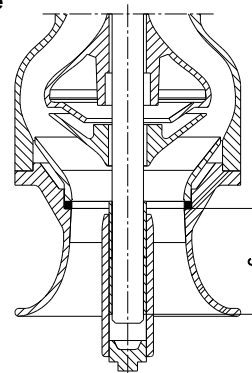

TM051478

The table also shows the most efficient bearing and impeller clearances.

- B Distance from bottom of impeller to end of shaft (suction case)
- C Distance from bottom of impeller to end of shaft (suction bell)
- D Nominal diametrical clearance between shaft and bearings
- E Nominal diametrical clearance between impeller skirt and bowl side seal

The values are dimensional references only. No guarantees implied. Information subject to change without notice. All dimensions are inches (mm).

Size	Model	Shaft Diameter	B	C	D (max.)	E (min)	E (max)	Best Lateral
4	LE	0.75 (19.05)	5.19 (131.83)		0.004 (0.1)	0.006 (0.15)	0.01 (0.25)	0.125 (3.18)
6	HXB	0.88 (22.35)	4.56 (115.82)		0.005 (0.13)	0.008 (0.2)	0.012 (0.3)	0.125 (3.18)
6	LB	0.88 (22.35)	3.38 (85.85)	3.38 (85.85)	0.005 (0.13)	0.007 (0.18)	0.011 (0.28)	0.125 (3.18)
6	MA	0.88 (22.35)	6.56 (166.62)	3.69 (93.73)	0.005 (0.13)	0.01 (0.25)	0.015 (0.38)	0.063 (1.6)
7	HXB	1 (25.4)	5.63 (143)		0.005 (0.13)	0.008 (0.2)	0.012 (0.3)	0.125 (3.18)
7	LA	1 (25.4)	6.5 (165.1)	4.06 (103.12)	0.005 (0.13)	0.008 (0.2)	0.012 (0.3)	0.125 (3.18)
7	LB	1 (25.4)	7 (177.8)	7 (177.8)	0.005 (0.13)	0.012 (0.3)	0.018 (0.46)	0.125 (3.18)
8	HDX HDX (w/o ring)	1.19 (30.23)	6.38 (162.05)		0.006 (0.15)	0.012 (0.3)	0.018 (0.46)	0.063 (1.6)
8	HXB	1.19 (30.23)	5.44 (138.18)		0.006 (0.15)	0.008 (0.2)	0.012 (0.3)	0.063 (1.6)
8	LB	1.19 (30.23)	4.38 (111.25)	4.38 (111.25)	0.006 (0.15)	0.008 (0.2)	0.012 (0.3)	0.125 (3.18)
8	MA	1.19 (30.23)	7.63 (193.8)	3.94 (100.08)	0.006 (0.15)	0.008 (0.2)	0.012 (0.3)	0.125 (3.18)
8	MFH	1.19 (30.23)	0.006 (0.15)		0.006 (0.15)			0.012 (0.3)
8	M8LB	1.19 (30.23)	4.5 (114.3)	4.5 (114.3)	0.006 (0.15)	0.008 (0.2)	0.012 (0.3)	0.125 (3.18)
8	M8MA	1.19 (30.23)	4.5 (114.3)	4.5 (114.3)	0.006 (0.15)	0.008 (0.2)	0.012 (0.3)	0.125 (3.18)
9	LA	1.19 (30.23)	8 (203.2)	4.75 (120.65)	0.006 (0.15)	0.008 (0.2)	0.012 (0.3)	0.125 (3.18)
10	HH	1.5 (38.1)	8.88 (225.55)	8.88 (225.55)	0.006 (0.15)	0.008 (0.2)	0.012 (0.3)	0.063 (1.6)
10	HXB	1.5 (38.1)	8.25 (209.55)	4.81 (122.17)	0.006 (0.15)	0.008 (0.2)	0.012 (0.3)	0.188 (4.78)
10	LB	1.19 (30.23)	8.19 (208.03)	8.19 (208.03)	0.006 (0.15)	0.008 (0.2)	0.012 (0.3)	0.125 (3.18)
10	MA	1.19 (30.23)	8 (203.2)	4.31 (109.47)	0.006 (0.15)	0.008 (0.2)	0.012 (0.3)	0.125 (3.18)
10	MF	1 (25.4)	Keyed	Keyed	0.006 (0.15)			0.012 (0.3)
10	MFH	1.5 (38.1)	Keyed	Keyed	0.006 (0.15)			0.012 (0.3)
10	PL	1.19 (30.23)	Keyed	Keyed	0.006 (0.15)			Middle(*)
10	M10LA	1.19 (30.23)	5.75 (146.05)	5.75 (146.05)	0.006 (0.15)	0.008 (0.2)	0.012 (0.3)	0.125 (3.18)
10	M10LB	1.19 (30.23)	5.75 (146.05)	5.75 (146.05)	0.006 (0.15)	0.008 (0.2)	0.012 (0.3)	0.125 (3.18)
10	M10MA	1.19 (30.23)	5.81 (147.57)	5.81 (147.57)	0.006 (0.15)	0.008 (0.2)	0.012 (0.3)	0.125 (3.18)
11	MB	1.94 (49.28)	9.25 (234.95)		0.007 (0.18)	0.011 (0.28)	0.015 (0.38)	0.125 (3.18)
12	HD	1.94 (49.28)	8.88 (225.55)		0.007 (0.18)	0.008 (0.2)	0.012 (0.3)	0.125 (3.18)





OLS Vertical Turbine Installation, Operation
and Maintenance Manual

Size	Model	Shaft Diameter	B	C	D (max.)	E (min)	E (max)	Best Lateral
12	HD (w/o ring)	1.94 (49.28)	8.63 (219.2)		0.007 (0.18)	0.008 (0.2)	0.012 (0.3)	0.125 (3.18)
12	HXB	1.5 (38.1)	9.75 (247.65)	2.25 (57.15)	0.006 (0.15)	0.008 (0.2)	0.012 (0.3)	0.125 (3.18)
12	HXH	1.94 (49.28)	8.44 (214.38)	8.44 (214.38)	0.007 (0.18)	0.008 (0.2)	0.012 (0.3)	0.063 (1.6)
12	LB	1.5 (38.1)	7.81 (198.37)	7.81 (198.37)	0.006 (0.15)	0.008 (0.2)	0.013 (0.33)	0.125 (3.18)
12	LD	1.5 (38.1)	7.06 (179.32)	7.06 (179.32)	0.006 (0.15)	0.01 (0.25)	0.015 (0.38)	0.063 (1.6)
12	LD (w/op ring)	1.5 (38.1)	6.75 (171.45)	6.75 (171.45)	0.006 (0.15)	0.01 (0.25)	0.015 (0.38)	0.063 (1.6)
12	LDT	1.5 (38.1)	7.13 (181.1)	7.13 (181.1)	0.006 (0.15)	0.01 (0.25)	0.015 (0.38)	0.125 (3.18)
12	LDT (w/o ring)	1.5 (38.1)	6.88 (174.75)	6.88 (174.75)	0.006 (0.15)	0.01 (0.25)	0.015 (0.38)	0.125 (3.18)
12	MB	1.5 (38.1)	9.38 (238.25)	3.13 (79.5)	0.006 (0.15)	0.011 (0.28)	0.015 (0.38)	0.188 (4.78)
12	MF	1.19 (30.23)	Keyed	Keyed	0.006 (0.15)			0.012 (0.3)
12	PL	1.19 (30.23)	Keyed	Keyed	0.006 (0.15)			Middle(*)
12	M12HXB	1.5 (38.1)	7.56 (192.02)	7.56 (192.02)	0.006 (0.15)	0.01 (0.25)	0.015 (0.38)	0.063 (1.6)
12	M12LD	1.5 (38.1)	7.06 (179.32)	7.06 (179.32)	0.006 (0.15)	0.01 (0.25)	0.015 (0.38)	0.063 (1.6)
12	M12LDT	1.5 (38.1)	7.06 (179.32)	7.06 (179.32)	0.006 (0.15)	0.01 (0.25)	0.015 (0.38)	0.125 (3.18)
12	M12MB	1.5 (38.1)	7.5 (190.5)	7.5 (190.5)	0.006 (0.15)	0.01 (0.25)	0.015 (0.38)	0.188 (4.78)
14	HH	1.69 (42.93)	9 (228.6)	9 (228.6)	0.007 (0.18)	0.011 (0.28)	0.015 (0.38)	0.063 (1.6)
14	HXB	1.94 (49.28)	9.72 (246.89)	3.44 (87.38)	0.007 (0.18)	0.01 (0.25)	0.016 (0.41)	0.125 (3.18)
14	LA	1.94 (49.28)	10.38 (263.65)	7.06 (179.32)	0.007 (0.18)	0.008 (0.2)	0.012 (0.3)	0.125 (3.18)
14	LC	1.94 (49.28)	9.56 (242.82)	9.56 (242.82)	0.007 (0.18)	0.008 (0.2)	0.012 (0.3)	0.125 (3.18)
14	LD	1.94 (49.28)	8.38 (212.85)	8.38 (212.85)	0.007 (0.18)	0.013 (0.33)	0.017 (0.43)	0.063 (1.6)
14	LD (w/op ring)	1.94 (49.28)	8.06 (204.72)	8.06 (204.72)	0.007 (0.18)	0.013 (0.33)	0.017 (0.43)	0.063 (1.6)
14	MC	1.94 (49.28)	9.75 (247.65)	9.75 (247.65)	0.007 (0.18)	0.012 (0.3)	0.018 (0.46)	0.125 (3.18)
14	MD	1.94 (49.28)	9.88 (250.95)	9.88 (250.95)	0.007 (0.18)	0.012 (0.3)	0.018 (0.46)	0.125 (3.18)
14	MF	1.5 (38.1)	Keyed	Keyed	0.006 (0.15)			0.015 (0.38)
14	MFAH	1.5 (38.1)	Keyed	Keyed	0.006 (0.15)			0.015 (0.38)
14	PL	1.5 (38.1)	Keyed	Keyed	0.006 (0.15)			Middle(*)
14	M14HXB	1.94 (49.28)	7.5 (190.5)	7.5 (190.5)	0.007 (0.18)	0.012 (0.3)	0.018 (0.46)	0.125 (3.18)
14	M14LD	1.94 (49.28)	6.19 (157.23)	6.19 (157.23)	0.007 (0.18)	0.012 (0.3)	0.018 (0.46)	0.063 (1.6)
14	M14MC	1.94 (49.28)	7.38 (187.45)	7.38 (187.45)	0.007 (0.18)	0.012 (0.3)	0.018 (0.46)	0.063 (1.6)
15	LC	2.19 (55.63)	9.25 (234.95)	9.81 (249.17)	0.007 (0.18)	0.008 (0.2)	0.012 (0.3)	0.125 (3.18)
15	MA	2.19 (55.63)	9.81 (249.17)		0.007 (0.18)	0.011 (0.28)	0.015 (0.38)	0.125 (3.18)
16	HH	1.94 (49.28)	9.75 (247.65)	9.75 (247.65)	0.007 (0.18)	0.011 (0.28)	0.015 (0.38)	0.063 (1.6)
16	HXB	1.94 (49.28)	9.5 (241.3)	9.5 (241.3)	0.007 (0.18)	0.011 (0.28)	0.015 (0.38)	0.125 (3.18)
16	MC	1.94 (49.28)	9.75 (247.65)	9.75 (247.65)	0.007 (0.18)	0.012 (0.3)	0.018 (0.46)	0.063 (1.6)
16	MF	1.69 (42.93)	Keyed	Keyed	0.007 (0.18)			0.018 (0.46)
16	PL	1.5 (38.1)	Keyed	Keyed	0.007 (0.18)			Middle(*)
18	HXB	1.94 (49.28)	8.38 (212.85)	8.38 (212.85)	0.007 (0.18)	0.011 (0.28)	0.015 (0.38)	0.063 (1.6)
18	MA	1.94 (49.28)	11.13 (282.7)	6.31 (160.27)	0.007 (0.18)	0.015 (0.38)	0.021 (0.53)	0.063 (1.6)
18	HH	2.19 (55.63)	Keyed	Keyed	0.007 (0.18)	0.012 (0.3)	0.019 (0.48)	0.063 (1.6)
18	MF	1.94 (49.28)	Keyed	Keyed	0.007 (0.18)			0.018 (0.46)
18	MFAL	1.94 (49.28)	Keyed	Keyed	0.007 (0.18)			0.018 (0.46)
18	PL	1.5 (38.1)	Keyed	Keyed	0.007 (0.18)			Middle(*)
20	HH	2.19 (55.63)	Keyed	Keyed	0.007 (0.18)	0.015 (0.38)	0.019 (0.48)	0.063 (1.6)
20	HXB	2.19 (55.63)	10.56 (268.22)	10.56 (268.22)	0.007 (0.18)	0.014 (0.36)	0.018 (0.46)	0.063 (1.6)
20	MA	2.19 (55.63)	11.75 (298.45)	11.75 (298.45)	0.007 (0.18)	0.01 (0.25)	0.015 (0.38)	0.063 (1.6)
20	MF	1.69 (42.93)	Keyed	Keyed	0.007 (0.18)			0.02 (0.51)
20	MFAL	2.19 (55.63)	Keyed	Keyed	0.007 (0.18)			0.02 (0.51)



OLS Vertical Turbine Installation, Operation and
Maintenance Manual



Size	Model	Shaft Diameter	B	C	D (max.)	E (min)	E (max)	Best Lateral
20	PL	1.5 (38.1)	Keyed	Keyed	0.007 (0.18)			Middle(*)
24	HH	2.44 (61.98)	Keyed	Keyed	0.011 (0.28)	0.015 (0.38)	0.019 (0.48)	0.125 (3.18)
24	H HOH	2.44 (61.98)	Keyed	Keyed	0.011 (0.28)			0.031 (0.79)
24	HXB	2.19 (55.63)	Keyed	Keyed	0.007 (0.18)	0.015 (0.38)	0.019 (0.48)	0.125 (3.18)
24	HXC	2.19 (55.63)	Keyed	Keyed	0.007 (0.18)	0.015 (0.38)	0.019 (0.48)	0.125 (3.18)
24	MA	2.44 (61.98)	Keyed	Keyed	0.011 (0.28)	0.014 (0.36)	0.018 (0.46)	0.063 (1.6)
24	MF	2.44 (61.98)	Keyed	Keyed	0.011 (0.28)			0.02 (0.51)
24	MFH	2.44 (61.98)	Keyed	Keyed	0.011 (0.28)			0.02 (0.51)
24	PL	1.69 (42.93)	Keyed	Keyed	0.007 (0.18)			Middle(*)
26	HH	2.94 (74.68)	Keyed	Keyed	0.01 (0.25)	0.015 (0.38)	0.019 (0.48)	0.125 (3.18)
26	H HOH	2.94 (74.68)	Keyed	Keyed	0.01 (0.25)			0.031 (0.79)
26	HXB	2.94 (74.68)	Keyed	Keyed	0.01 (0.25)	0.015 (0.38)	0.019 (0.48)	0.063 (1.6)
27	MA	2.94 (74.68)	Keyed	Keyed	0.01 (0.25)	0.016 (0.41)	0.02 (0.51)	0.063 (1.6)
28	HXB	2.94 (74.68)	Keyed	Keyed	0.01 (0.25)	0.017 (0.43)	0.021 (0.53)	0.031 (0.79)
30	HH	2.94 (74.68)	Keyed	Keyed	0.01 (0.25)	0.018 (0.46)	0.022 (0.56)	0.125 (3.18)
30	H HOH	2.94 (74.68)	Keyed	Keyed	0.01 (0.25)			0.031 (0.79)
30	LA	2.69 (68.33)	Keyed	Keyed	0.009 (0.23)	0.015 (0.38)	0.021 (0.53)	0.063 (1.6)
30	MF	1.69 (42.93)	Keyed	Keyed	0.007 (0.18)			0.026 (0.66)
30	MFAH	2.44 (61.98)	Keyed	Keyed	0.011 (0.28)			0.026 (0.66)
30	MFAL	2.44 (61.98)	Keyed	Keyed	0.011 (0.28)			0.026 (0.66)
30	MFH	2.44 (61.98)	Keyed	Keyed	0.011 (0.28)			0.026 (0.66)
30	PL	2.19 (55.63)	Keyed	Keyed	0.007 (0.18)			Middle(*)
32	HXB	3.69 (93.73)	Keyed	Keyed	0.012 (0.3)	0.017 (0.43)	0.021 (0.53)	0.031 (0.79)
36	HH	3.69 (93.73)	Keyed	Keyed	0.012 (0.3)	0.015 (0.38)	0.025 (0.64)	0.125 (3.18)
36	H HOH	3.69 (93.73)	Keyed	Keyed	0.012 (0.3)			0.031 (0.79)
36	HXB	3.94 (100.08)	Keyed	Keyed	0.012 (0.3)	0.018 (0.46)	0.022 (0.56)	0.125 (3.18)
36	MA	3.69 (93.73)	Keyed	Keyed	0.012 (0.3)	0.014 (0.36)	0.018 (0.46)	0.125 (3.18)
36	MF	3.44 (87.38)	Keyed	Keyed	0.01 (0.25)			0.029 (0.74)
36	MFH	3.44 (87.38)	Keyed	Keyed	0.01 (0.25)			0.029 (0.74)
36	PL	2.44 (61.98)	Keyed	Keyed	0.011 (0.28)			Middle(*)
42	HH	3.94 (100.08)	Keyed	Keyed	0.012 (0.3)	0.015 (0.38)	0.025 (0.64)	0.125 (3.18)
42	HXB	3.94 (100.08)	Keyed	Keyed	0.012 (0.3)	0.018 (0.46)	0.022 (0.56)	0.125 (3.18)
42	MF	3.44 (87.38)	Keyed	Keyed	0.01 (0.25)			0.036 (0.91)
42	MFH	3.44 (87.38)	Keyed	Keyed	0.01 (0.25)			0.036 (0.91)
42	PL	2.44 (61.98)	Keyed	Keyed	0.011 (0.28)			Middle(*)
48	HH	3.94 (100.08)	Keyed	Keyed	0.012 (0.3)	0.019 (0.48)	0.028 (0.71)	0.125 (3.18)
48	H HOH	3.94 (100.08)	Keyed	Keyed	0.012 (0.3)			0.047 (1.19)
48	HXB	3.94 (100.08)	Keyed	Keyed	0.012 (0.3)	0.019 (0.48)	0.025 (0.64)	0.125 (3.18)
48	MF	3.44 (87.38)	Keyed	Keyed	0.01 (0.25)			0.042 (1.07)
48	PL	2.69 (68.33)	Keyed	Keyed	0.009 (0.23)			Middle(*)
54	MF	3.94 (100.08)	Keyed	Keyed	0.012 (0.3)			0.048 (1.22)
54	PL	3.19 (81.03)	Keyed	Keyed	0.01 (0.25)			Middle(*)
56	HH	4.25 (107.95)	Keyed	Keyed	0.012 (0.3)			0.125 (3.18)
56	H HOH	4.25 (107.95)	Keyed	Keyed	0.012 (0.3)			0.047 (1.19)
60	PL	3.94 (100.08)	Keyed	Keyed	0.012 (0.3)			Middle(*)
66	HH		Keyed	Keyed	0.012 (0.3)			0.125 (3.18)
66	MF	4.94 (125.48)	Keyed	Keyed	0.012 (0.3)			0.054 (1.37)

* Measure the lateral movement of the impeller and set the impeller at half of that distance.





OLS Vertical Turbine Installation, Operation
and Maintenance Manual



5.9 Alignment

For VHS drivers, check rotation of motor before installing motor shaft.

Caution

For VSS drivers, check rotation before coupling the motor to the pump. The lower coupling half and adjusting nut should be positioned below the top end of the pump shaft and securely restrained to prevent accidental contact with the rotating motor shaft and coupling when verifying motor rotation.

Proper rotation is counterclockwise when viewed from above.

Caution

Check impeller lateral adjustment prior to starting the coupled pump. Improperly set lateral could result in damage to the pump.

Vertical line-shaft pumps are automatically aligned through registered fits between mating parts. However, we recommend to check the alignment of the head shaft to the driver at the time of final installation.

After the grout has set and the foundation bolts have been properly tightened, the unit alignment should be checked. After the discharge piping of the unit has been connected, the alignment should be checked again. Alignment may be checked by mounting a dial indicator to measure shaft movement before and after tightening flange bolts. If the unit does not stay in alignment after being properly installed, the following are possible causes:

- setting, seasoning or springing of the foundation
- excessive pipe strain distorting or shifting the machine.

5.9.1 Auxiliary (driver, coupling, etc)

Vertical solid-shaft (VSS) drivers

1. If an existing motor is to be utilized, before mounting the driver on the discharge head/driver stand, check the register fit, if furnished, and the mounting face on the driver for acceptable tolerance on run out and perpendicularity, respectively, using a dial indicator mounted on the driver shaft.
2. Before mounting the motor on the discharge head, install the key in the motor shaft.
3. Mount the motor coupling half on the motor shaft and freely slide it up over the key until there is access to the motor shaft groove. Install the split rings in the groove and slide the motor coupling half back down until it contacts and traps the split ring halves. Lightly tap the coupling half down to be sure it is fully seated against the split rings.
4. Mount the pump key, pump half coupling, shaft adjusting nut, and coupling spacer, if applicable, on line shaft. Locate below the top of the shaft before setting the motor.
5. Mount the driver on the discharge head using proper lifting equipment.
6. Before connecting any coupling parts, check the driver for correct rotation (counter-clockwise when viewed from above). Tie the adjusting nut down to be sure it can not climb up the shaft while bumping the motor.
7. Rotate the adjusting nut as necessary to obtain a gap of 0.0625 inch (1.6 mm) between the lower face of the driver half coupling, or spacer if applicable, and the upper surface of the adjusting nut as shown in fig. 15. Rotate the adjusting nut to align bolt holes
8. Insert two bolts on opposite sides of the coupling assembly and hand tighten nuts onto bolts.

9. Gradually and uniformly tighten bolts in alternating cross pattern until the coupling is tight.

10. Manually rotate the shaft to ensure free rotation. If any resistance is felt, remove bolts and turn adjusting nut downward in 0.03 inch (0.76mm) increments and repeat above steps until free rotation is achieved.

11. Loosen the bolts and lower the adjusting nut by the lateral setting determined using section 5.8 (lateral from the chart plus possible adjustment for shaft stretch). It may be helpful to measure the gap after loosening the bolts or mark the shaft below the nut by the lateral amount before lowering the nut to the final position.

12. Secure all coupling bolts, locking washers, and nuts so the adjusting nut is fully seated against the motor coupling or spacer.

13. Verify again that the shaft rotates freely.

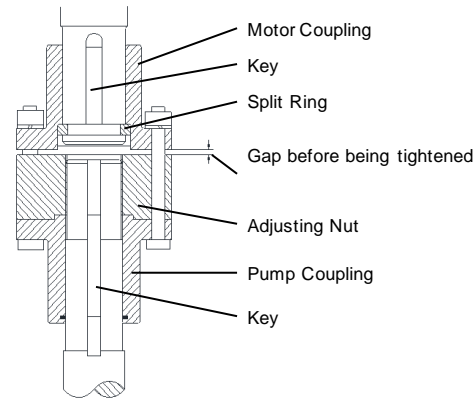

Fig. 15 Motor Coupling

Vertical hollow-shaft (VHS) drivers

1. Check the driver for correct rotation (counter-clockwise when viewed from above) before installing the shaft.
2. For pump designs with line shaft coupled above the packing container, mount the driver on top of the discharge head/driver stand. Install the steady bushing, if provided, over the head shaft while lowering the head shaft through the hollow shaft driver. Connect the head shaft at the line shaft coupling.
4. Install the coupling gib key and the adjusting nut.
5. Turn the adjusting nut until the shaft lifts sufficiently to allow the shaft to turn freely by hand..
6. Turn the adjusting nut to achieve the best lateral setting in accordance with section 5.8. If the maximum expected shaft elongation at any point on the performance curve is bigger than 1/2 of the suggested lateral setting from the bowl table, increase the setting by the amount of maximum elongation.
7. Secure the adjusting nut to the drive coupling or clutch and double-check the driver hold-down bolts for tightness.
8. Ensure pump turns freely.

5.10 Lubrication, priming and cooling systems

If supplied, please see additional documents attached to the pump or contact Peerless Pump.



OLS Vertical Turbine Installation, Operation and Maintenance Manual

5.12 Control, monitoring and alarm equipment

All control and alarm systems should be checked for correct installation and functioning in accordance with the manufacturer's instructions. All alarm point settings should be checked.

Once pumping starts, the water level in the well will draw down.

However, excessive drawdown may cause the pump to break suction, with resulting potential pump damage. Installation of undercurrent relays in the power supply lines will normally provide protection against this occurrence.

5.12.1 Stopping the unit/reverse runaway speed

A sudden power and/or discharge valve failure during pump operation against a static head will result in a flow reversal, and the pump will operate as a hydraulic turbine in a direction opposite to that of normal pump operation. Vertical pump drivers can be equipped with non-reverse ratchets to prevent reverse rotation. However, their application is not always desirable and a review should always be made with Peerless Pump prior to installing.

6. Startup, operation and shutdown



Warning

The pump must not be operated beyond the parameters specified for the application. If there is any doubt as to the suitability of the product for the application intended, have the serial number ready and contact Peerless Pump for advice.

If the conditions of service on your purchase order are going to be changed, (for example liquid pumped, temperature or duty), seek written agreement from Peerless Pump.

6.1 Frost protection

If the pump is to be used in area where there is a potential of freezing or frost, necessary steps should be taken to protect pump and cooling systems from freezing and bursting.

6.2 Lubrication

Before attempting to start the pump, check the following items:

- lubrication fitting at packing (if applicable)
- settings with water level 50 ft below the discharge may require prelubrication of the line shaft bearings (see section 6.6.4 Lubrication system)
- lubrication of the driver
- oil-cooling connections for the driver (if applicable).

6.2.1 Recommended products

The products listed in the following tables are recommended for the applications mentioned. Other lubricants of equal quality may also be used.

Greases for line shaft bearings, suction manifold bearings and shaft packings

Maximum 3600 rpm. -20° to +120 °F (-29° to 50 °C).

Manufacturer	Product
American Oil Co.	AMOCO Lithium Grease All-Weather
Atlantic Richfield Co.	ARCO Multipurpose Grease
Cato Oil & Grease Co	Mystik JT-6
Cities Service Oil Co.	Citgo H-2

Continental Oil Co.	EP Conolith No. 1 -20° to +40 °F (-28° to +4 °C)
Continental Oil Co.	EP Conolith No. 2 +40° to +120 °F (+4° to +50 °C)
Gulf Oil Co	Gulf Crown No. 2 or Ep 2
E.F. Houghton & Co.	Cosmolube No. 2
Exxon	Lidok Ep 2
Hydrotex	Deluxe No. M-33 Super Shield
Imperial Oil & Grease Co.	Molub-Alloy No. 1
Keystone Div., Pennwalt Corp.	80 X LT
Mobil Oil Corp	Mobilux Ep No. 2
The Pennzoil Co.	Pennzoil 705 HDW
Phillips Petroleum Co.	Philube IB & RB
Shell Oil Co.	Alvania EP Grease Alvania EP Grease 1 (for prolonged ambient temperature below 0 °F (-18 °C))
Sun Oil Co.	Sunaplex No. 2 EP Prestige 42
Texaco, Inc.	Novatex Grease No. 2
Union Oil Co	Unoba Ep-2

Food grade (H-1 rated) greases for line shaft bearings, suction manifold bearings and similar applications

Maximum 3600 rpm.

Manufacturer	Product
Husk-ltt	Huskey Lube "0" Seal
Texaco	Cygnus
Royal	FG 32

Sealants for use on low-pressure flanged joints and similar applications

Manufacturer	Product
Loctite Corporation	Loctite #515

6.3 Rotation

Non-reverse ratchets are typically furnished as an integral part of the motor or right-angle gear when reverse rotation from backflow in the pump may cause damage.

1. While the motor or gear is disconnected from the pump, rotate the motor or gear by hand in both directions to check proper functioning of the ratchet. The rotation of the complete drive train should also be checked at this time.
2. Before starting the pump, check the direction of rotation. The correct direction of rotation is counter-clockwise when viewed from the top and is usually indicated by a direction arrow on the discharge head or on the driver stand when the discharge is located below the mounting level.

6.4 Guards

Warning

All guards must be in place on the pump discharge head prior to startup. Read and follow all recommended guarding and safety instructions for accessories, if any.



Guards must not be removed while the pump is operational



6.5 Check list

6.5.1 System flushing

Before pump is put into operation, the system piping and sump should be clean of all debris such as stubs of welding rod, welding slag and loose scale.

6.5.3 Priming

The pump should not be run unless it is submerged to the minimum required depth, as there is danger of damaging some of the pump components.

6.5.4 Shaft sealing

Stuffing box

If the stuffing box is not packed from factory, the following may be used as a guide.

1. Clean the stuffing box.
2. Check that the packing rings are of proper cross-section and length.
3. Stagger the joints 180° apart.
4. The rings should butt tightly but not overlap at the joints.
5. Seat the individual packing rings, but not too tightly, as this may result in burning the packing and scoring the shaft or shaft sleeve.
6. Where compatible, lightly lubricate the inner packing diameter with a suitable lubricant. When a lantern ring is required, make sure that sufficient packing is placed in below the lantern ring so that the bypass line hole intersects the packing container bore in line with the lantern ring and is not blocked by the packing.
7. The pipe supplying sealing liquid should be fitted tightly so that no air enters. See fig. 16. If the liquid to be pumped is dirty or gritty, clean sealing liquid should be piped to the stuffing box in order to prevent damage to the packing and shaft sleeves.

Clear sealing liquid is also required if the stuffing box materials are not completely compatible with the pump liquid. The sealing liquid should be at a pressure sufficient to ensure a flow of clean liquid into the pump but not so high as to require excessive tightening of the packing.

Caution The stuffing box gland must not be too tight during startup in order to let sufficient liquid lubricate the shaft and the packing.

8. Once the stuffing box housing and stuffing box gland have reached approximately the same temperature as that of the pump parts, the running-in of the stuffing box gland has been completed. If the stuffing box leaks too much, retighten slightly and evenly while the pump is running. To ensure continuous lubrication, a few drops should always drop from the stuffing box to protect the packing or shaft sleeve against damage. 20 to 40 drops/minute as a minimum are recommended. Packing must be adjusted under actual running conditions and speeds.

When the leakage can no longer be controlled by adjusting the gland, all rings of packing should be replaced. The addition of a single ring to restore gland adjustment is not recommended.

If the pump is to be left idle for a long period of time, we recommend to replace the packing prior to restarting the pump.

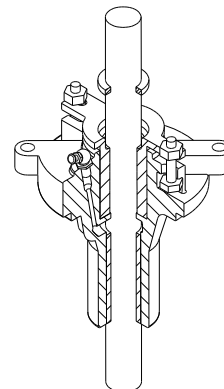

TM051621

Fig. 16 Stuffing box

Mechanical seal

Prior to installing and setting mechanical seal, it is important to establish the lateral setting of the pump. Lateral movement after seal installation could damage seal by reducing seal gap or opening which will increase leakage.

Mechanical seals normally require no adjustment during operation. Except for possible slight initial leakage, the seal should operate with negligible leakage.

Caution Mechanical shaft seals should not run dry.

Shaft seals may require a continuous supply of flush and/or cooling liquid. Where seal damage due to system uncleanliness is expected, it may be advisable to operate the pump with packing or temporary seals and sleeves until the system is clean.

6.6 Startup, operation and shutdown

Caution Start the pump with outlet valve partly opened unless otherwise instructed by Peerless Pump.

Inlet valves must be fully open when pump is running.

Caution Running the pump at zero flow or below the recommended minimum flow rate continuously will cause damage to the seal, bearings, rotating element and other equipment.

Operating the pump outside its allowable operating range as indicated on performance curves will reduce the overall pump life.

Caution Operating at a flow rate higher than normal and/or at a flow rate with no backpressure on the pump may overload the motor and cause cavitation.

Low flow rates may cause a reduction in pump/bearing life, overheating of the pump, instability and cavitation/vibration.

Caution Check impeller lateral adjustment prior to starting the pump. Improperly set lateral could result in damage to the pump.

6.6.1 Air in system



OLS Vertical Turbine Installation, Operation and Maintenance Manual

Entrained air reduces pump total head and flow rate. To avoid air in the system, take these precautions:

- Avoid cascading water.
- For well pumps, locate the perforated casing below the pump suction.
- Return lines into sumps or tanks should terminate a minimum of two pipe diameters below the low liquid level.
- Install strainers and trash racks of sufficient size.
- Make adequate provisions for cleaning rotating screen and trash racks.

6.6.2 Minimum continuous flow

See Peerless Pump performance curves.

6.6.3 Minimum thermal flow

See Peerless Pump performance curves.

6.6.4 Lubrication system

Before running the drivers, either separately or connected to the pump, check lubrication requirements in the instructions of the driver. Check that the following points have been fulfilled:

- Grease-lubricated bearings have been properly greased with the driver manufacturer's recommended grade.
- Oil-lubricated bearings on drivers and gears, as well as oil sumps on gears, have been filled to the required level with the recommended oil.
- All automatic oilers are functioning properly.

When it is necessary to inject water for flushing of the pump bearings, use clean or filtered water. When liquids other than water are handled, they can similarly be filtered and used for injection.

The pressure drop across the filter should be monitored to ensure that the required injection pressure is available.

Vertical pumps with open line-shaft construction are furnished with product-lubricated sleeve bearings. The following provisions should be made for the respective bearings: For bearings lubricated by the pumped liquid) prelubrication with clean water should be provided for all pump bearings above static water level when the distance from the mounting floor to the minimum water level exceeds 15 meters (50 feet).

6.6.5 Driver settings

Follow the instructions of the manufacturer.

6.6.6 Valve settings and operation

Direct-on-line starting

Except for axial-flow and mixed-flow pumps, pumps using squirrel cage induction motors with reduced voltage starting control should always be started with the discharge valve closed or only partially opened.

Warning against closed-valve operation

Warning

Discharge and suction valves should not be closed during operation. The liquid in the pump may boil, with risk of explosion and steam burns to anyone near.



Operation with both valves closed for even brief periods of time is an unacceptable and dangerous practice. It can rapidly lead to a violent pump failure.

If there is any danger of the pump running against a closed discharge valve, install a pressure relief or bypass valve in the discharge pipe to allow for minimum liquid flow through the pump.

Minimum liquid flow through the pump is needed for cooling and lubrication of the pump.

However, brief shut-off operation of most vertical pumps may be necessary. The necessity may arise from system startup or shutdown requirements and is normally met by closure of the discharge valve for the minimum possible time.

Prolonged operation of the pump under this condition may prove harmful to the structural integrity of the pump because of these factors:

- Heat build up resulting in a dangerous temperature rise of the liquid being handled and pump components in contact with it.
- Increased vibration levels affecting the stuffing boxes, mechanical seals and areas with close-running fits.
- Increased axial thrust and resultant stresses in the shafts and bearings.
- Damage resulting from internal recirculation and flow separation.

When a pump has been started against a closed discharge valve, it should be opened slowly as soon as pressure develops at the pump side of the valve. Abrupt valve opening can result in surges damaging to the pump and piping.

Pumps with specific speed over 5000 US units (100 metric units) often have high zero flow horsepower. Running such pumps with the discharge valve closed can result in serious mechanical overloads as well as motor overload.

Water hammer

If there is a risk of water hammer, regulate valve closure time or use relief valves or surge chambers.

We recommend to engage specialized engineering services for water hammer analysis.



Systems must be slowly filled and bled of air before fully the pump discharge valve.

6.6.7 Parallel and series operation

For parallel operation, the pumps should have approximately matching shut off heads. Otherwise, the system operating head may exceed the shut-off head of one or more pumps, resulting in the pump(s) operating with zero output flow. This would have the same effect as operating against a closed discharge valve.

Mismatched shut off heads could also cause one pump to operate below the allowable operating region. For series operation, the pumps should have approximately the same rate of flow characteristics. Since each pump takes suction from the preceding pumps, the stuffing-boxes and all pressure containing components should be designed for the corresponding pressure, and the thrust bearing requirements may also change.

Valve setting at startup

The discharge valve should be set so that the least pump load is imposed upon the driver.

Reduced flow rate/minimum flow discharge bypass

When operating at reduced flow rate, noise levels as well as vibration levels typically increase. This may lead to reduced bearing life and mechanical seal life as well as potential damage to other components.





If it becomes necessary to operate a pump for prolonged periods at flows below the rate specified by Peerless Pump as permissible continuous minimum flow, then a bypass line should be installed from the pump discharge to the suction source. The bypass line should be sized so that the system flow plus the bypass flow is equal or larger than the minimum value specified by Peerless Pump.

Maximum flow

Certain pumps will operate in an upthrust condition beginning at some flow rates greater than the flow rate at best efficiency point. This operating condition should be avoided. Contact Peerless Pump for further information.

Caution

Valve setting during operation

If a suction valve is used, such as in a barrel pump application, the suction valve should be fully opened during operation.

Valve setting at shutdown

The discharge valve should be in the same position as when starting up so that less power is dropped from the line and any sudden pressure surges in the pipe system are avoided.

6.6.8 Condition monitoring

Contact Peerless Pump for more information.

6.6.9 Vibration

Vibration is normally created by the pump driver and flow in the pump, piping and fittings. Contact Peerless Pump for more information on methods of reducing vibration concerns. Vibration levels should be checked at startup and periodically during operation at the design rate of flow.

6.6.10 Performance testing

Once the unit is energized, check operating speed, flow rate, suction and discharge pressure, and power input. While it may not be possible to exactly repeat the factory performance, initial field test data becomes a valuable baseline for future checking to determine possible wear and need to perform maintenance. Vibration levels should be checked for the same reason. Auxiliary piping and gasketed joints should be checked for leaks and proper makeup.

7. Maintenance



Warning
Never do maintenance work when the unit is connected to power.



Warning
Do not attempt to lift the entire pump by the lifting lugs (eyes) of the driver.



Warning
Do not work under suspended object unless you have taken precautions to stop its fall in the event of sling failure

7.1 Schedule

To ensure satisfactory operation of the pumping equipment, frequent inspection and periodic maintenance are required. An inspection and maintenance log should be kept and the inspector is to immediately report any problems. A suggested guide for preventative maintenance for normal applications is

given below. Unusual applications with abnormal heat, moisture, dust, etc., may require more frequent inspection and service.

Item	Action	Frequency
Packing, packing box	Inspect for excessive leakage	First 150 hours of operation, then every 2000 hours of operation or quarterly
Packing, packing box	Adjust gland and replace packing	As necessary
Vibration	Check for change in vibration	Annually
Bearings	Per driver OEM recommendations	Per driver OEM recommendations
Fasteners	Check for loose fasteners	Annually

7.2 Wear rings

If specified, wear rings can be fitted in bowls and impellers. These wear rings provide a close-running, renewable clearance to reduce the quantity of liquid leaking from the high-pressure side to the suction side. These rings depend on the liquid in the pump for lubrication. They will eventually wear so that the clearance becomes greater and more liquid passes in to the suction. This rate of wear depends on the characteristics of the liquid pumped. Badly worn wear rings will result in severe degradation of pump head and flow rate, particularly on small pumps. Examination of wear patterns can provide valuable information in diagnosing pump problems and determining their origin.

7.3 Recommended spare parts

The list of recommended spare parts will depend on factors such as the following:

- Normal supplier lead time when ordering parts.
- If pumping equipment is for use as normal duty or severe duty, and if there is backup pumping while a unit is down for maintenance and parts replacement.

Below is a suggested list of spare parts.

For intermittent or non-critical service

- Stuffing box packing or mechanical seal
- Gaskets and O-rings (complete set)
- Packing gland and studs or gland bolts.

For continuous or critical service (in addition to above)

- Stuffing-box sleeve bearing
- Head shaft (if used)
- Line shaft (1 set)
- Line shaft coupling (1 set)
- Sleeve bearings, stuffing box, line shaft and pump shaft
- Pump shaft
- Impeller lock collets (1 set)
- Bowl and/or impeller wear rings (1 set)
- Lateral bowl wear rings.

7.4 Consumables

Items normally used in the maintenance of pumping equipment may include the following, but depending on the type of unit some items may vary:

- Lubricant (grease or oil)
- Cleaning materials
- Touch-up coating.

7.5 Required tools and fixtures





OLS Vertical Turbine Installation, Operation and Maintenance Manual

Removal of packing is aided by the use of a packing removal tool with a hook or threaded end.

Tools and fixtures for pump disassembly and rebuilding, in addition to the above, may include these items:

- Lifting devices (crane, hoist, lifting chains or straps)
- Impeller beater (to fit the impeller lock collet into impellers on shaft)
- die grinder (to cut out wear rings or remove shaft sleeves)
- work table or fixture for holding pump
- torch (to heat parts to aid in removal)
- measuring equipment (feeler gauges, dial indicator, etc.)

the impeller has either been shrunk-fit onto the pump shaft or has become difficult to remove due to products that are corrosive in nature. If you elect to use heat to remove the part, it must be applied with great care. Before applying heat, ensure any residual hazardous liquid trapped between the two parts is thoroughly drained out to prevent an explosion or emission of toxic vapour. Impeller design varies and so does the amount heat and the duration of heat application required to loosen the impeller.

Contact Peerless Pump for help in removal of impellers.

7.6 Tightening torques

Proper tightening of fasteners is very important. The torque values depend on the size and grade of the fasteners used. The values in the table below apply to non-lubricated parts.

Fastener size	Torque [lb-ft] ([Nm])
5/16-18	11 (15)
3/8-16	20 (30)
7/16-14	32 (45)
1/2-13	47 (65)
9/16-12	69 (95)
5/8-11	96 (130)
3/4-10	155 (210)
7/8-9	206 (280)
1-8	310 (420)
1 1/8-7	480 (650)
1 1/4-7	675 (915)
1 3/8-6	900 (1220)
1 1/2-6	1100 (1495)

When assembling a pump, cross-tighten the screws in order to avoid misalignment, binding and leakage.

7.7 Pump decontamination

Prior to dismantling a pump, make sure that the unit is thoroughly cleaned and there is no remaining contamination left that could cause injury or illness. This is particularly true with pumps used for pumping chemicals and sewage.

The method of cleaning pumps will vary with the design and construction of the pump. In general, the pump should be properly drained and flushed out, and any evidence of contamination removed. Contents of the pump, cleaning materials and washdown materials should be properly disposed of. In addition to thorough cleaning, disinfecting of all surfaces to protect from injury and illness is recommended. During the decontamination and disassembly work to the pump, workers are required to wear protective clothing and equipment to protect from exposure to potentially harmful materials.

7.8 Dismantling



Warning
Drain the pump and isolate pipework before dismantling the pump.



Warning
There may be occasions when a part such as

1. Clear a large area adjacent to the pump as a storage space for pump parts as they are dismantled.
2. Arrange parallel timbers on the ground in the cleared area to support the pump column and shaft sections horizontally.
3. Disconnect the discharge pipe from the discharge head.
4. If the driver is equipped with an oil-cooling system, remove the external tubing or piping used for this purpose.
5. On pumps equipped with an air-pressure water level testing system, remove the gauge and disconnect the tubing connection inside the discharge head. Some pumps have this connection below the base, in which case the tubing will be disconnected later.



Warning
Before opening the terminal box of an electric motor, make sure that the power supply has been switched off.

6. Remove the electrical connection of the motor at the terminal box.
7. For vertical hollow shaft (VHS) drives, remove the driver from the discharge head in the following manner: FIX NUMBERING SYSTEM
 1. Remove the driver cover.
 2. Remove the lock screws, the top shaft adjusting nut, the gib key and the top drive coupling.
 3. Some configuration will require loosening of the coupling from the head shaft to the motor shaft.
 4. Remove the driver mounting screws.
5. Attach the hoist sling to the lifting eyes of the driver and lift it off the discharge head and top shaft as applicable.
6. Place the driver on clean wooden blocks.

For vertical solid shaft (VSS) drives, remove the driver from the discharge head in the following manner: FIX NUMBERING SYSTEM

1. Remove coupling from motor to head shaft.
2. Remove the driver mounting screws.
3. Attach the hoist sling to the lifting eyes of the driver and lift it off the discharge head and top shaft as applicable.
4. Place the driver on clean wooden blocks.
5. Remove adjusting nut and pump halve coupling.
6. Remove the deflector from the pump shaft by sliding it up over the top.
7. Remove the gland retaining bolts or nuts and the two gland clamps, if supplied. Lift off the split gland. Pull out the packing rings, using a packing removal tool or a hooked pointed wire.
8. If the packing assembly includes a lantern ring, a compression spring and a washer, or a bushing, remove these. Be sure to remove any packing rings that might be below the lantern ring.





9. If the packing container is a separate casting (not integral with the discharge head), remove the fasteners in the packing container flange, and lift off the packing container.

10. Remove the gasket.

11. Remove the fasteners or nuts holding the discharge head to the sole plate or to the foundation.

12. Attach the sling to the lifting ears of the discharge head or through the handholes if the head is fabricated, and hoist the entire pump straight upward to bring the discharge head base to a comfortable working height.

NEW NUMBERING SYSTEM? Change to a, b, c...

If the pump has an air line with a connection point below the base, disconnect the line at this time.

Follow the instructions given in the following manner:

1. Remove the discharge head.

2. Remove the top column section using an box clamp.

3. Remove the bearing retainer.

4. Remove the head shaft section.

5. Remove the other column sections, shaft sections and bearing retainers.

6. Pull the bowl assembly from the well or sump.

15. Clean and check all parts.

Refer to bowl assembly disassembly, repair, and assembly instructions for detailed instructions.

16. Check the bearing clearance according to the table in section 5.8 Setting the impeller clearance.

17. Recondition or replace worn parts.

18. If a pump shaft is bent beyond acceptable limits, it should be replaced or straightened. See section 5.5.1 Inspection

7.8.1 Wear ring

Worn wear rings can be replaced to restore hydraulic performance.

7.9 Bowl Assembly NEED TO ADD SOME PICTURES AND MORE DETAILED DESCRIPTIONS.

Caution

Take care not to damage any components and avoid contamination (dirt, debris, moisture, etc.) of the unit.

See section 7.6 Tightening torques for torque values.

1. Arrange parallel timbers on the ground in the cleared area to support the pump column and shaft sections horizontally.

2. Support pump shaft in blocks and rails to protect it from bending or being damaged during the re-assembly process.

3. Check that the shaft is straight per section 5.5.1 and free of nicks and scratches. Remove all burrs and scratches. New number. First impeller setting isn't on the chart.

See dimensions B or C in the table in section 5.8 Setting the impeller clearance for its first impeller setting per pump size.

Check that the scribe line is visible or scribe new line on shaft.

4. If impeller and/or bowl wear rings are required, fit wear rings into the bowl or onto the impeller skirt. Contact Peerless Pump if rings should be pressed or secured to part as needed.

Rings final dimension should provide the clearance E shown in the table in section 5.8 Setting the impeller clearance. If clearance is not achieved, machine rings prior to proceeding.

5. Slide the impeller marked 1 (first stage impeller) or the last impeller removed during dismantling along the shaft. The skirt of the impeller should align with the scribe mark within $\pm 1/8"$ (3 mm).

Note

In performance-tested and multipump assemblies, impeller hubs are to be stamped or paint-marked alphabetically/numerically for relocation purposes. All pumps should be re-assembled in the same position as tested, unless otherwise recommended by a Peerless

Pump.

6. Spread the impeller lock collet with a screwdriver or wedge inserted in the split at the wide end (top) and slide it with the tapered end first along the shaft and into the impeller (opposite end of the impeller skirt).

7. Remove the wedge or screwdriver and remove any burrs left by the spreading tool.

8. Drive the impeller lock collet nut tightly into place with a taper lock hammer/beater. Check that the impeller skirt is still aligned with scribe mark.

9. Fit all lateral seal rings (if supplied or required) into the suction manifold and each intermediate bowl.

10. Slide the sand collar, if supplied, over the bottom of the shaft (larger diameter facing the direction of the bell suction), using the bell suction to push the loose sand collar up towards the eye of the impeller until the impeller skirt is seated firmly against the rubber lateral seal ring, positioning the sand collar in its designated location.

11. Remove the bell suction, leaving the sand collar in position on the shaft.

12. Slide the sand collar an additional $1/8"$ (3 mm) towards the impeller eye, and tighten the set screw in the sand collar. This additional adjustment prevents the sand collar from rubbing on top of the bell suction bearing while in operation.

13. Refit the suction onto the shaft until it the first stage impeller contacts the lateral seal ring.

14. For flanged bowls, place the first bowl on the shaft from the top using care not to damage the threads at the top of the shaft. Move the bowl into position, mating with the suction's male register, matching bolt patterns to fasten bolt flanges together. Check to see if rotating element spins freely.

15. For threaded bowls, place the first bowl on the shaft from the top using care not to damage the threads at the top of the shaft. Slide bowl and slowly engage threads into suction. Thread bowl into suction until tight. Use a chain wrench to ensure complete engagement. Check to see if the rotating element spins freely.

Caution

Failure to tighten the bowls sufficiently can result in loosening of the bowl assembly during operation. This may lead to damage of parts and pump failure.

16. Gently push the pump shaft down until the impeller skirt has bottomed out on the lateral seal ring.

Note

Do not force the pump shaft.

17. Scribe a mark on the pump shaft at the very top of the bowl bearing.

18. Gently pull the pump shaft up in the opposite direction.

19. Measure the distance from bearing to scribe line and compare lateral movement of bowl conforms to the table in section 5.8 Setting the impeller clearance. If lateral is not achieved, dismantle the bowl assembly to determine the issue or contact Peerless Pump.

20. Using a bolt or all-thread and washer, firmly lock shaft and impeller in to place on the suction lateral seal ring.

21. Once it is confirmed that the shaft will not spin or travel, repeat above for installation of intermediate impeller, taper lock bushing and bowls.

22. Every three to four stages, loosen bolt holding pump shaft in place to check that lateral movement has not changed.

23. Make sure that the pump shaft spins freely.

24. Slide the discharge bowl in to position and fasten it to the bowl assembly.

25. Fit the upper sand collar, if supplied, onto the pump shaft until the discharge bowl bearing just contacts.

26. Slide the sand collar about $1/8"$ (3 mm) away from the discharge bearing and tighten the set screw. The additional





OLS Vertical Turbine Installation, Operation and Maintenance Manual

movement prevents the sand collar from rubbing on the upper bowl bearing while in operation.

27. Check that the lateral movement for bowl assembly conforms to the table in section 5.8 Setting the impeller clearance.

28. Make sure that the pump shaft spins freely. See section 5.5 Installation preparations for assembly of line shaft, column, packing container, discharge head and driver.

7.10 Accessories

See the manuals supplied with the accessories.





8. Fault finding (Trouble Shooting)

Note When direct-connected to electric motors, determine whether or not the motor is direct-on-line and receives full voltage.

Fault	Cause	Remedy
1. Discharge pressure too low	a) Speed too low	Check speed/rotation.
	b) System pressure lower than anticipated.	Check the system curve.
	c) Air or gas in liquid.	Check liquid to remove air.
	d) Impeller clearance too large.	<ul style="list-style-type: none"> • Check lateral setting. See section 5.8 Setting the impeller clearance. • Check clearance between wear surfaces.
	e) Impeller damaged.	Check that parts are not damaged.
	f) Impeller diameter too small.	Check specified diameter.
	g) Wrong direction of rotation.	Check rotation.
	h) Excessive clearance between wear surfaces on semi-open impellers.	Check lateral setting. See section 5.8 Setting the impeller clearance.
	i) Leaking joints (well application)	Tighten joints.
2. Insufficient suction head.	a) Suction line drawing air.	Tighten line connections.
	b) Suction lift too high or insufficient NPSH.	Check NPSHA.
	c) Air or gas in liquid.	Remove air/gas from liquid.
	d) Bowl gasket defective.	Check gaskets, tighten fasteners, replace
	e) Clogged strainer.	Clean the strainer.
	f) Excessive well drawdown.	Check well conditions.
3. Noise level increased.	a) Poor alignment of pump. Suction and discharge pipe clamps loose.	<ul style="list-style-type: none"> • Ensure proper alignment of the pump and the driver. • Support the suction and discharge piping. • Check vibration dampers, flexible piping and conduit connectors.
	b) Hydraulic resonance.	<ul style="list-style-type: none"> • Alter the resonant piping. • Change the pump speed. • Insert a pulsation damper on the pump/piping system. • Insert flow straighteners.
4. Insufficient flow.	Pump not primed	Check suction conditions.
	a) System head exceeds shut off head	Check system head curve vs. performance curve.
	b) Speed too low	Check rotation speed
	c) Suction lift too high or insufficient NPSH.	Check NPSHA.
	d) Clogged strainer or impeller.	Clean the strainer and impeller passages.
	e) Wrong direction of rotation.	Check rotation.
	f) Leaking joints (well application)	Tighten joints.
	g) Broken shafting or coupling	Rotate shaft and inspect.
	h) Closed suction valve.	Check suction valve.
	i) Not enough suction head for hot or volatile liquids	Check NPSHA
	j) Foot valve too small;	Check foot valve
	k) Worn or damaged hydraulic parts	Inspect part.
	l) Excessive clearance between wear surfaces on semi-open impellers.	Check lateral setting. See section 5.8 Setting the impeller clearance.
	5 Excessive power required.	a) Speed too high
b) Pump operating outside of the allowable operating region (AOR)		<ul style="list-style-type: none"> • Check system curve • Check valve settings
c) Specific gravity or viscosity of liquid pumped is too high		Check predicted performance based on liquid conditions
d) Bent shaft or rotating element		Check parts and straighten as needed.
e) Stuffing-boxes too tight		Check drip rate of liquid from packing
e) Impeller clearance too small casing rubbing or worn wear surfaces.		<ul style="list-style-type: none"> • Check lateral setting. See section 5.8 Setting the impeller clearance. • Check clearance between wear surfaces.
f) Electrical or mechanical defect in motor		Contact local service center for diagnostics
h) Incorrect lubrication of driver		Check lubrication type and amount



9. Typical Parts list and sectional drawing

Pos.	Description
2	Impeller
6 not pointing correctly	Shaft, pump
8	Ring, impeller (optional)
10	Shaft, head (VHS)
12	Shaft, line
13	Packing
15	Bowl, discharge
17	Gland, packing
29	Ring, lantern (optional)
39	Bearing, sleeve
40	Deflector
55	Bell, suction
63	Bearing, stuffing box
64	Collar, protecting
66 not pointing correctly	Nut, shaft adjusting
70	Coupling, shaft
83	Stuffing box
84 not pointing correctly	Impeller lock collet
101	Pipe, column
129	Sole plate
131	Guard, coupling (not shown)
187	Head, discharge
189	Flange, top column
191	Coupling, column pipe
193	Retainer, bearing, open line shaft
197	Case, discharge (not shown)
199	Bowl, intermediate (not shown)
203	Case, suction (optional, not shown)
205	Barrel or can, suction (optional, not shown)
209	Strainer (optional, not shown)
211	Pipe, suction (optional, not shown)
213	Ring, bowl
N/A	Lateral ring

MUCH BETTER DRAWING

10. Disposal

This product or parts of it must be disposed of in an environmentally sound way.

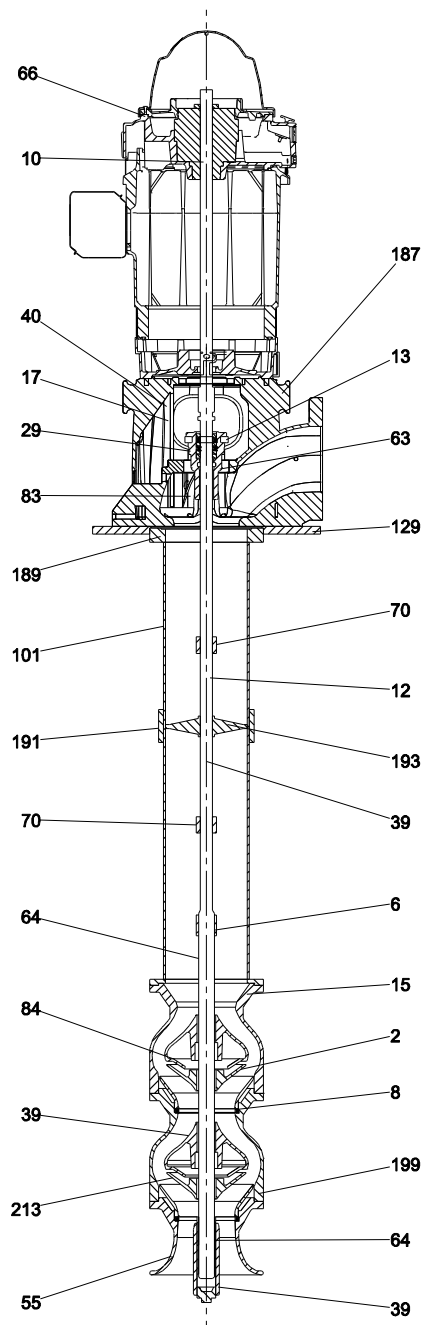

Fig. 17 Typical sectional drawing

TM051471



Peerless Pump Company

2005 Dr. Martin Luther King Jr. Street
Indianapolis, IN • 46202

Phone - 317.925.9661 • Fax - 317.924.7388

www.peerlesspump.com • www.labour-taber.com

