

Installation
Operation &
Maintenance

***LaBour LHLA & LPLA
SELF-PRIMING
CHEMICAL PROCESS PUMPS***

<u>Contents</u>	<u>page no.</u>
1. Preface -----	1
2. Check Points on Arrival -----	1
3. Safety -----	1
4. Storage -----	2
5. Installation and Piping -----	3
6. Precautions for Operation -----	4
7. Maintenance Check Points -----	5
8. Disassembly -----	7
9. Assembly -----	8
10. Parts Ordering -----	9
11. Appendix	

- Sectional Drawing
- Parts And Material List
- Fastener Tightening
- Oiler Instructions
- Coupling Alignment
- Nozzle Loading
- MAX-LIFE Seal Chamber
- Vibration Monitoring
- ANSI B16.5 & 16.42 FLANGES

1

Preface

Thank you for purchasing a LaBour Chemical Process Pump, LHLA / LPLA Series. The LHLA / LPLA Series is a line of centrifugal pumps available in a variety of materials. These pumps are an ideal choice for applications involving the transfer of chemicals where a self-priming pump is required. We suggest that you read this instruction manual carefully in order to ensure full understanding and correct handling of this pump. The instructions and recommendations contained in this manual are intended for personnel trained in installation, operation and maintenance of centrifugal pumps. It should be understood that the information enclosed will not relieve the operator from the responsibility of exercising normal good judgment in the care and operation of this equipment.

LaBour Pumps assumes no responsibility for the design of foundations, piping systems or other manufacturers equipment. LaBour recommends that a specialist in the design and installation of pumping systems be consulted.

2 Check Points on Arrival

- *Does the nameplate correspond to what you ordered?
- *Are all the accessories supplied?
- *Have any components been damaged in transit?

- *Have any of the nuts and bolts become loose?
- *Can the shaft be turned easily by hand?
If heavy resistance is felt, or the pump does not turn at all, this means that the equipment has been damaged in shipping.

If any shortage or damage is found, it should be immediately called to the attention of the local agent of the delivering carrier, and proper notation be made by him on the freight bill. This will reduce potential controversies when claims are filed with the carrier. No claims will be considered thirty (30) days after receipt of shipment.

3 Safety

A centrifugal pump, like other high speed or pressure retaining devices, can be dangerous if misused. This danger is greatly increased when the pump is handling corrosive, toxic, or other hazardous liquids. Every caution must be taken against accidents that may endanger property or life.

Electrical Dangers

Proper consideration must be given to the dangers associated with the presence of electric currents. It is essential that safety devices, such as removable fuses and safety lockouts be used to guard against electrical shock or accidental pump starting.

Guards

Carefully check that all guards, plugs, screws, nuts and other parts that may have been removed during installation or maintenance, have been replaced before energizing the power or filling the pump.

Pump Application

This pump has been engineered for a particular application and operating point. Before using this pump in another service, LaBour must be consulted to make sure that the pump will safely handle the application.

Handling

Never lift the entire pumping unit by attaching eyebolts to the motor or the pump. Customer supplied eyebolts should be attached to the four anchor bolt holes (provided in the baseplate as shown).

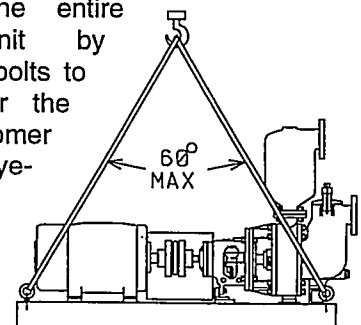

The total included hitch angle should not exceed 60°.

Handling - continued

!-CAUTION-!

Any eyebolts attached to the pump or motor are sized for safe handling of that individual piece of equipment only. Lifting of the entire unit from these eyebolts must not be done.

Care must be exercised when handling this equipment to avoid damage or misalignment due to rough treatment. Be certain that the lifting straps do not press against any vulnerable components, such as seal flush lines, gauges or oilers. Components like these could easily be bent or damaged from the slings.

4 Storage

Short Term (less than 4 months)

If the pump is to be stored prior to installation, a protected environment is required. The unit should be stored in a dry level area. Motor windings must be protected from excessive moisture absorption.

The pump must be drained of any liquids that might have entered or condensed during shipment. This is required to prevent damage due to freezing. Attention must be paid to draining the casing, seal and gland.

- Repair any damage to the flange covers (ductile iron casing flanges should be given a heavy coat of rust preventative, such as Tectyl 506 before recovering).

Long Term (greater than 4 months)

STORAGE AREA:

Sheltered storage is required to protect the pumps from the effects of the elements. Pumps must be properly protected from moisture, dirt and physical damage during storage. The unit should be stored in a dry level covered area. A concrete floor is desirable and the storage area should be well ventilated.

PUMPS:

The pump must be drained of any liquids that might have entered or condensed during shipment. This is required to prevent damage due to freezing.

Machined surfaces of ductile iron and steel components should be given a heavy coat of rust preventative, such as Tectyl 506.

For a pump with a ductile iron casing, a powdered form of "Volatile Corrosion Inhibitor" such as Shell VPI 260, or Cortec VCI-309, should be placed into the pump through the suction flange. The suction and discharge flanges must be covered with a sturdy plastic flange cover and taped with waterproof Duct tape to seal from the atmosphere.

Pumps with alloy casings should be stored with plastic screens taped over the suction and discharge flanges to allow the pump to "breathe". The pump must be protected from liquids entering through the screens!

Fill the bearing housing with 10 weight turbine grade oil to the top of the oiler mounting base. Fill and install the oiler bottle. Manually rotate the shaft several times in the clockwise (when viewed standing at the drive end of the pump) direction. Repeat this shaft rotation at least once every month. Note the position of the shaft keyway to make sure that the shaft is stopped about 180 degrees from the last storage position.

Drain the housing and fill with fresh oil to the level shown in the appendix before running.

MOTORS:

Motors must be stored in a clean dry area protected from extremes of temperature, moisture, shock and vibration. Storage temperatures of 50 - 120 °F. with a maximum relative humidity of 60% must be observed.

Motor windings must be protected from excessive moisture absorption. Do not wrap or cover the pump or motor in plastic as this will prevent condensation moisture from escaping and damage to the unit will be accelerated. All motors equipped with heaters are to have the heaters connected and operating.

Machined surfaces should be given a heavy coat of rust preventative, such as Tectyl 506.

Manually rotate the shaft several times. Repeat this shaft rotation at least once every month. Note the position of the shaft keyway to make sure that the shaft is stopped 180 degrees from the last storage position.

All condensate drains must be open and the drain must be at the lowest point of the motor.

After six months in storage additional grease must be added to the bearings, purging some of the old grease from the cavity.

If the motor has been stored more than twelve months, all old grease must be purged from the bearings and replaced by new grease.

Motor windings are to be "MEGGED" after the motor is removed from long term storage. The resistance of the stator windings must be at least 1.5 Megaohms. If this resistance is not achieved, the motor manufacturer must be consulted before proceeding.

Refer to the motor I.O.M. for additional instructions.

MECHANICAL SEAL:

Seal cavity and gland must be dry before the pump is put into storage.

Plug all openings to the seal cavity and gland. Mask the clearance between the gland and the shaft to prevent dirt and debris from entering the seal cavity.

Turn the shaft several rotations each month.

5 Installation and Piping

Installation

COUPLING ALIGNMENT:

The coupling halves should be disconnected and not reconnected until installation of the pumping unit is complete and the motor rotation has been checked and found to be correct.

Pump and motor were aligned at the factory, but shifting of the equipment during shipping and handling and flexing of the base makes field alignment mandatory. Several alignment checks are required during installation to prevent bolt binding.

Coupling realignment is required after:

- 1 - leveling base on foundation
- 2 - attaching suction and discharge piping
- 3 - grouting base and tightening anchor bolts
- 4 - after running one week and while at normal operating temperature

See the coupling manufacturer's recommendations for detailed coupling alignment instructions.

FOUNDATION:

The pump should be installed on a concrete foundation. If this is not possible, the base can be installed on a steel frame, providing the frame is stiff enough to prevent vibration during operation.

Place a level on the surface of the base and on the discharge flange of the pump, and check the level in all directions. When using a concrete foundation, place metal shims at four points between the concrete surface and lower surface of the base in order to level the pump. Shim under the base so that the level indicates a horizontal position.

Check coupling alignment to confirm that final alignment can be achieved. Then, grout the pump in with non-shrink epoxy grout so that the foundation and pump base are joined together as a single unit.

Recheck coupling alignment after the grout has set and the anchor bolts have been tightened. See coupling manufacturer's recommendations for detailed coupling alignment instructions.

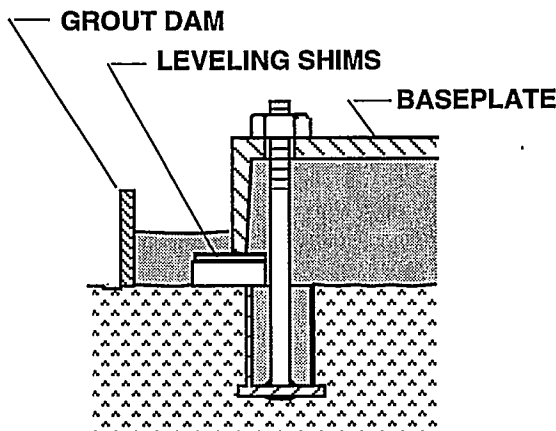

Piping

NOZZLE LOADS:

(see appendix for chart of loads)

In accordance with Hydraulic Institute Standards, "It is desirable to support and restrain both the suction and discharge pipes near the pump casing. In installations involving large temperature variations, expansion of the connected piping may subject the pump nozzles to significant forces and moments. If this condition is unavoidable, each such application should be referred to the pump manufacturer for approval."

SUCTION PIPING:

For a suction lift application, the suction piping must be as short as possible. Any long lengths of horizontal piping will cause priming problems.

Do not oversize the suction pipe. The pipe should be the same size as the nominal size of the pump suction flange. This will prevent priming problems due to excessive amounts of air.

Minimize the number of flange fittings and joints to avoid potential leak areas. Where practical, welded joints are preferred to reduce emissions / leaks.

The suction pipe should be hydrostatically tested for leaks at initial installation, and every twelve months thereafter. Air leaks on the suction side of the pump will prevent the pump from holding prime and could result in damage to the pump.

When possible a suction side valve should be eliminated. When a valve can not be avoided, it must be installed in a horizontal position or facing downward in order to prevent accumulation of air. Be sure to keep the valve fully open when the pump is running or during priming.

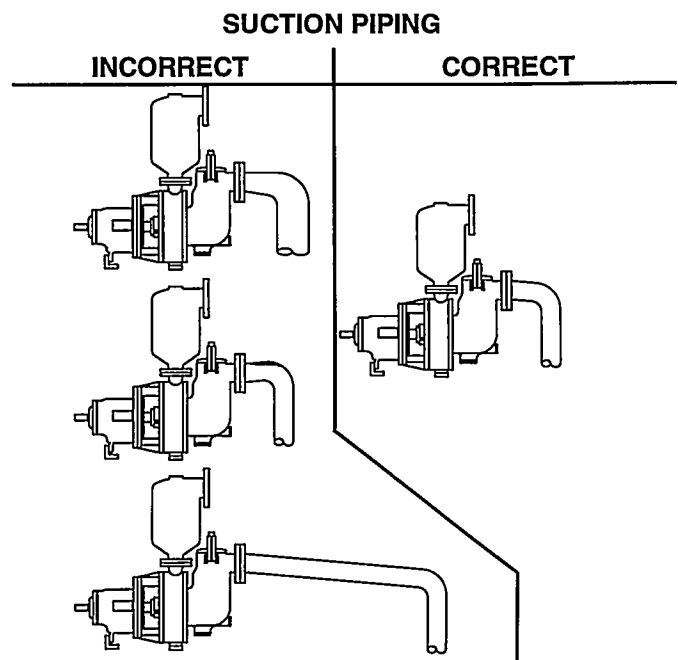

Piping - continued

Make bend sections as gentle as possible and keep the number to a minimum. Minimize the number of flange joints.

Arrange pipe so that there is an upward incline to the suction side of the pump (approximately 1/50 slope) in order to prevent air collecting in the piping.

For parallel pump operation, use independent suction piping to avoid priming problems.

DISCHARGE PIPING:

Discharge piping must provide for free exhausting of air and vapors during the priming cycle.

Do not undersize the diameter of the discharge piping. Provide air vent valves where necessary since accumulation of air has an adverse effect even when it occurs on the discharge side.

When the discharge piping has a vertical leg, it is best to install check valves to prevent reverse rotation during pump shutdown and also to avoid water hammer. **Since there is no means for air to escape during operation, air vents below the check valves are required.**

If the discharge piping has a vertical leg followed by a dropping of the pipe to form a siphon, the highest part of the discharge pipe must not exceed the shutoff head of the pump.

6 Precautions for Operation

Start-Up

Rotate the motor shaft manually and confirm that it turns without resistance.

Clean the inside of the suction piping, as dirt and scale may have entered the piping during installation which could cause pump damage.

Confirm rotation direction of the motor (correct direction shown by arrow on pump bearing housing cover).

!~CAUTION~!

Rotation must be checked with the coupling halves disengaged. This must be done to prevent pump damage due to being driven in the reverse direction.

Open the valve on the suction pipe line fully. Add priming charge to pump through the trap cover. The priming charge liquid must be compatible with the process and the liquid being pumped.

!~CAUTION~!

Pump must be filled with a liquid before it is started or seal will be damaged from running dry. Double or tandem seals, must be flushed with clean pressurized fluid in the seal cavity

After the initial priming charge has been added, the pump will retain enough liquid for subsequent starts.

Rotate the motor by hand in both directions to make sure that all air has been expelled from the seal chamber. Start external seal flush (if required for single seal, mandatory for double and tandem seals).

Start the pump with the discharge valve open or partially opened. **This must be done to permit free exhausting of air during the priming cycle.** While the pump is priming the amperage draw and the discharge pressure will be very low. The discharge pressure will rise sharply when the pump primes. Adjust the discharge valve until the specified pressure and/or flow has been reached.

!~CAUTION~!

If the pump fails to prime after **FOUR** minutes of operation, the pump must be shut down & the cause of the priming problem fixed. This must be done to prevent pump damage from over heating of the priming charge.

Use of LaBour's "Dual Trip AC Current Sensor" is recommended to provide protection for the pump from running dry or from failure to prime. The standard unit is designed to trip the pump due to under or over current draw. The time delay for under current must be set to allow the pump to get through its normal priming cycle. An auxiliary trip input is available for those customers wishing additional pump protection by the addition of a vibration or a temperature detector. See separate manual for additional information.

Checks During Operation

Noise Check: Sucking in of air or solids from the suction piping often gives rise to abnormal noise and vibrations. Pulsation of the suction gauge reading is often apparent when a vacuum leak exists.

Vibration Check: Precautions are required in the case of vibration caused by cavitation, or poor installation. Be sure to adjust the discharge flow rate with the valve on the discharge side only. Do not close the suction valve.

Shaft Seal Leakage: Visual leakage from a mechanical shaft seal of more than ten drops per minute is abnormal and must be investigated. See seal section.

Stopping Operation

- Under normal conditions, the discharge valve must be closed before stopping operation of the pump. Pump operation with either the suction or discharge valve closed, must be limited to no more than one minute.
- When operating under pressurized suction conditions, close the suction valve after stopping operation.
- When the pump stops due to a power failure during operation, first turn off the power switch and close the discharge valve manually.

Freeze Damage

- Special care is required during the cold seasons since retained liquid will freeze, upon which it will expand, causing cracks and other serious damage.

Other Precautions

- Installed spare pumps should not be left unused for long periods of time, but utilized periodically to confirm that they are ready for use when needed.
- Do not allow dry operation of the pump. Dry running will cause seal damage.
- Operation must be restricted within the limits shown on the performance curve or as specified by LaBour. Do not use with an insufficient or excessive flow rate.
- Oil level must be checked prior to start up. See appendix for detailed instructions.

7 Maintenance Check Points

Varying operating conditions make it difficult to recommend a single maintenance schedule. Good operating records are required to determine the particular maintenance schedule best suited for an individual pump application. Records of pump vibration spectrum, hours of operation, flow rates, suction and discharge pressures, motor amperage, etc., is the best way to predict when maintenance will be required. An individual log of pump operation and maintenance is the best means of record keeping.

For a non-critical, non-severe service, the following maintenance schedule is recommended:

Weekly Check

- *Level of suction sump and condition of suction screen
- *Suction and discharge pressure, note and record
- *Record motor amperage
- *Record pump and motor vibration
- *Note any unusual noise
- *Note the process temperature
- *Record bearing temperature
- *Check for leakage from the flanges, casing gasket, mechanical shaft seal
- *Pumps with compression type shaft packing should have the gland adjusted such that 10 - 30 drops per minute of leakage occurs

**SEMI-ANNUAL MAINTENANCE CHECK-UP
(REQUIRES PUMP REMOVAL AND DISASSEMBLY)**

Parts	Check Points	Countermeasures / Replacement
Casing Trap & Seperator	<ul style="list-style-type: none"> • Erosion damage • Impeller rubbing damage • Surface deposits 	<ul style="list-style-type: none"> • Replace if depth exceeds 0.06 inch • Replace casing if depth exceeds 0.06 inch. • Replace worn bearings (if the cause of the rub). • Clean
Seal Chamber (Stuffing Box)	<ul style="list-style-type: none"> • Erosion or rubbing damage • Surface deposits 	<ul style="list-style-type: none"> • Replace if depth exceeds 0.06 inch • Clean
Impeller	<ul style="list-style-type: none"> • Erosion or wear • Surface deposits • Cracks 	<ul style="list-style-type: none"> • Replace if depth exceeds 0.05 inch • Clean • Replace
Shaft	<ul style="list-style-type: none"> • Wear due to rubbing of packing • Surface deposits • Runout 	<ul style="list-style-type: none"> • Replace if grooves are deeper than 0.010 inch • Clean • Use if less than 0.003 radial or 0.002 axial at impeller mount surface

Packed Stuffing Box

- Pumps equipped with compression type packing require particular attention. The stuffing box space provides for 3 rings of packing at the impeller end of the box, followed by a lantern which must communicate with the flush tap, followed by two rings of packing, followed by the the gland.
- The stuffing box must be thoroughly cleaned before packing is placed in it. Packing must be cut so that he ends just meet when wrapped around the shaft. The joints should be staggered by 120° as each successive ring of packing is added.
- Press each ring of packing firmly but not tightly into the box. Install the gland and finger tighten the gland bolt nuts. The gland is designed to engage the bore of the box. If this is not possible, one ring of packing should be left out during the break in period for the new packing.
- The gland must be adjusted such that 10 - 30 drops per minute of leakage occurs. If the gland has been over tightened, the box will have to be repacked.
- Packing wear will eventually result in the gland bot-toming out against the box. When this happens it is acceptable to add one additional ring of packing. The next time this happens, the stuffing box must be repacked.
- A break in period of about 20 hours of operation is required before new packing can be adjusted down to the 10 - 30 drops per minute leakage.

- Grease lubrication or flushing with a compatible liquid through the lantern ring will greatly increase the life of the packing.

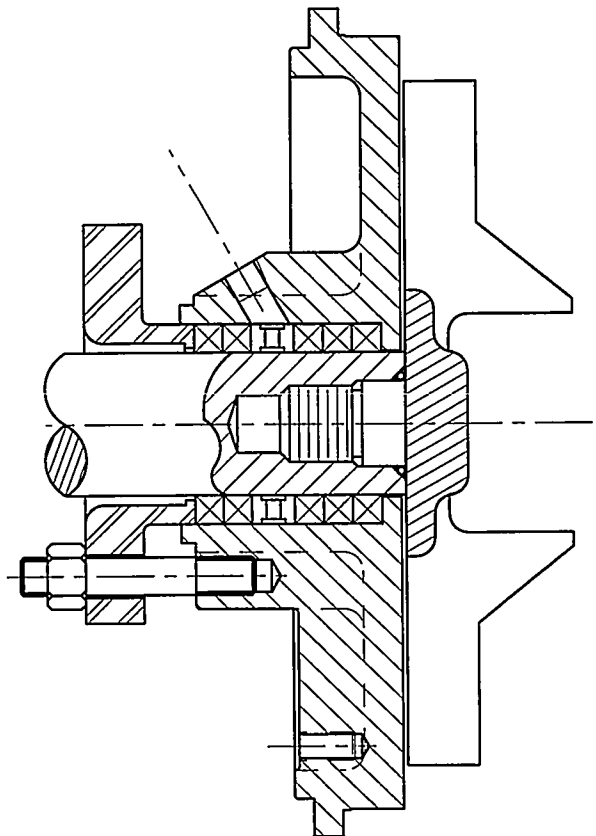

8 Disassembly

- The following is the recommended step by step procedure for dismantling the pump for inspection and repair. The numbers () referred to in this procedure are the same as those shown on the Sectional Drawing included in the appendix.
- Before unbolting any flanges, match mark in order to ease the reassembly and insure proper realignment.

Removing Pump Assembly

- Since the LHLA / LPLA series of centrifugal pumps are a back pull out design, most normal repairs and inspections can be carried out without removing the pump casing from the baseplate or removal from the suction and discharge piping. If this situation is thought to be the case, skip this section and go to "Removing Pump Rotating Element".
- If it is determined that major pump components must be repaired or replaced, then the entire pump assembly should be removed from its baseplate.
- Lock out motor electrical breaker to prevent accidental starting of motor. Remove coupling guard. Remove coupling spacer. Drain the oil from the Bearing Housing (223), noting if any metallic particles are present. Remove the oiler assembly.

!~CAUTION~!
The pump must be drained of any hazardous liquids before it is removed. Since small pockets of liquid will always be retained in various pump cavities, care must be taken to protect people working on the pump!

Use an overhead crane to carry the weight of pump while it is being lifted off of the baseplate. Using choke slings around the bearing housing and the suction flange is the best way to hitch the pump and to provide for a safe captive vertical lift. Move the pump to a maintenance area for further dismantling.

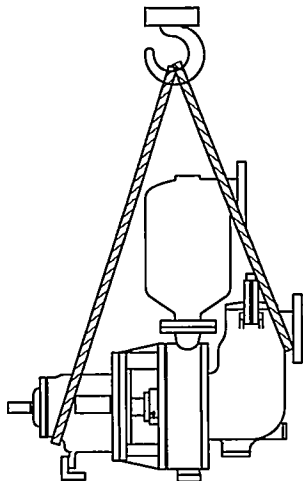

Removing Pump Rotating Element

- Since the LHL / LPL series of centrifugal pumps are a back pull out design, most normal repairs and inspections can be carried out without removing the pump casing from the baseplate or removal of the suction and discharge piping.
- Lock out motor breaker to prevent accidental starting of motor. Remove coupling guard. Remove coupling spacer. Drain the oil from the Bearing Housing (223), noting if any metallic particles are present. Remove the oiler assembly.

!~CAUTION~!
The pump must be drained of any hazardous liquids before the rotating element is removed. Since small pockets of liquid will always be retained in various pump cavities, care must be taken to protect the people working on the pump!

- Remove nuts fastening the Adapter (218) to the Casing (200). Use an overhead crane to carry the weight of rotating element while it is being pulled out of the casing. Move rotating element to a workbench for further dismantling.

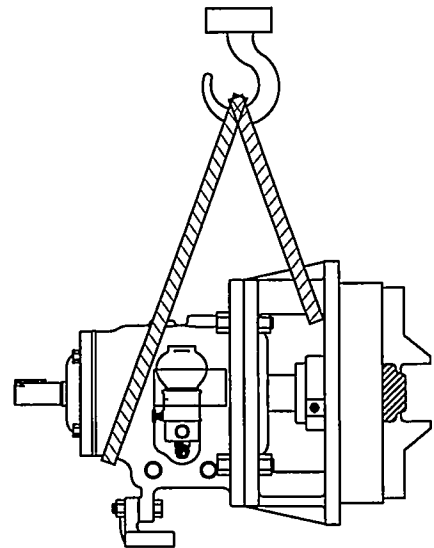

Dismantling Rotating Element

- Use an adjustable wrench to hold shaft from turning (coupling hubs are normally furnished with flats for this purpose). Use a rubber mallet to loosen the Impeller (206), turning in a counter-clockwise direction. Remove impeller.
- Remove the gland nuts and loosen the Gland (212).
- Remove the two Capscrews (211) fastening the Stuffing Box Cover (210) to the Adapter (218). Remove the stuffing box cover. No further dismantling of pump is required to repair or replace the mechanical seal.
- The rotating element is now dismantled. Inspection of all normal wear components can be carried out in this state. Reference section 7 of this manual.

Disassembly - continued

Dismantling Bearing Housing

- Remove the Gland (212) and mechanical seal from the shaft.
- Remove the Adapter (218). Push the Shaft (226) and Bearing Cartridge (232) assembly from the Bearing Housing (223). Remove the bearing retaining Snap Ring (SR) and press off the cartridge. Remove the thrust bearing Locknut (229) and Lockwasher (230). Press the Bearings (225 & 228) off of the Shaft (226).
- Press the oil lip seals (224 & 235) out of the Adapter (218) and the Bearing Cover (232).

9 Assembly

The numbers () referred to in this procedure are the the same as those shown on the Sectional Drawing enclosed.

Make sure that the flange match marks are properly aligned when the components are reassembled.

All components must be thoroughly cleaned before they are assembled. Carefully inspect all gasket surfaces to make sure that they are free of any nicks or scratches that might impair their sealing.

Replace all gaskets, lip seals, o-rings, etc., when reassembling pump.

Bearing Housing Assembly: Insure all parts, the work bench area, and all required tools are clean and free of grit, rust, dirt, and any other debris.

Install new labyrinth or lip seals, gaskets or o-rings in any adapters, bearing covers or bearing cartridges. The lip of any oil seals must be pointing toward the bearing (any garter springs must face towards the bearing). Lubricate oil lip seals and o-rings with grease or a light oil.

Blow air through any grease or oil passages to assure that they are free of debris. Install grease fittings where required and pump with grease until all passages are filled with clean grease. Cover components to keep clean.

Install oil flinger (as required for oil lubrication) at the position shown on the assembly drawing.

Clean any required locknuts and washers. Apply oil to threads and trial assemble to the shaft.

Bearing Assembly: Do not remove the bearings from their original packing until the shaft and all other required components are ready for assembly. It is not necessary to remove the light coating of preservative which is on the bearing to prevent corrosion in storage.

Inspect the bearings and **compare** to the **assembly drawings** and any **notes** on the **bill of material** to determine the proper **mounting position**

and **location** of any **shields or seals** .

ANGULAR CONTACT- Only specially match ground bearings are suitable for mounting in pairs. The **bearing markings** must **match** the **bill of material**. The outboard thrust bearings (228) must be installed **"BACK TO BACK"** (as a set of two bearings with the large portion of the outer race on one bearing facing the large portion of the outer race on the other bearing).

Heat new anti-friction Bearings (225 & 228) to 180 °F (Note - bearings with integral lip seals can not be heated above 150° F or the seal may be damaged). While bearings are hot, install on the Shaft (226) and secure with the new lock washer (230) and Locknut (229) hand tight. Completely wrap the bearings with oil paper to keep clean.

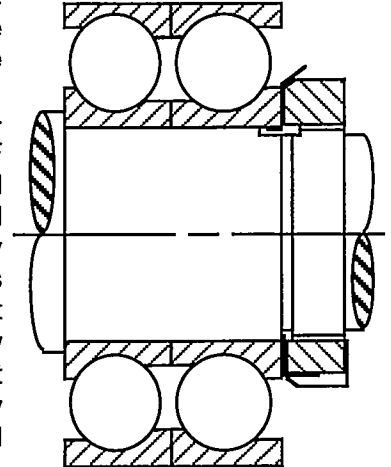

When bearings and shaft are cool, tighten the bearing locknut until lower bearing race is solid against the shaft shoulder. While the locknut must be tight, excessive tightening may damage the bearing race or the retaining shoulder on the shaft. Hand tightening with a spanner wrench is the best method available. Bend a locking tab of the lockwasher into a slot on the locknut with which it aligns. Completely cover the bearings to keep them clean.

PUMPAC Bearings: Install on shaft (in the same manor as normal angular contact bearings) making sure that the "V" marked on the outer races of the set of two bearings aligns and points toward the impeller end of the shaft. Wrap the bearings with oil paper to keep clean.

Oil Lubricated Pumps: Press the bearing/shaft assembly into the Bearing Cartridge (232) and assemble the bearing Snap Ring (SR) to locate the thrust bearings. Assemble the bearing/shaft/bearing cartridge sub-assembly into the bearing housing (223).

Assembly of covers, plugs, adapters, etc., must be completed quickly to prevent contamination of bearings with dirt and debris. See instructions in the I.O.M. manual for type of oil, installation of oilers and filling procedures.

Grease Lubrication: The bearings are to be hand packed lubricated with Magnalube G (Carleton-Stuart Corporation, Long Island City, NY) grease or equal. Accrolube is an equivalent grease. Enough grease must be worked past the balls and the cage such that at least 90% of all air space within the bearing has been filled with clean grease.

Press the bearing/shaft assembly into the Bearing Cartridge (232) and assemble the bearing Snap Ring (SR), with the gap of the Snap Ring straddling the oil return groove in the Bearing Cartridge, to locate the

thrust bearings. Assemble the bearing/shaft/bearing cartridge sub-assembly into the bearing housing (223).

Assembly of covers, plugs, adapters, etc., must be completed quickly to prevent contamination of bearings with dirt and debris.

Before starting, several strokes of grease should be added through the grease fittings.

Setting Impeller Clearance (New Parts):

Replacement of the Stuffing Box Cover (210), Bearing Housing (223), Adapter (218), Shaft (226) and or Out-board Bearing (228) may necessitate readjustment of the running clearance (0.015" - 0.025") between the impeller blades and Stuffing Box Cover.

Resetting of the impeller clearance can be done with the drive unit disassembled from the casing. Gently tap the shaft assembly forward until the bearing cartridge touches the face of the bearing housing. Measure the protrusion of the shaft beyond the Stuffing Box Cover (0.000" - 1.000" depth micrometer is preferred measurement tool). Whatever amount this measurement exceeds 0.020" will be the total amount of shims to be installed between the bearing cartridge and the rear face of the bearing housing.

Move shaft assembly back toward coupling end. Install proper thickness of shims (each of the four shim packs must be uniform to within 0.002" of each other). Tighten the bolts locating the shim packs. Measure and record the protrusion of the shaft assembly beyond the stuffing box cover (should be 0.015" - 0.025"). [See Section 7-"Maintenance Check Points" for how to set the impeller clearance with the pump in place].

Shims - Bearing Cartridge: Shim packs are the recommended way to set the impeller position (each of the four shim packs must be uniform to within 0.002" of each other). When shims are not readily available, it is possible to use the two jackscrews supplied with the bearing cartridge in order to set the impeller position. Care must be taken to make sure that the each jackscrew is equally loaded to prevent "cocking" of the cartridge. A lock nut should be added to the jackscrew to prevent loosening.

Mechanical Shaft Seal Installation: Installation of a mechanical shaft seal requires special care to keep parts extremely clean and to prevent damaging brittle sealing surfaces. A drawing showing the assembly methods and setting dimensions is required before the seal can be installed. **This drawing must be for the particular seal being installed!**

If you do not have the correct seal drawing, copy down the seal information and pump serial number

from the nameplate attached to the pump and call LaBour Engineering at 317/925-9661 to request that a drawing be sent.

Install seal, gland and stuffing box cover in accordance with the seal drawing.

Pump Rotor Element Assembly: Fasten the stuffing box to the adapter using Capscrews (211) as shown on the sectional drawing.

Replace the impeller Gasket (209) and screw the impeller into the end of the shaft. Lock the coupling end of the shaft to prevent the shaft from turning and use a rubber mallet to firmly tighten the impeller. Recheck clearance between impeller and stuffing box (should be 0.015" - 0.025") with feeler gauges.

Final Pump Assembly: Place Casing Gasket (204) onto the Stuffing Box Cover (210). Assemble rotor into the pump Casing (200) being careful not to pinch the gasket.

Uniformly torque casing studs and nuts (205) in a cross-flange pattern. Increase the torque value in increments of about 5.0 lb-ft until reaching a SAE Grade 2 dry bolt torque (torque values listed in appendix).

Recheck coupling alignment (see coupling information in appendix)

Install oiler and fill bearing housing using oiler. Detailed instructions for installation of oiler and acceptable grades of oil are included in the appendix.

The pump is now assembled. Please review all items discussed in **Section 6 - Precautions for Operation** before starting pump.

10 Parts Ordering

Order parts by identifying the particular component from the Sectional Drawing included in the appendix of the instruction manual. The order should reference the "Piece Number" shown on the drawing and the "Part Name" given on the "Parts & Material List" also included in the manual. The order should include the pump serial number (found on the nameplate attached to the pump) to assure that the correct metallurgy part is supplied.

THIS PAGE INTENTIONALLY LEFT BLANK

APPENDIX

1. Sectional Drawing
 - 1.1 LHLA pump Sectional Drawing
 - 1.2 LPLA pump Sectional Drawing
2. Parts and Material List Form
3. Fastener Tightening
4. Oiler Instructions
 - 4.1 Oiler Installation Guide
 - 4.2 Oil Leakage Trouble Shooting Guide
 - 4.3 Recommended Bearing Lubricants
5. Coupling Alignment Specifications
6. Nozzle Loading
7. MAX-LIFE Seal Chamber
8. Vibration Monitoring
9. ANSI B16.5 & B16.42 FLANGES

This is an LPLA Separator

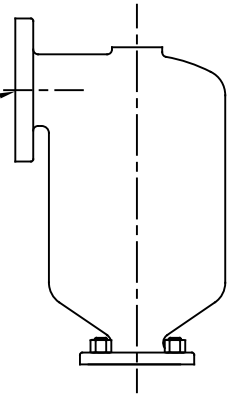

This is an LHLA Separator
ONLY on size 10 and 12 LHLA

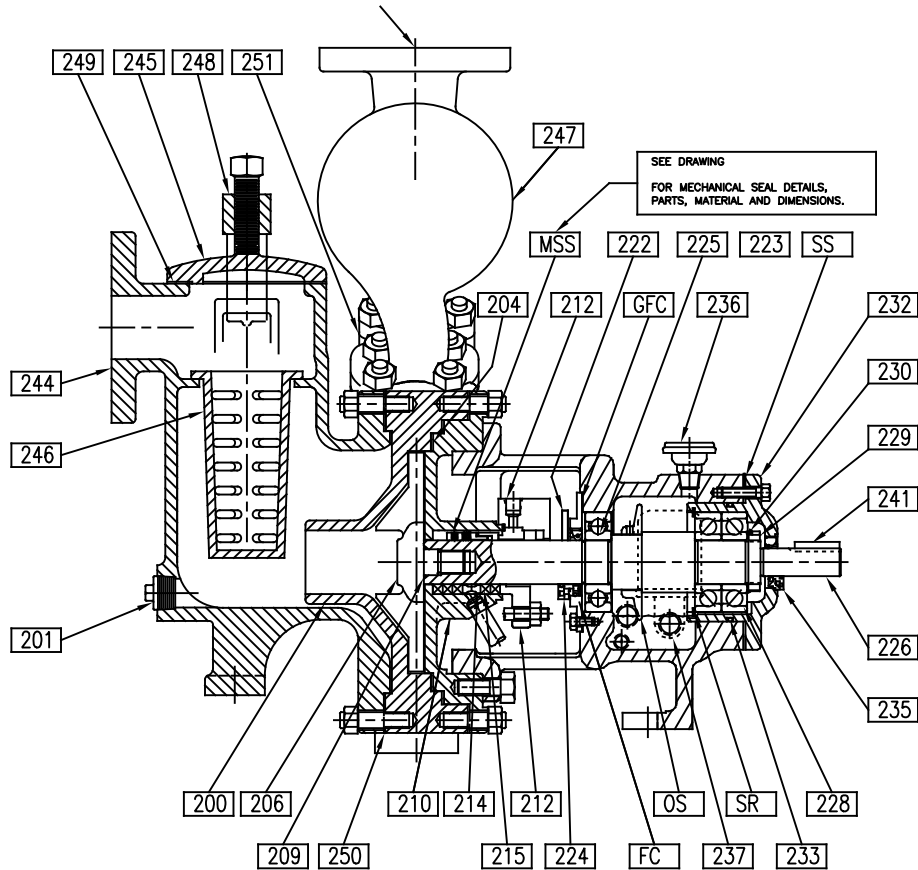

PARTS AND MATERIAL LIST

PC. NO.	NO. REQD	PART NAME	WET END MATERIAL										
			DUCTILE IRON			304	316	ELCOMET K	R-55	TI	NICKEL	Y-17	Y-30
*	200	1 CASING	D.I.	D.I.	D.I.	304	316	K	R-55	TI	NICKEL	Y-17	Y-30
o	201	1 CASING DRAIN PLUG	D.I.	D.I.	D.I.	304	316	K	R-55	TI	NICKEL	Y-17	Y-30
*	206	1 IMPELLER	316	K	R55	304	316	K	R-55	TI	NICKEL	Y-17	Y-30
*	210	1 STUFFING BOX COVER	D.I.	D.I.	D.I.	304	316	K	R-55	TI	NICKEL	Y-17	Y-30
	226	1 SHAFT	316	K	R-55	304	316	K	R-55	TI	NICKEL	Y-17	Y-30
o	242	1 SHAFT SLEEVE (OPTIONAL)	316	K	R-55	304	316	K	R-55	TI	NICKEL	Y-17	Y-30
*	244	1 TRAP	D.I.	D.I.	D.I.	304	316	K	R-55	TI	NICKEL	Y-17	Y-30
*	245	1 TRAP COVER	D.I.	D.I.	D.I.	304	316	K	R-55	TI	NICKEL	Y-17	Y-30
*	246	1 STRAINER	D.I.	D.I.	D.I.	304	316	K	R-55	TI	NICKEL	Y-17	Y-30
*	247	1 SEPARATOR	D.I.	D.I.	D.I.	304	316	K	R-55	TI	NICKEL	Y-17	Y-30
	248	1 COVER CLAMP	304SS										
	212	1 GLAND	AS SPECIFIED										
	204	1 CASING GASKET	Sepco-6234 (Gylon, Teflon, etc., Optional)										
	209	1 IMPELLER GASKET	TEFLON										
	MSS	1 MECHANICAL SEAL	Optional										
	243	1 SHAFT SLEEVE PIN	316										
	214	1 LANTERN RING	TEFLON										
	215	1 STUFFINGBOX PACKING	SEPCO-ML4002 (OTHERS OPTIONAL)										
	OS	1 OIL SLINGER	STEEL										
	SR	1 BEARING RETAINING RING	N-5002-316 (TruArc)										
	222	1 DEFLECTOR	NEOPRENE										
	223	1 BEARING HOUSING	Ductile Iron										
	224	1 INBOARD OIL SEAL	137-244-12										
	225	1 INBOARD BEARING	P-206-W FAFNIR										
	228	1 OUTBOARD BEARING	P-7307-PW										
	229	1 BEARING LOCKNUT	STEEL										
	230	1 BEARING LOCKWASHER	STEEL										
	SS	1 BEARING SHIM	STEEL										
	232	1 BEARING COVER	CAST IRON										
	233	1 BEARING COVER GASKET	BUNA-N										
	GFC	1 FRONT COVER GASKET	VELLUMOID										
	235	1 OUTBOARD OIL SEAL	087-162-12										
	236	1 BEARING HOUSING BREATHER	STEEL										
	237	1 CONSTANT LEVEL OILER	PLASTIC STEEL										
	241	1 COUPLING KEY	STEEL										
	249	1 TRAP COVER GASKET	Sepco-6234 (Gylon, Teflon, etc., Optional)										
	250	1 TRAP GASKET	Sepco-6234 (Gylon, Teflon, etc., Optional)										
	251	1 SEPARATOR GASKET	Sepco-6234 (Gylon, Teflon, etc., Optional)										

* SEE ALLOY SELECTION CHART FOR OTHER AVAILABLE MATERIALS

o ONLY WHEN SPECIFIED

LaBour Self Priming Pump Group LHLA / LPLA

CUSTOMER:
CUST. ORDER:
LIQUID:
ITEM#
PUMP S/N:
CERTIFIED BY: TV

FASTENER TIGHTENING

FASTENER SIZE	TORQUE LB-FT
5/16 - 18	11
3/8 - 10	20
7/16 - 14	30
1/2 - 13	50
9/16 - 12	65
5/8 - 11	90
3/4 - 10	160
7/8 - 9	140
1 - 8	220
1 1/8 - 7	300
1 1/4 - 7	420
1 3/8 - 6	560
1 1/2 - 6	740

OILER INSTALLATION

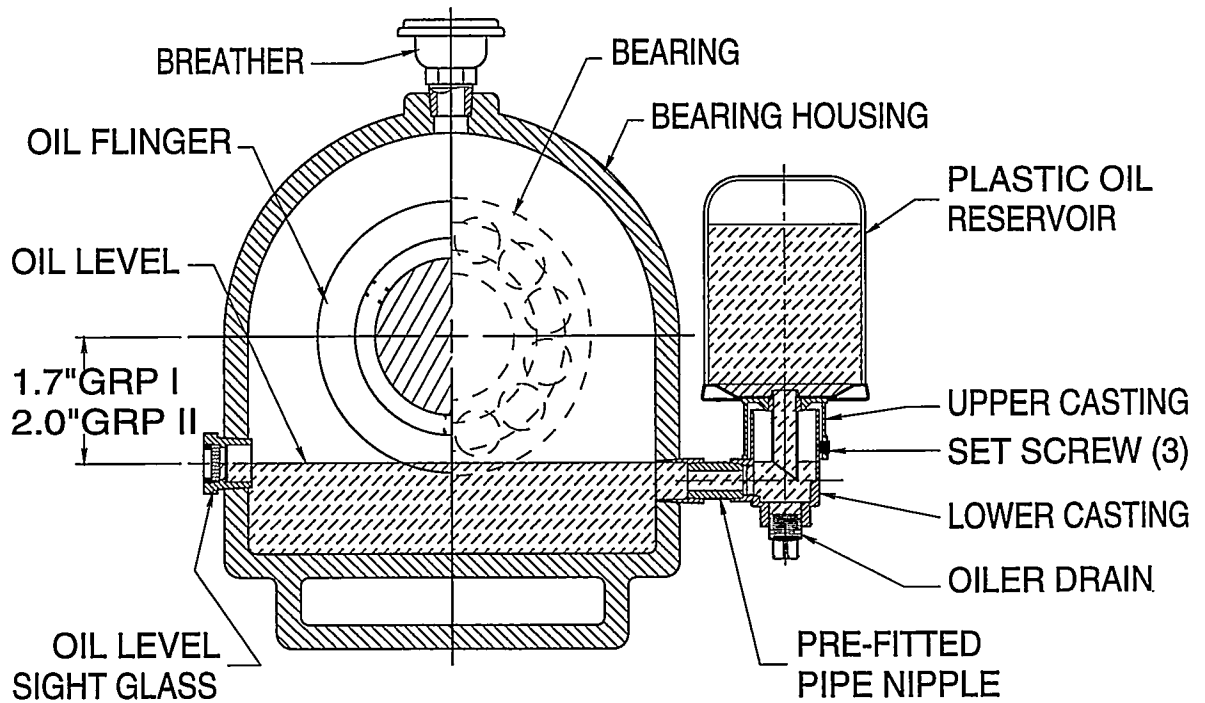

1 General

LaBour Pumps are shipped with the oil drained from the bearing housing and a plastic thread protector on the oiler mounting nipple. The oiler is packaged separately and is included in an accessory box fastened to pump shipping skid. The oiler manufacturers installation instructions are included with the oiler.

2 Oiler Installation

The bearing housing has been pre-drilled and tapped at the factory to the correct dimension and no further machining or adjusting is required.

Remove oiler from box, loosen (3) set screws holding upper casting to lower casting and remove upper casting with plastic reservoir intact.

Remove plastic thread protector from pipe nipple installed in bearing housing and seal threads with teflon tape or a suitable thread sealing compound.

Thread lower oiler casting onto bearing housing pipe nipple by hand.

Using an acceptable non-detergent oil, fill the bearing housing by pouring oil into the lower casting of the oiler until level is just visible in the lower casting for recommended oil see oil lubrication guide). Use the oiler reservoir to fill beyond this point to prevent over filling.

Tip reservoir so that bevelled stem is facing upward and fill with oil. Place thumb over reservoir spout, invert and slide reservoir and upper casting over lower casting until it seats as low as possible. The oil level is determined by the setting of the reservoir so it is important to make sure that the reservoir seats as low as possible. Several fillings of the oiler reservoir may be required before the final oil level is reached. When no more oil will run out of the reservoir bottle the oil level should be in the middle of the oil level sight glass.

Tighten the three set screws to secure upper casting to lower casting. From this point on only a periodical filling of the lubricator's reservoir is required.

!-NOTE-!

It is extremely important that the proper oil level is maintained. Too low an oil level will result in rapid bearing failure. Too high of an oil level will cause foaming and heating of the bearings. Degradation of the oil and premature bearing failure will occur.

The proper oil level range will be ± 0.050 " from the centerline of the oil level sight glass.

!-CAUTION-!
DO NOT OVER-TIGHTEN
Castings on oiler are zinc and over-tightening can result in thread damage and oil leakage.

Oil Leakage Trouble Shooting Guide

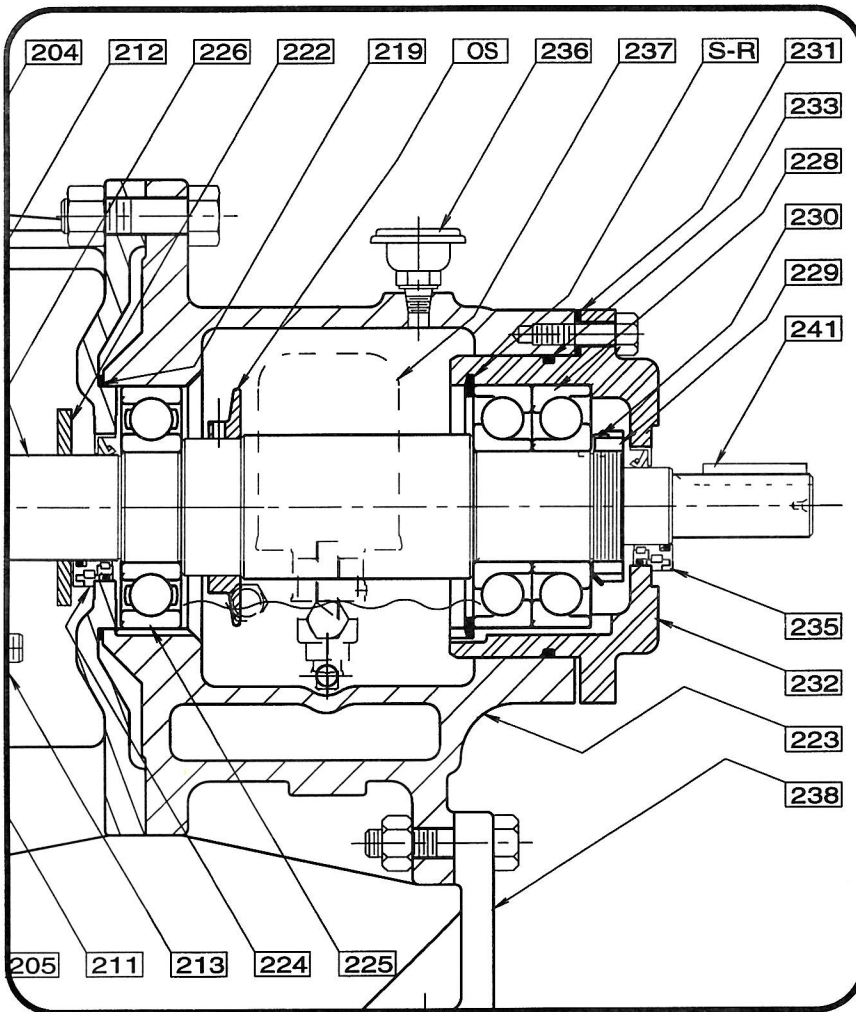

2 Rear Oil Seal (235)

Visually check oil seal (235) to determine if it is leaking. If no leak is found go to step 3. If leakage is found, determine the point of leakage. Refer below for leakage paths and the recommended remedy.

2.1 Leakage between oil seal (235) and shaft (226). Check shaft at point of lip seal contact for scratches, dents or burrs. If present, these can usually be removed by carefully polishing the shaft with 3M Scotch Pad #744A or equal. If the damage is too severe for this type of procedure, the shaft must be machined or replaced. If it is found that the shaft is in good condition, check the oil seal for a damaged lip or missing garter spring. If the oil seal is damaged in any way it must be replaced.

2.2 Leakage between oil seal (235) and bearing housing (223) bore. The oil seal will have to be replaced. When installing new oil seal, coat outside diameter of oil seal only with loctite #2 or #6 to be certain that a good seal is obtained.

Introduction

All LaBour bearing housings undergo rigorous quality control testing at the factory before shipment, and under normal operating conditions no problem should be encountered. Regardless of the condition of the pump when it leaves the factory, the possibility of damage during shipping, handling or storage is real and the following is intended as a guide in determining the cause of any oil leakage that might be encountered.

1 O-Ring, Bearing Cartridge (233)

Any oil leakage between the Bearing Housing (223) and the flange of the Bearing Cartridge (232) indicates that the O-Ring (233) has been damaged and must be replaced.

3 Front Oil Seal (224)

The procedure for the front oil seal is the same as for the rear oil seal in step #2. The location of the front oil seal is in the adapter for group "II" or "III" pumps and in a separate front cover (FC) on the group "I" pumps.

4 Adapter Gasket (219)

Check for leakage at joint between adapter (218) and bearing housing (223), if none present, go to step #5. If leakage is present the bearing housing assembly will have to be dismantled and adapter (218) removed to gain access to gasket (219). The gasket consists of a stationary "O" ring. Remove gasket AND check for burrs or scratches on sealing faces of bearing housing & adapter. Remove any defects by polishing with 3M Scotch Pad #744A or equal, remember any scratch will

Recommended Bearing Lubricants

The following lubricants are recommended oils for LaBour Pumps.

MANUFACTURER	AMBIENT TEMPERATURE	OIL TYPE
Amoco Oil (1-800/652-6626)	30 to 100 °F -10 to 70 °F	Amoco Industrial Oil #68 Amoco Industrial Oil #46
Atlantic Richfield (1-800/447-4572)	30 to 100 °F -10 to 70 °F	Duro #68 Duro #46
Chevron (1-800/582-3835)	30 to 100 °F -10 to 70 °F	Turbine Oil GST #68 Turbine Oil GST #32
Conoco (1-800/255-9556)	30 to 100 °F 0 to 70 °F	Dectol R&O Oil #68 Dectol R&O Oil #46
Exxon Co. (1-800/443-9966)	30 to 100 °F 0 to 70 °F	Teresstic 68 Teresstic 46
Mobil Oil Co. (1-800/662-4525)	30 to 100 °F	DTE Heavy- Medium
Phillips Petroleum Co. (1-918/661-6600)	30 to 100 °F -10 to 70 °F	Magnus 68 Magnus 32
Texaco Inc. (1-800/782-7852)	30 to 100 °F -10 to 70 °F	Regal R&O 68 Regal R&O 32

NOTE:

It is suggested that additional or replacement oil be added after 2000 hours or at 90 days interval, whichever comes first.

The oil in the bearing housing should be changed at least once each year. This should be done when the annual overhaul is made.

For pumps with GREASE lubricated bearings, contact LaBour or their local Representative for lubrication instructions.

WOODS COUPLING ALIGNMENT

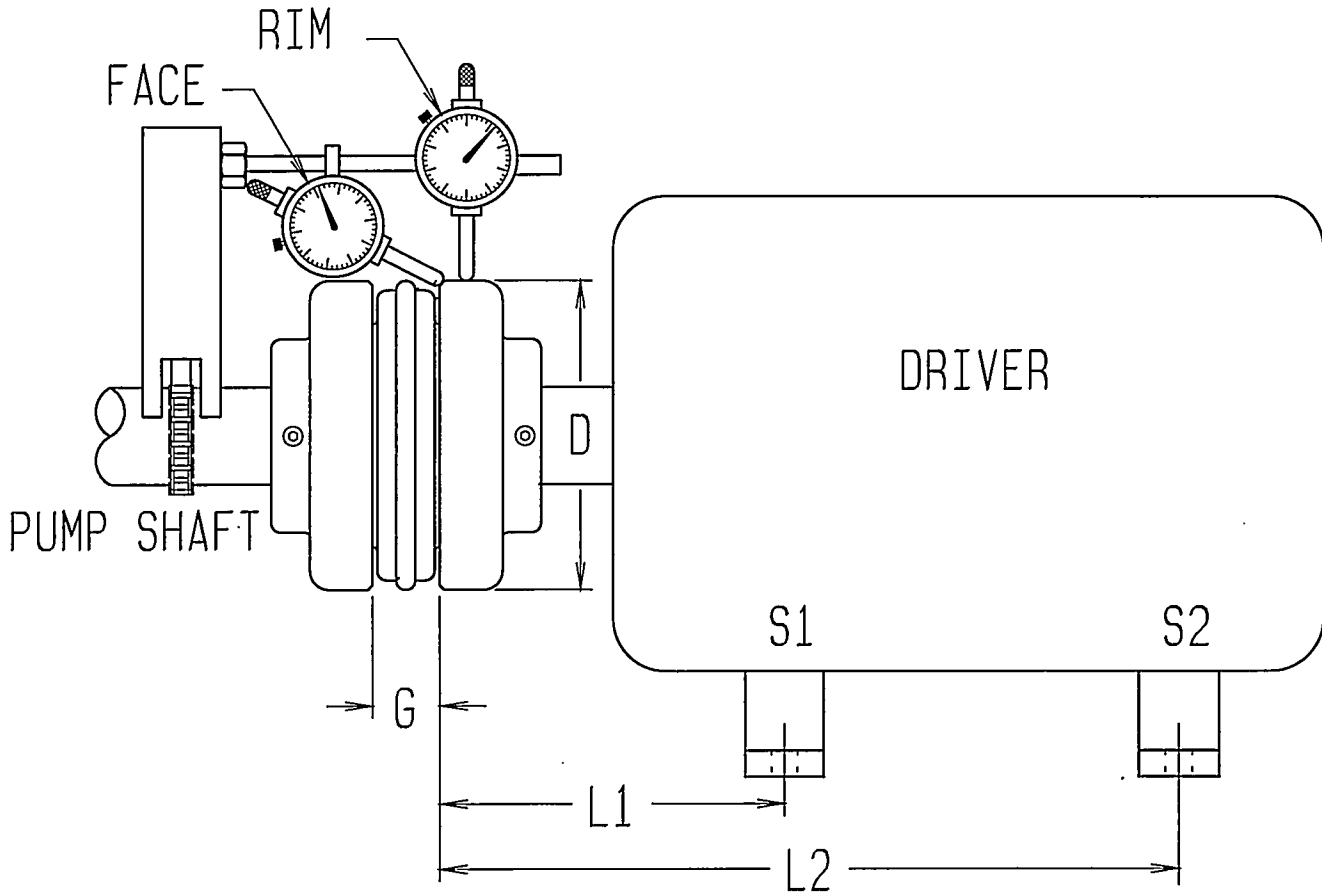

SLEEVE SIZE	RPM MAX	RIM MAX T.I.R.	FACE MAX T.I.R.	G +/- 0.06	D DIA
3	9200	0.005	0.010	0.375	2.062
4	7600	0.005	0.012	0.625	2.460
5	7600	0.007	0.014	0.875	3.250
6	6000	0.007	0.016	0.750	4.000
7	5250	0.010	0.020	1.000	4.625
8	4500	0.010	0.025	1.125	5.450
9	3750	0.012	0.028	1.438	6.350
10	3600	0.012	0.032	1.625	7.500
11	3600	0.016	0.037	1.875	8.625
12	2800	0.016	0.042	2.313	10.000
13	2400	0.020	0.050	2.688	11.750
14	2200	0.022	0.060	3.250	13.875
16	1500	0.031	0.070	4.750	18.875

WOODS COUPLING ALIGNMENT

ALIGNMENT PROCEDURE, RIM AND FACE METHOD

1. Reference the previous page for the maximum rim and face misalignment allowed for the size of coupling sleeve you are using. Be sure that the distance between the coupling faces are within the "G" dimension listed in the table.
2. Obtain the coupling hub diameter "D" from the table and enter below.
3. Measure L1 & L2 as shown on the previous page and enter these values below.
4. Mount the indicators as shown.
5. Check for and correct for "soft foot" as follows:
 - A. Loosen and tighten each driver foot fastener, one at a time, noting any changes on the rim indicator while positioned at 12 o'clock.
 - B. Add shims under any driver foot with a "soft foot" condition, until no more than 0.002" movement is indicated when the foot fastener is tightened or loosened.
6. Zero the indicators at the twelve o'clock position. Rotate both shafts to the six o'clock position. Record the rim and face readings in the space provided below. Note the direction of the indicator movement (+ / -).

D=_____, **L1=_____**, **L2=_____**, **TIR RIM =_____**, **TIR FACE=_____**

7. Enter the data in the following equations and calculate:

$$S1 = (L1/D) \times [(+/-) \text{ TIR FACE}] + 1/2 \times [(+/-) \text{ TIR RIM}] = \underline{\hspace{2cm}}$$

$$S1 = (\underline{\hspace{1cm}}) \times [\underline{\hspace{1cm}}] + 1/2 \times [\underline{\hspace{1cm}}] = \underline{\hspace{2cm}}$$

$$S2 = (L2/D) \times [(+/-) \text{ TIR FACE}] + 1/2 \times [(+/-) \text{ TIR RIM}] = \underline{\hspace{2cm}}$$

$$S2 = (\underline{\hspace{1cm}}) \times [\underline{\hspace{1cm}}] + 1/2 \times [\underline{\hspace{1cm}}] = \underline{\hspace{2cm}}$$

8. If S1 is positive, add that amount of shims below each of the front driver feet (remove shims if negative). If S2 is positive, add that amount of shims below each of the rear driver feet (remove shims if negative).
9. Tighten the driver foot fasteners and repeat steps #6, #7 & #8 until good up and down alignment is obtained.
10. Use the rim and face indicator readings at three and nine o'clock positions to adjust the side to side alignment. Tighten the driver foot fasteners.
11. Recheck the rim and face alignment at all positions to confirm that the alignment is within the specifications given on the previous page.

NOTE:

- 1. Always align the driver to the pump.**
- 2. During alignment, the pump and driver shafts should be rotated together to eliminate any effect of coupling machining irregularities.**

LHLA NOZZLE LOADS

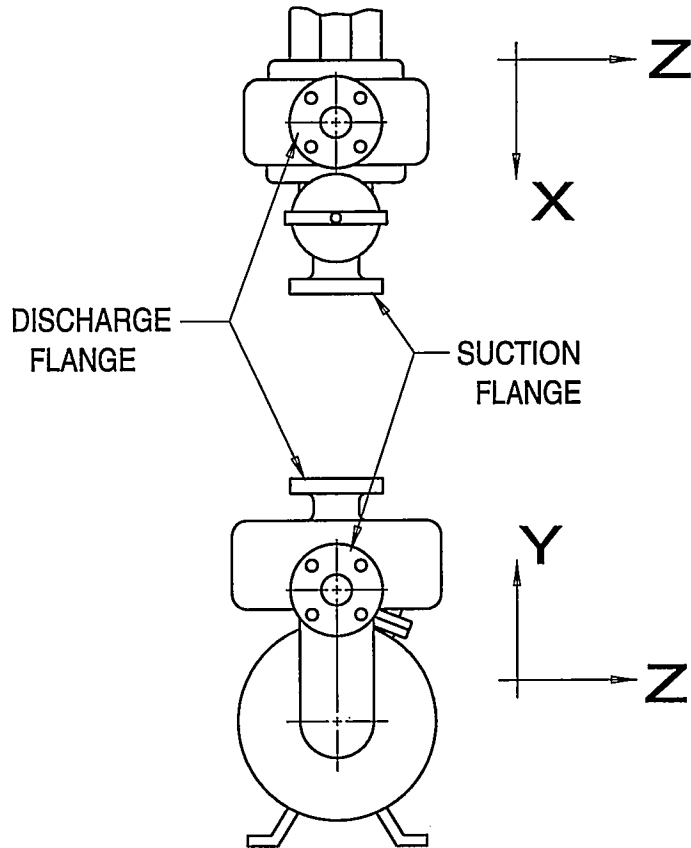

SIZE	SUCTION FLANGE						DISCHARGE FLANGE					
	FX	FY	FZ	MX	MY	MZ	FX	FY	FZ	MX	MY	MZ
10W	200	130	160	340	260	170	100	65	80	170	130	85
12W	200	130	160	340	260	170	100	65	80	170	130	85

NOTE:

1. FX, FY, FZ = MAXIMUM FORCE IN POUNDS.
2. MX, MY, MZ = MAXIMUM MOMENT IN FOOT-POUNDS FOR EACH NOZZLE.
3. WHEN SUMMING MOMENTS, THE MAXIMUM FORCES, GIVEN ABOVE, TIMES THEIR LEVER ARM, MAY BE ADDED TO THE MAXIMUM MOMENTS LISTED.
4. THE LOADS LISTED ABOVE CAN ONLY BE ACHIEVED WHEN THE PUMP IS FREE OF "SOFT FOOT" AND THE HOLD DOWN BOLTS ARE TORQUED TO AT LEAST A GRADE 2 VALUE.

LPLA NOZZLE LOADS

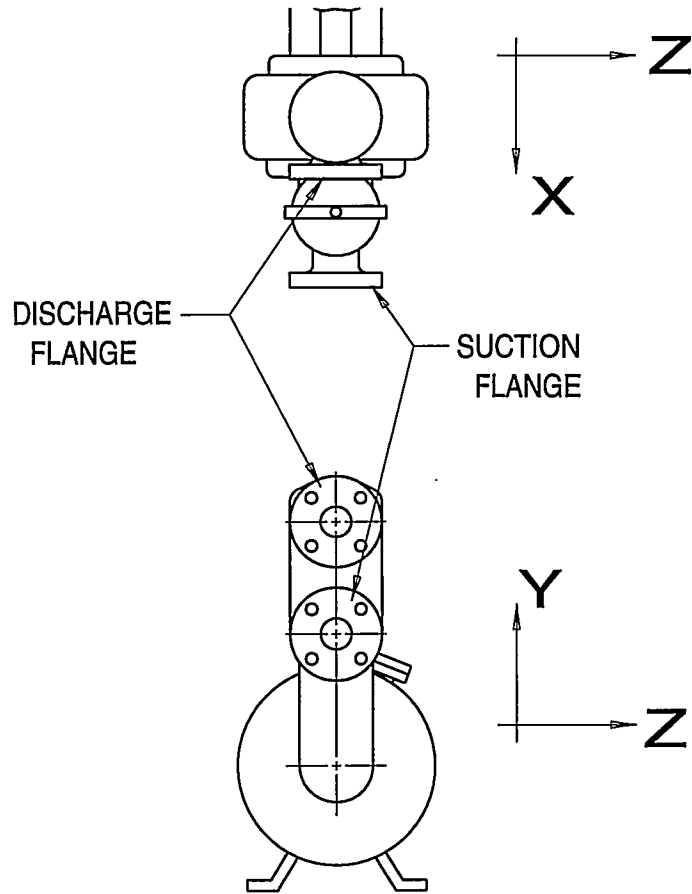

SIZE	SUCTION FLANGE						DISCHARGE FLANGE					
	FX	FY	FZ	MX	MY	MZ	FX	FY	FZ	MX	MY	MZ
15W	200	130	80	70	260	170	100	60	80	170	130	80
20XW	300	200	100	100	530	350	150	100	120	350	260	170
23XW	300	200	100	100	530	350	150	100	120	350	260	170

NOTE:

1. FX, FY, FZ = MAXIMUM FORCE IN POUNDS.
2. MX, MY, MZ = MAXIMUM MOMENT IN FOOT-POUNDS FOR EACH NOZZLE.
3. WHEN SUMMING MOMENTS, THE MAXIMUM FORCES, GIVEN ABOVE, TIMES THEIR LEVER ARM, MAY BE ADDED TO THE MAXIMUM MOMENTS LISTED.
4. THE LOADS LISTED ABOVE CAN ONLY BE ACHIEVED WHEN THE PUMP IS FREE OF "SOFT FOOT" AND THE HOLD DOWN BOLTS ARE TORQUED TO AT LEAST A GRADE 2 VALUE.

MAX-LIFE™ SEAL CHAMBER

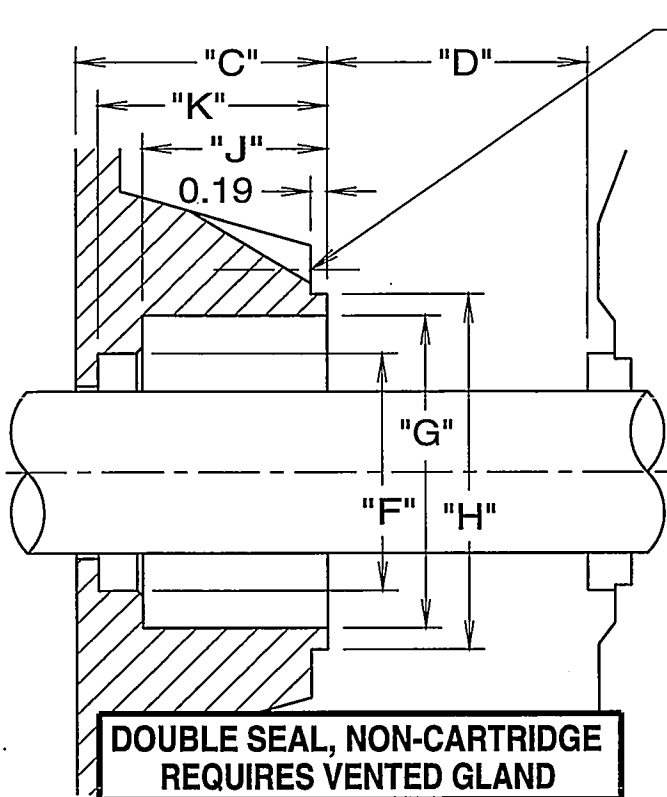
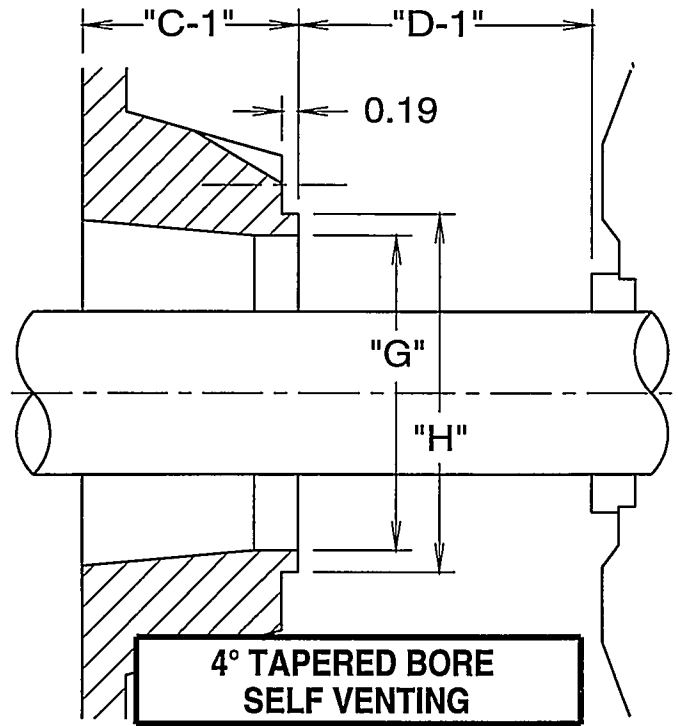
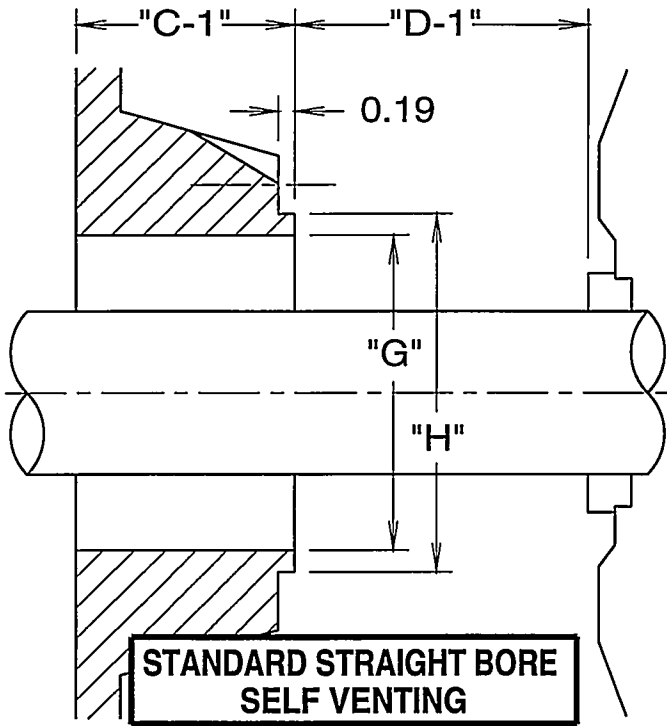

(4) "A" STUDS EQ SPACED
ON "B" BOLT CIRCLE
STRADDLING CENTERLINES

DIM	TOL	SHAFT DIA +/- 0.001		
		Ø1.125	Ø1.375	Ø1.875
"A"	NOMINAL	3/8-16	3/8-16	1/2-13
"B"	+/- 0.03	Ø3.75	Ø4.50	Ø5.00
"C"	+/- 0.02	2.44	2.44	2.87
"C-1"	+/- 0.02	2.00	2.00	2.50
"D"	+/- 0.03	1.75	1.75	2.93
"D-1"	+/- 0.03	2.19	2.13	3.31
"F"	+0.002	Ø1.750	Ø2.000	Ø2.625
"G"	+0.002	Ø2.625	Ø2.875	Ø3.625
"H"	-0.002	Ø3.125	Ø3.597	Ø4.125
"J"	+/- 0.02	1.75	1.72	2.13
"K"	+/- 0.02	2.19	2.19	2.63

VIBRATION MONITORING

1 VIBRATION & PREDICTIVE MAINTENANCE

Vibration Monitoring should be part of a Structured Predictive Failure Analysis Program. Early detection of pump problems is desirable, when damage is minor, so equipment is analyzed on-line for diagnosis. Mechanical problems are determined before catastrophic failure; therefore, maintenance can be scheduled at a time that is convenient. The result of a good Predictive Maintenance Program is reduced downtime, reduced maintenance costs, prevention of secondary damage and improved plant safety.

A Predictive Maintenance Program is specifically tailored to the user's needs; as a result, programs and monitoring equipment vary from user to user. Therefore, we can only offer simple guidelines for vibration monitoring. Ultimately, the success of the program relies on the expertise of the user.

2 MONITORING SCHEDULES

Pumps should be monitored in accordance with a prescribed schedule where vibration levels are recorded on an equipment data sheet to establishing a history of the unit's condition. A trend of increasing vibration level is a sign of developing mechanical problems. These increases are compared to a baseline reading and maintenance is schedule at a predetermined vibration increase. A graph showing vibration trend VS monitoring date is a very useful analysis tool.

The baseline vibration level is the vibration of the unit while it is operating in good condition, without cavitation, with good coupling alignment, without undo pipe strains, and with straight suction piping to the casing for uniform flow. If previous vibration history is unavailable, a baseline reading can be determined from a similar unit operating in good condition, or the factory can be consulted for a baseline value taken when the pump was tested before shipment.

Monitoring schedules are predetermined by the program administrator and will vary by application and useful failure detection period. This period is based on the time between confirmation of a machine problem and catastrophic failure.

Pumps that are in a very critical or hazardous service should be considered for a continuous monitoring system that will shut down or alarm at the predetermined vibration level increase.

3 SCHEDULED MAINTENANCE

Maintenance should be scheduled at a predetermined vibration level increase above the baseline

value. This level is determined by the user and will vary, depending on the application.

As a general rule, maintenance should be scheduled when:

1. Vibration exceeds twice the baseline value.
2. Vibration level exceeds 0.20 in/sec.

4 MEASURING PROCEDURE

1. Connect the pickup (accelerometer). The pickup should be placed on a rigid part of the pump where it can be securely held, typically in a horizontal/radial position on the bearing housing. The pickup must be connected at the same location each time the pump is monitored. This location should be illustrated on the data sheet and/or physically marked on the pump.

2. Check the operating conditions. The pump vibration will vary at different points along the pump performance curve, so the pump head and capacity should be at the design or baseline condition each time the unit is monitored.

3. Take a reading. Turn the vibration analyzer to the Velocity (in/sec) setting and set to an appropriate scale (the lowest setting that will read full amplitude). Make a spectrum plot and mark the maximum velocity on the pump data sheet.

4. Check results. Compare vibration readings to the baseline reading and previous readings. It is useful to have a trend chart that shows changes in vibration level with respect to monitoring dates.

VIBRATION LIMITS

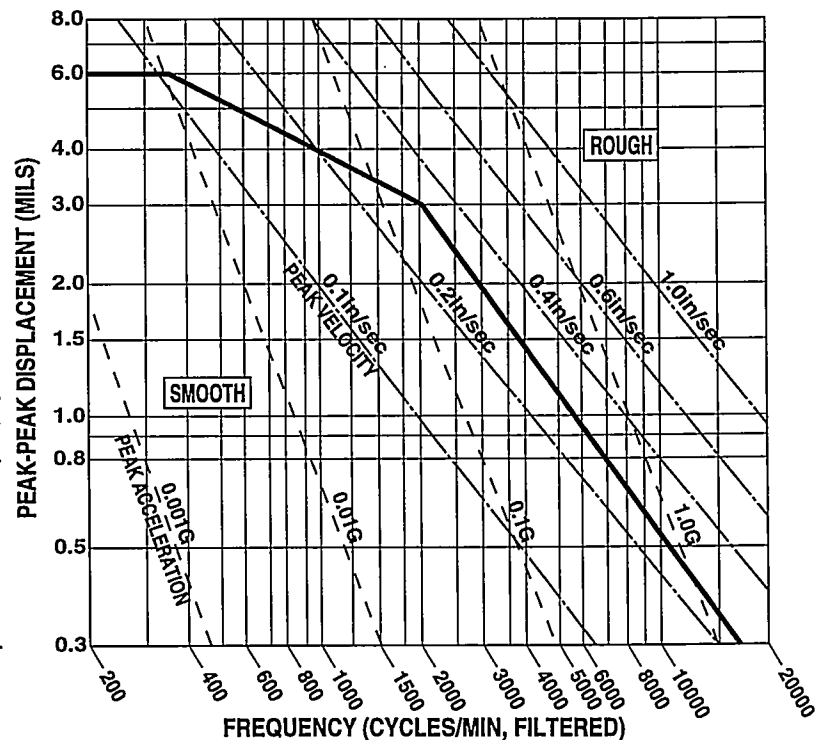

ANSI B16.5 & B16.42 FLANGES

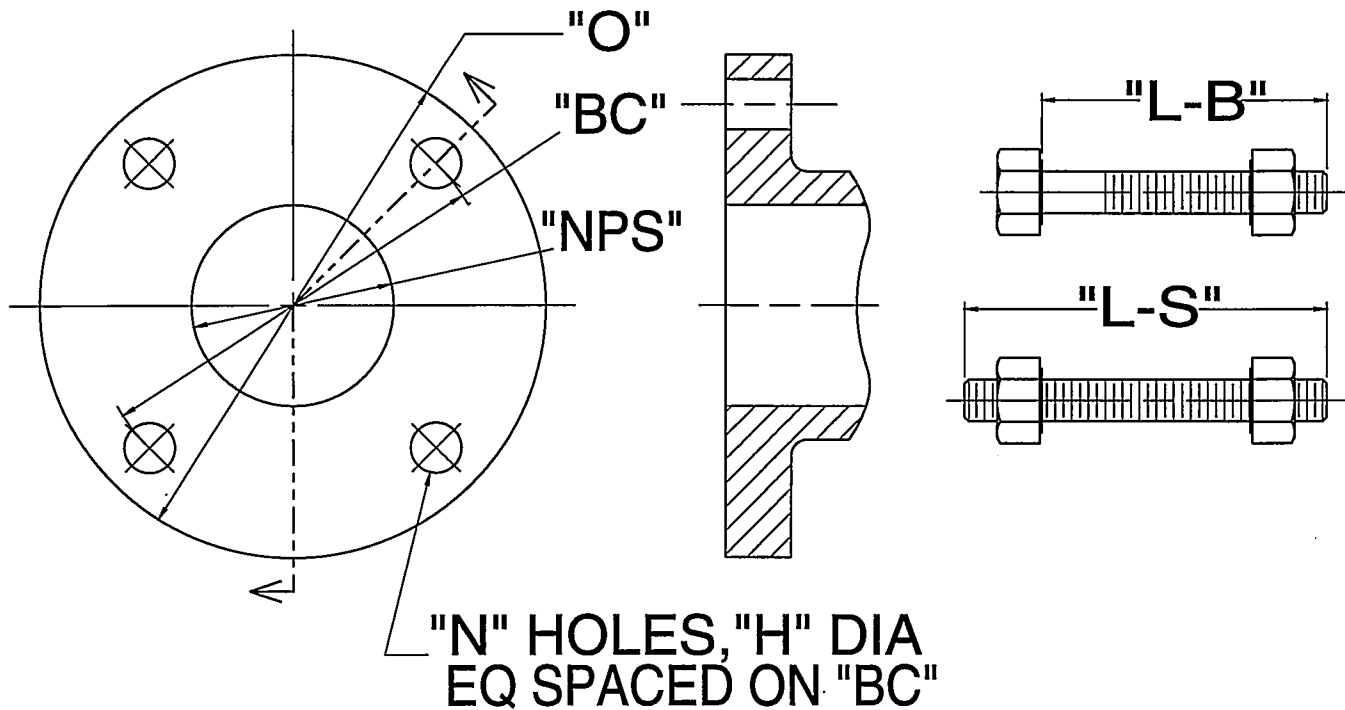

NOM. PIPE SIZE	150 - LB FLANGE							300 - LB FLANGE						
	"H" DRILL THRU	"N" # OF HOLES	"O" DIA REF	"BC" DIA +/- .02"	BOLT DIA	"L-B"	"L-S"	"H" DRILL THRU	"N" # OF HOLES	"O" DIA REF	"BC" DIA +/- .02"	BOLT DIA	"L-B"	"L-S"
0.50	0.62	4	3.50	2.38	0.500	2.00	2.50	0.62	4	3.75	2.62	0.500	2.00	2.50
0.75	0.62	4	3.88	2.75	0.500	2.25	2.50	0.75	4	4.62	3.25	0.625	2.50	2.75
1.0	0.62	4	4.25	3.12	0.500	2.25	2.75	0.75	4	4.88	3.50	0.625	2.50	3.00
1.25	0.62	4	4.62	3.50	0.500	2.50	2.75	0.75	4	5.25	3.88	0.625	2.75	3.00
1.5	0.62	4	5.00	3.88	0.500	2.50	3.00	0.88	4	6.12	4.50	0.750	3.00	3.50
2.0	0.75	4	6.00	4.75	0.625	2.75	3.25	0.75	8	6.50	5.00	0.625	3.00	3.25
2.5	0.75	4	7.00	5.50	0.625	3.00	3.50	0.88	8	7.50	5.88	0.750	3.25	3.75
3.0	0.75	4	7.50	6.00	0.625	3.25	3.75	0.88	8	8.25	6.62	0.750	3.50	4.00
3.5	0.75	8	8.50	7.00	0.625	3.25	3.75	0.88	8	9.00	7.25	0.750	3.75	4.25
4.0	0.75	8	9.00	7.50	0.625	3.25	3.75	0.88	8	10.00	7.88	0.750	3.75	4.25
5.0	0.88	8	10.00	8.50	0.750	3.25	4.00	0.88	8	11.00	9.25	0.750	4.00	4.50
6.0	0.88	8	11.00	9.50	0.750	3.50	4.00	0.88	12	12.50	10.62	0.750	4.25	4.75
8.0	0.88	8	13.50	11.75	0.750	3.50	4.25	1.00	12	15.00	13.00	0.875	4.75	5.25
10.0	1.00	12	16.00	14.25	0.875	4.00	4.75	1.12	16	17.50	15.25	1.000	5.25	6.00
12.0	1.00	12	19.00	17.00	0.875	4.25	4.75	1.25	16	20.50	17.75	1.125	5.75	6.50
14.0	1.12	12	21.00	18.75	1.000	4.50	5.25	1.25	20	23.00	20.25	1.125	6.00	6.75
16.0	1.12	16	23.50	21.25	1.000	4.75	5.50	1.38	20	25.50	22.50	1.250	6.50	7.25
18.0	1.25	16	25.00	22.75	1.125	5.00	6.00	1.38	24	28.00	24.75	1.250	6.75	7.50
20.0	1.25	20	27.50	25.00	1.125	5.50	6.25	1.38	24	30.50	27.00	1.250	7.00	8.00
24.0	1.38	20	32.00	29.50	1.250	6.00	7.00	1.62	24	36.00	32.00	1.500	7.75	9.00

T D H		 LaBour PROCESS PUMPS ELKHART, IN. 46515	MODEL <u>10W</u>	TYPE <u>LPL</u>	IMPELLER NO. <u>10W8SD-BP</u>
M	FT		SIZE <u>2X2-6.88</u> in <u>25X25-175</u> mm	SIZE <u>25X25-175</u> mm	EYE AREA <u> </u> in ² <u> </u> mm ²
			SPEED <u>1750</u> rpm	<u> </u> max. sphere	CURVE NO. <u>10W17</u>

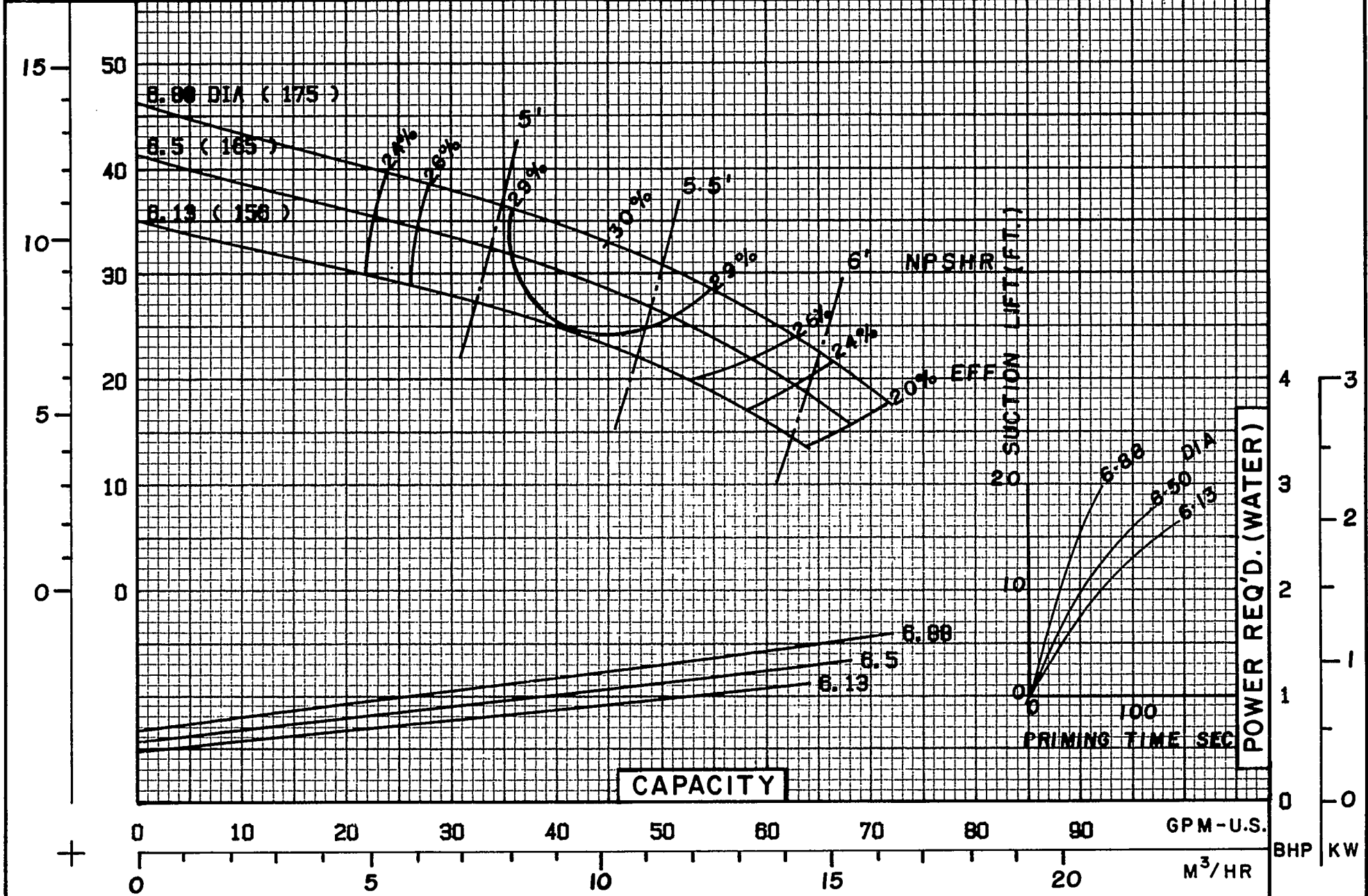

022585

CURVE NO. 10W17

T D H	LaBour PROCESS PUMPS ELKHART, IN. 46515		MODEL <u>10W</u>	TYPE <u>LPL</u>	IMPELLER NO. <u>10W8SD-BP</u>
M FT			SIZE <u>2X2-6.88</u> in <u>25X25-175</u> mm	SIZE <u>25X25-175</u> mm	EYE AREA _____ in ² _____ mm ²
			SPEED <u>3500</u> rpm	_____ max. sphere	CURVE NO. <u>10W35</u>

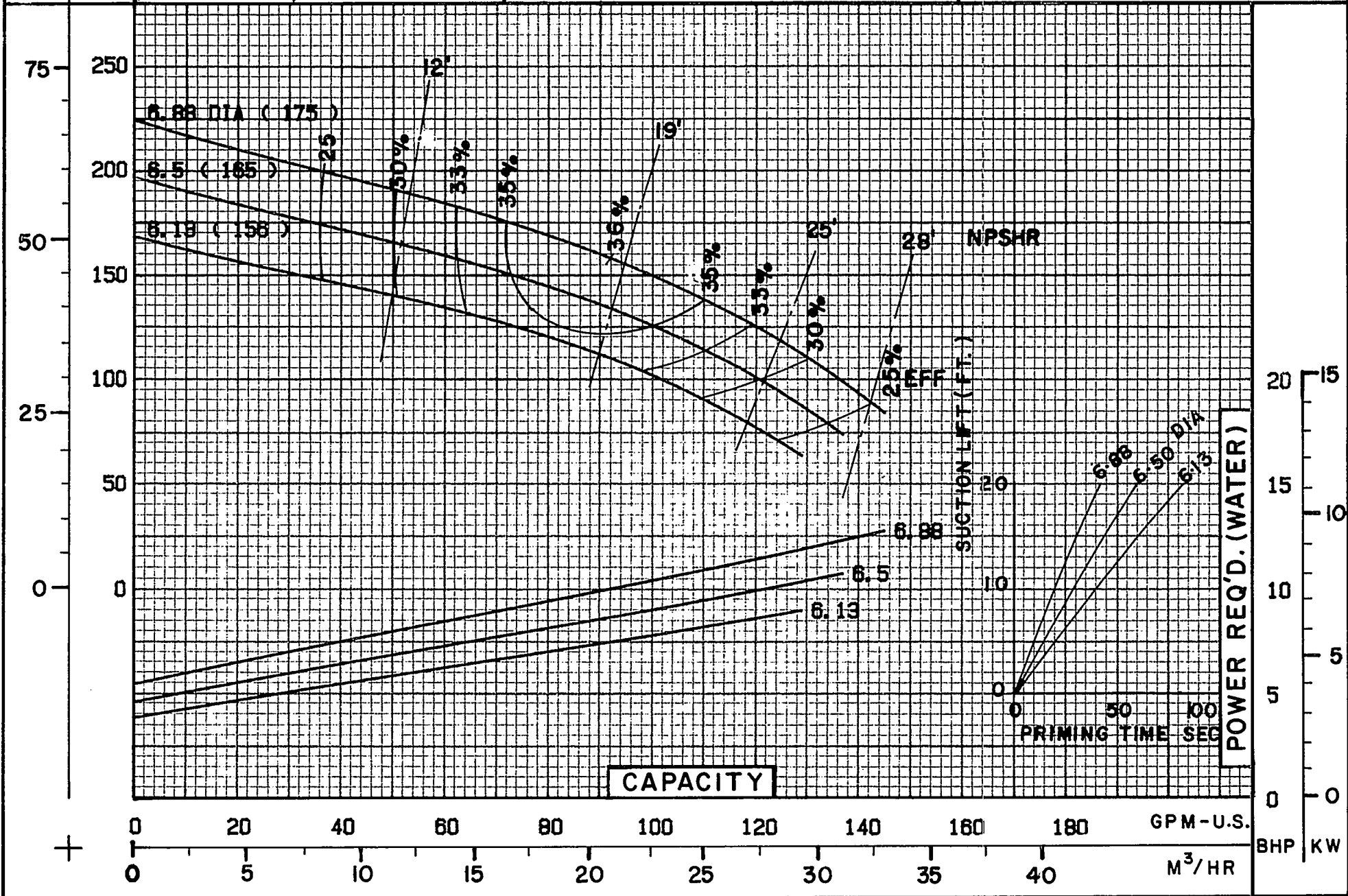

0225 85

CURVE NO. 10W 35

T D H	LaBour PROCESS PUMPS ELKHART, IN. 46515		MODEL <u>12W</u>	TYPE <u>LHL</u>	IMPELLER NO. <u>12W8SD-BP</u>
M FT			SIZE <u>2X2-8.0</u> in <u>25X25-203</u> mm	SIZE <u>25X25-203</u> mm	SIZE <u>25X25-203</u> mm
			SPEED <u>1750</u> rpm	max. sphere	CURVE NO. <u>12W17</u>

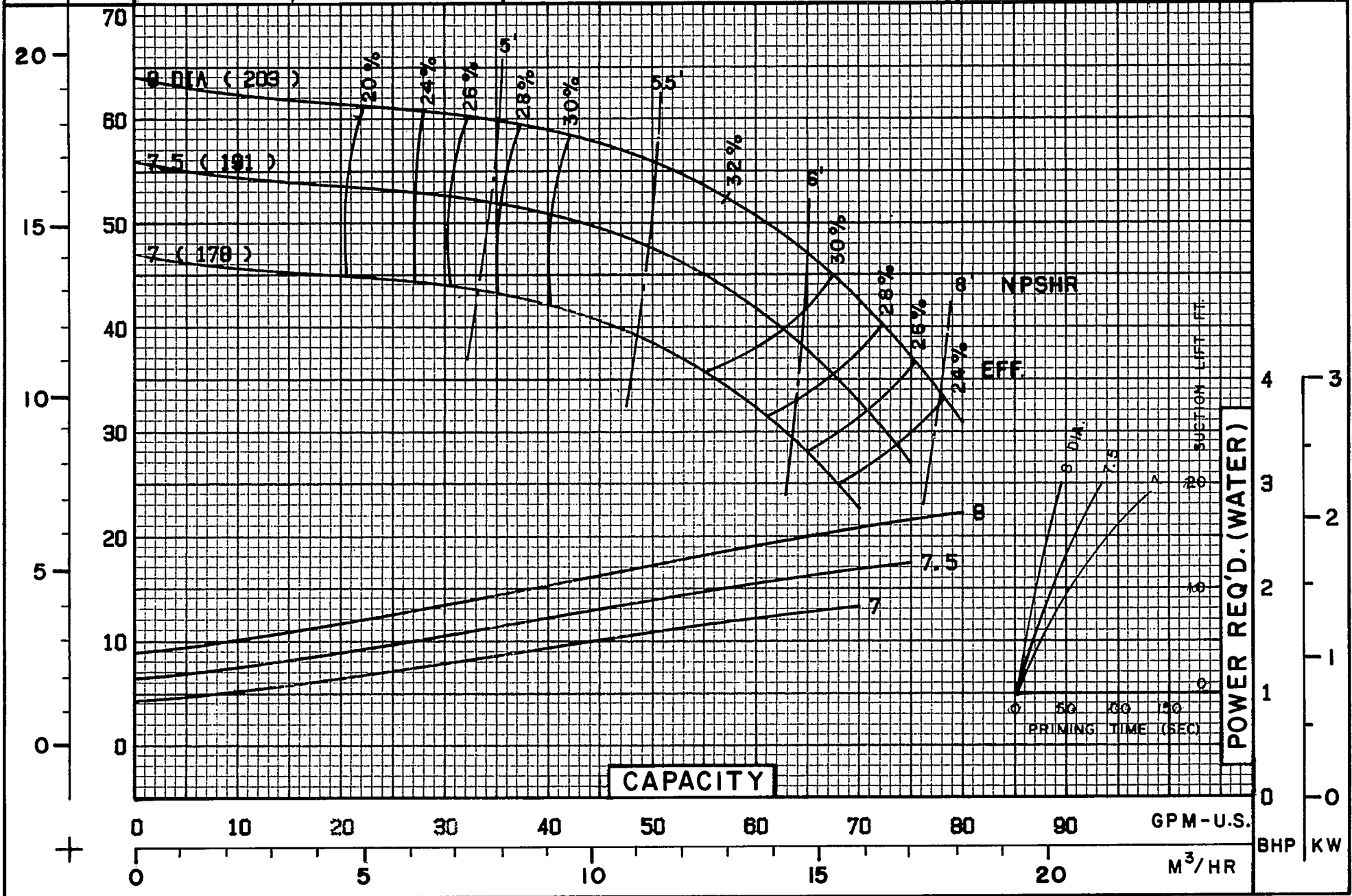

T D H	LaBour PROCESS PUMPS ELKHART, IN. 46515		MODEL <u>12W</u>	TYPE <u>LHL</u>	IMPELLER NO. <u>12W8SD-BP</u>
M FT			SIZE <u>2X2-8.0</u> in <u>25X25-203</u> mm	SIZE <u>25X25-203</u> mm	SIZE <u>25X25-203</u> mm
			SPEED <u>3500</u> rpm	max. sphere	CURVE NO. <u>12W-35</u>

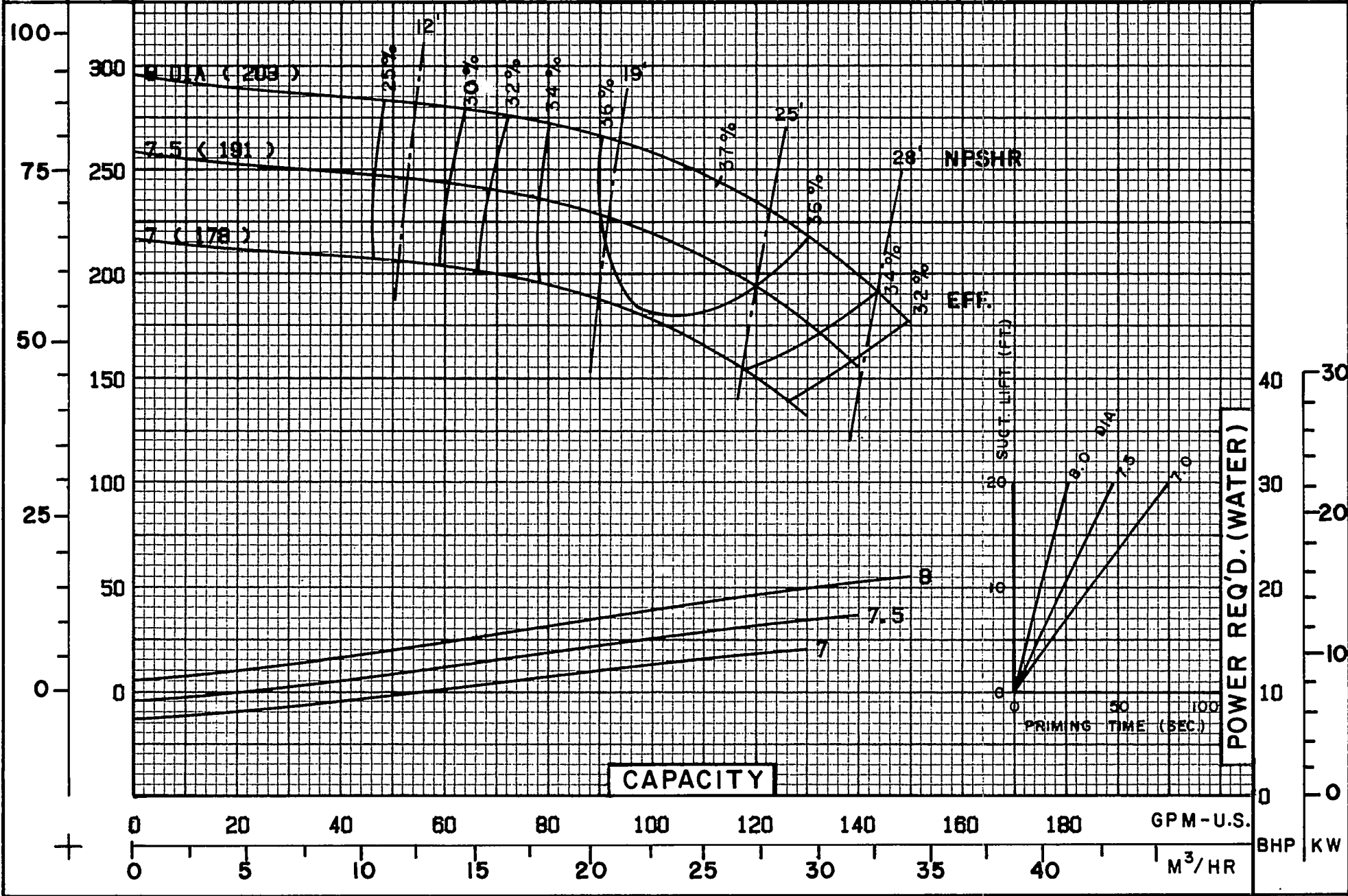

021985

CURVE NO. 12W-35

T D H

M FT

LaBour
 PROCESS PUMPS
 ELKHART, IN. 46515



MODEL 15W TYPE LPL
 SIZE 2.5X2.5-8.38 in 64X64-213 mm
 SPEED 1150 rpm max.sphere

IMPELLER NO. 15W-8SDBP
 EYE AREA in² mm²
 CURVE NO. 15W11-A

15 50

10 30

5 20

0 10

0 0

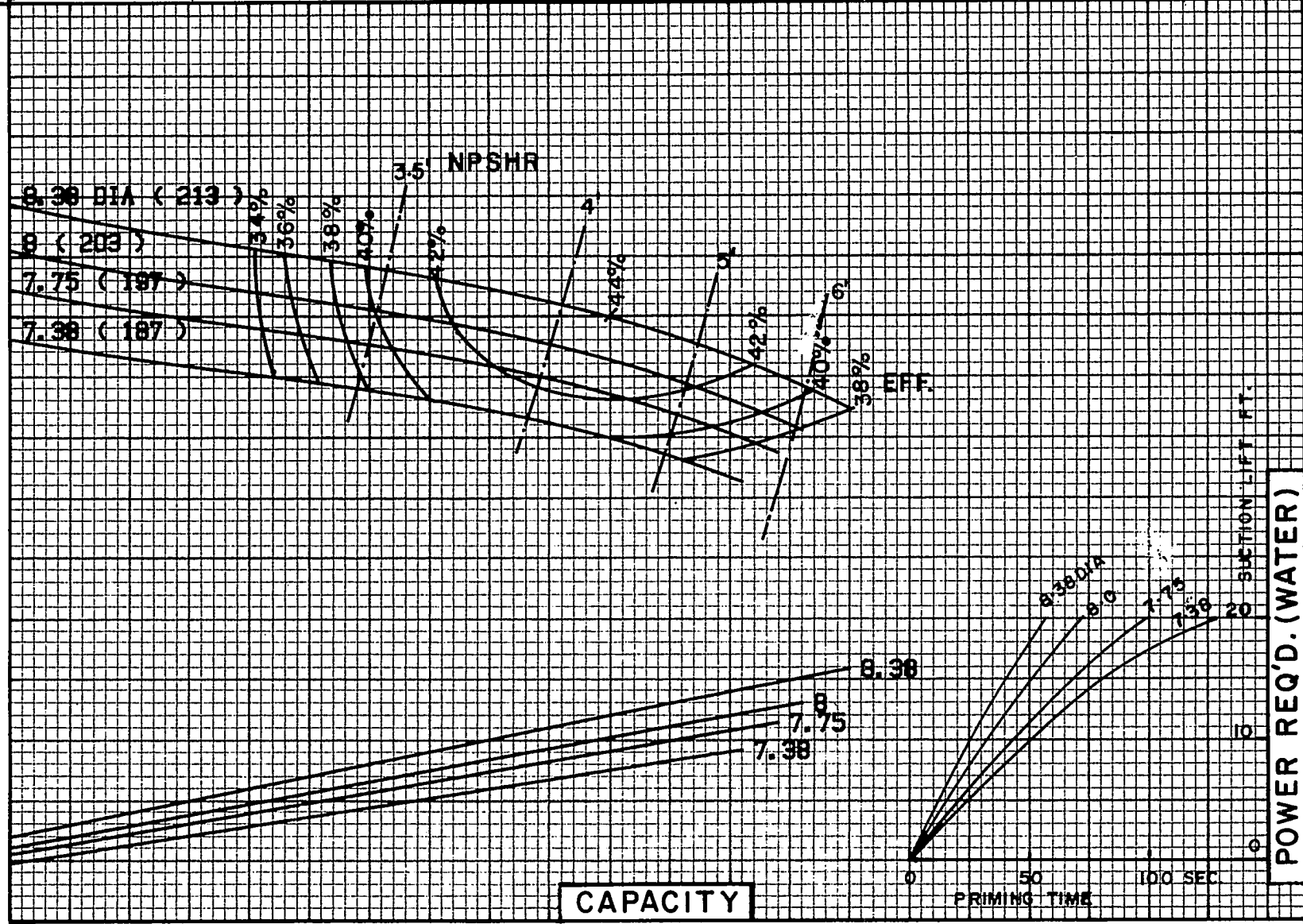

CAPACITY

PRIMING TIME

SUCTION LIFT FT.

POWER REQ'D. (WATER)

0 20 40 60 80 100 120 140 160 180 GPM-U.S.
 0 5 10 15 20 25 30 35 M³/HR

3
2
1
0
3
2
1
0
BHP KW

T D H

M FT



MODEL 15W TYPE LPL
 SIZE 2.5X2.5-8.38 in 64X64-213 mm
 SPEED 1750 rpm max.sphere

IMPELLER NO. 15W-8SD8P
 EYE AREA _____ in² _____ mm²
 CURVE NO. 15W17-A

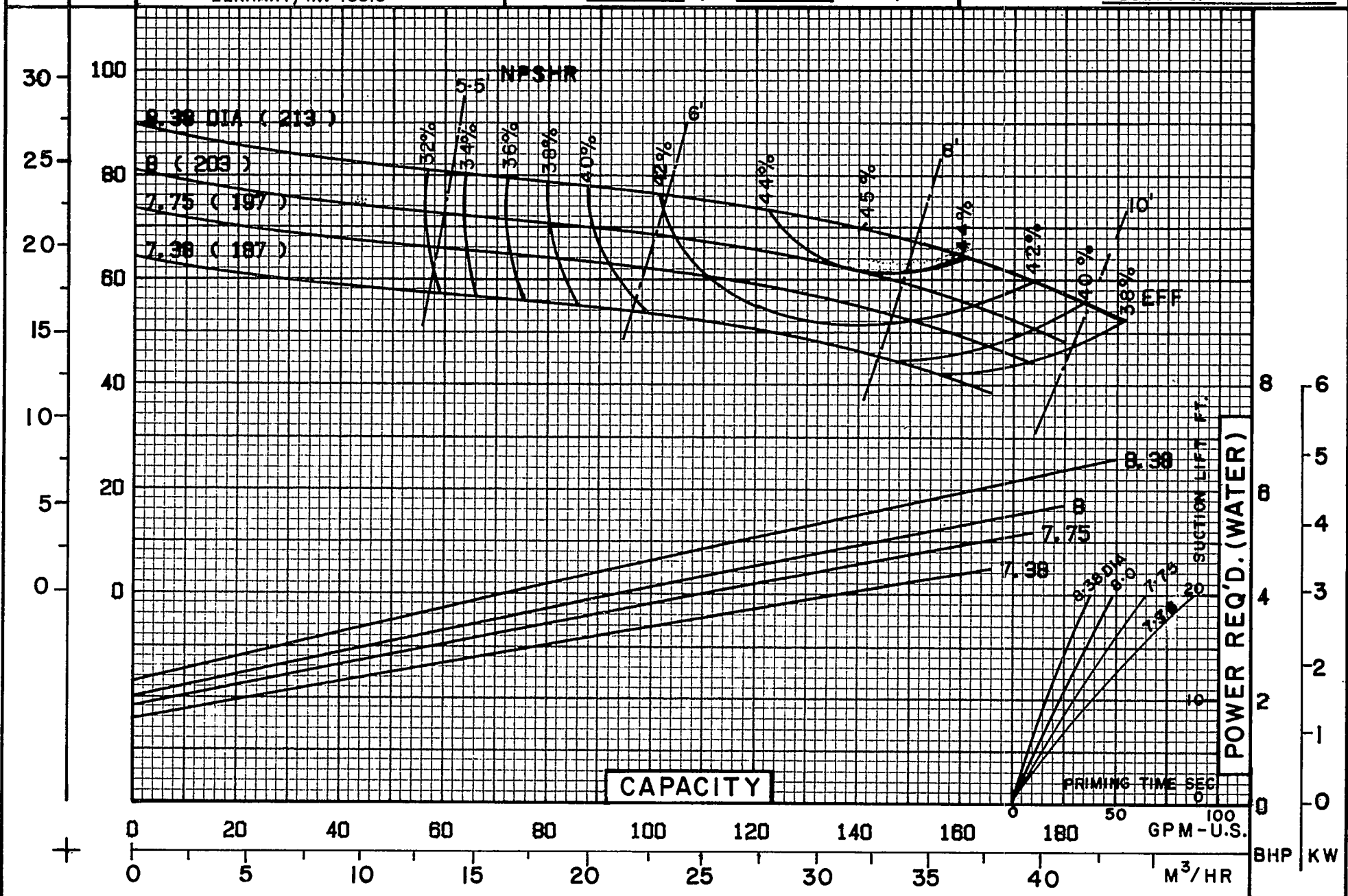

T D H

LaBour
PROCESS PUMPS
ELKHART, IN. 46515

MODEL 20XW TYPE LPL
SIZE 3X3-9.38 in 76X76-238 mm
SPEED 1150 rpm max.sphere

IMPELLER NO. 20XW8SD-BP
EYE AREA in² mm²
CURVE NO. 20XW-12

M FT

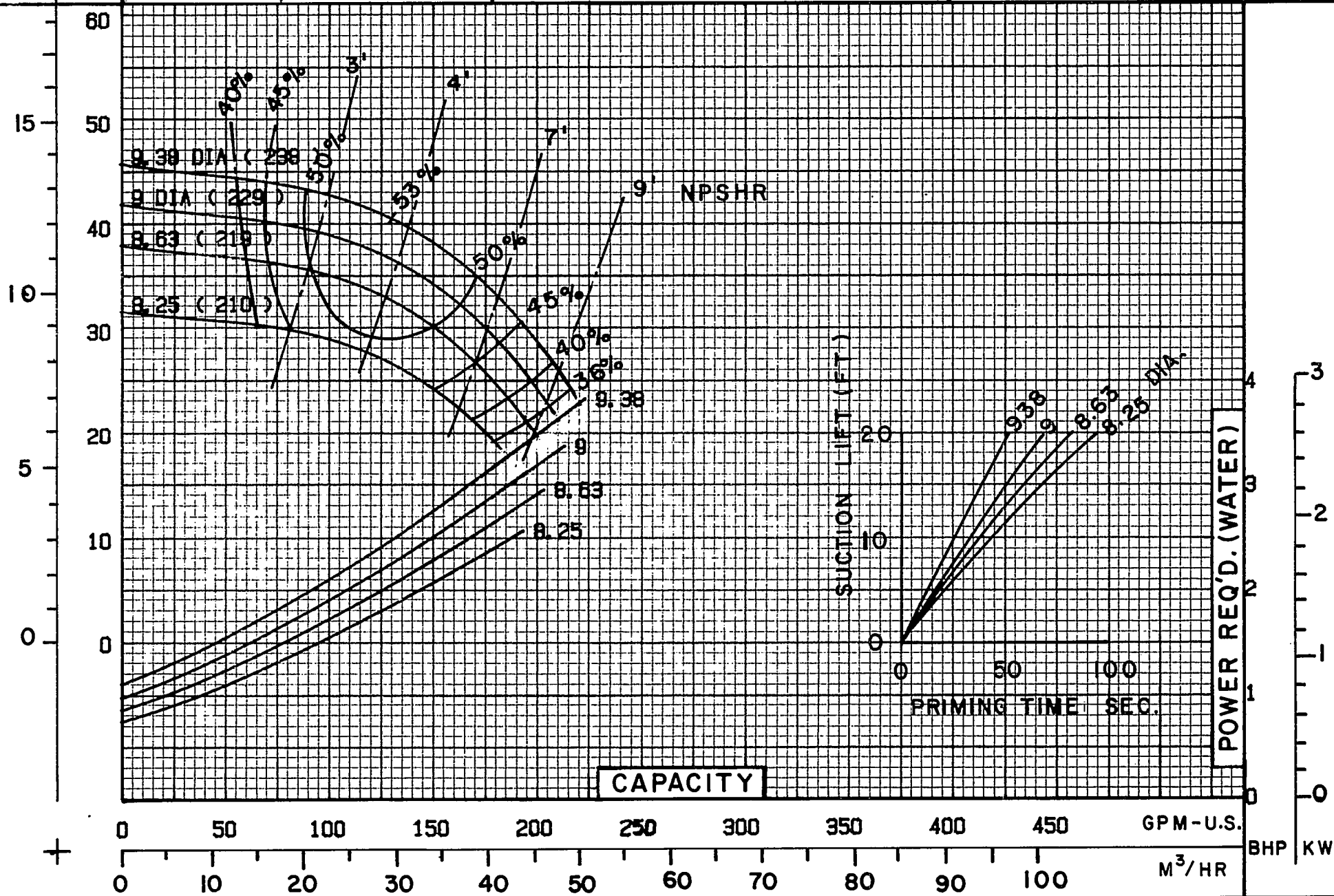

CURVE NO. 20XW-12

T D H

M FT

LaBour
PROCESS PUMPS
ELKHART, IN. 46515

MODEL 20XW TYPE LPL
SIZE 3X3-9.38 in 76X76-238 mm
SPEED 1750 rpm max.sphere

IMPELLER NO. 20XW8SD-BP
EYE AREA in² mm²
CURVE NO. 20XW17

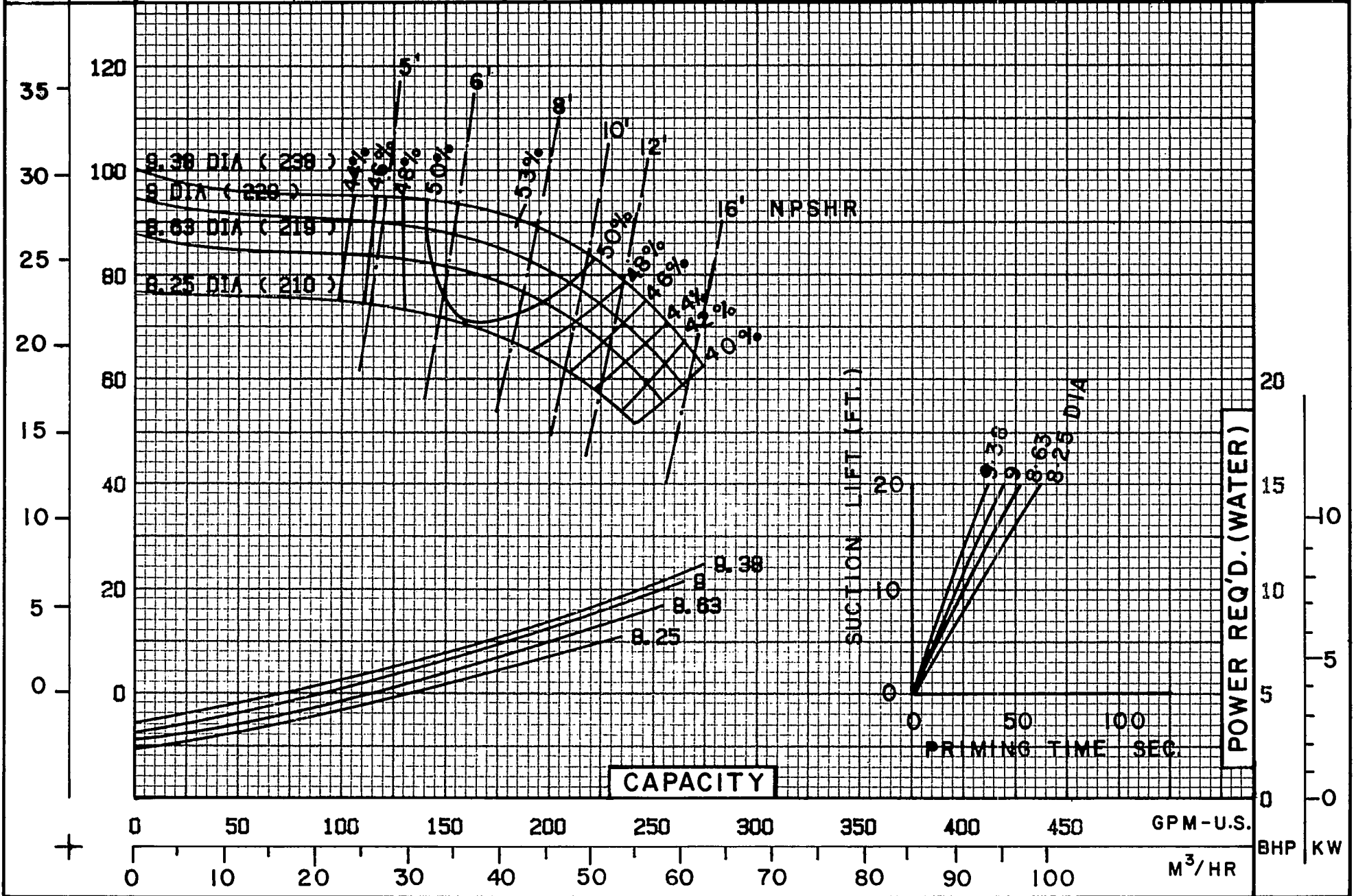

CURVE NO. 20XW-17

T D H

LaBour
PROCESS PUMPS
ELKHART, IN. 46515



MODEL 23XW TYPE LPL
SIZE 3X3-10.0 in 76X76-254 mm
SPEED 1150 rpm _____ max. sphere

IMPELLER NO. 23XW8SD-BP
EYE AREA _____ in² _____ mm²
CURVE NO. 23XW11

M FT

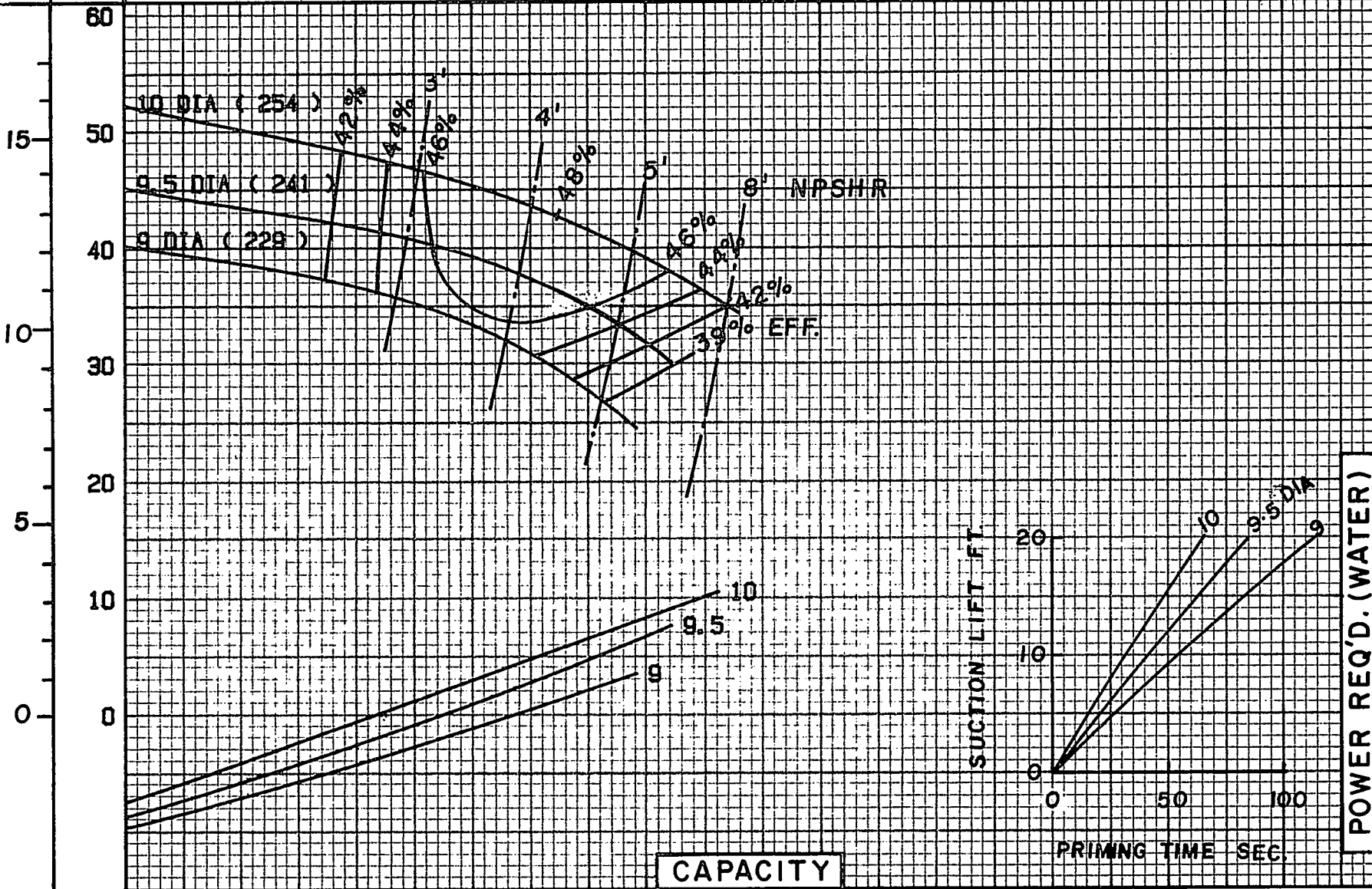

0 50 100 150 200 250 300 350 400 450 GPM-U.S.
 0 10 20 30 40 50 60 70 80 90 M³/HR

POWER REQ'D. (WATER)
 8
 6
 4
 2
 0
 BHP KW

T D H		LaBour PROCESS PUMPS ELKHART, IN. 46515		MODEL <u>23XW</u>	TYPE <u>LPL</u>	IMPELLER NO. <u>23XW8SD-BP</u>
M	FT			SIZE <u>3X3-10.0</u> in <u>76X76-254</u> mm	EYE AREA _____ in ² _____ mm ²	SPEED <u>1750</u> rpm _____ max. sphere

