



**Peerless Pump Company**  
Indianapolis, Indiana 46206-7026

# TECHNICAL INFORMATION

# *Bulletin*

NUMBER 104

## WHAT IS “NPSH”?

Reprinted From

***PETROLEUM REFINER***

**By DAN R. RANKIN**

*Chief Engineer*  
**PEERLESS PUMP COMPANY**

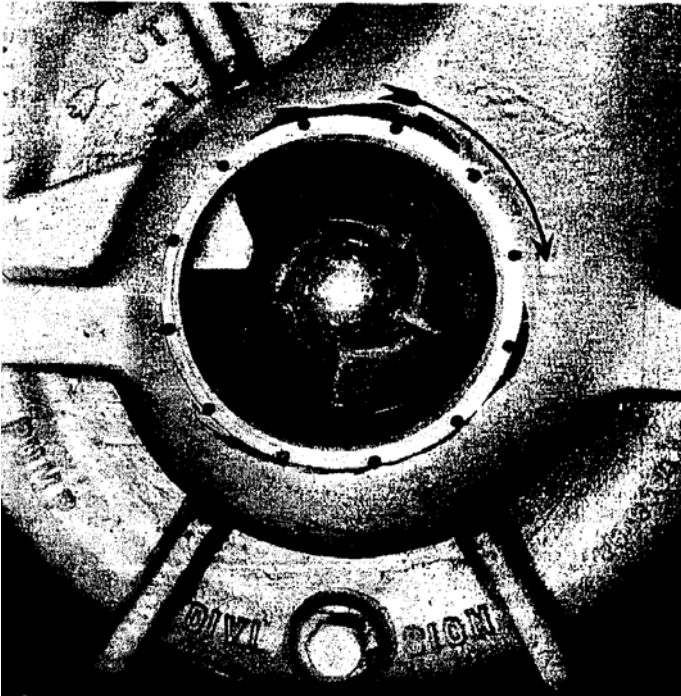

Figure 1

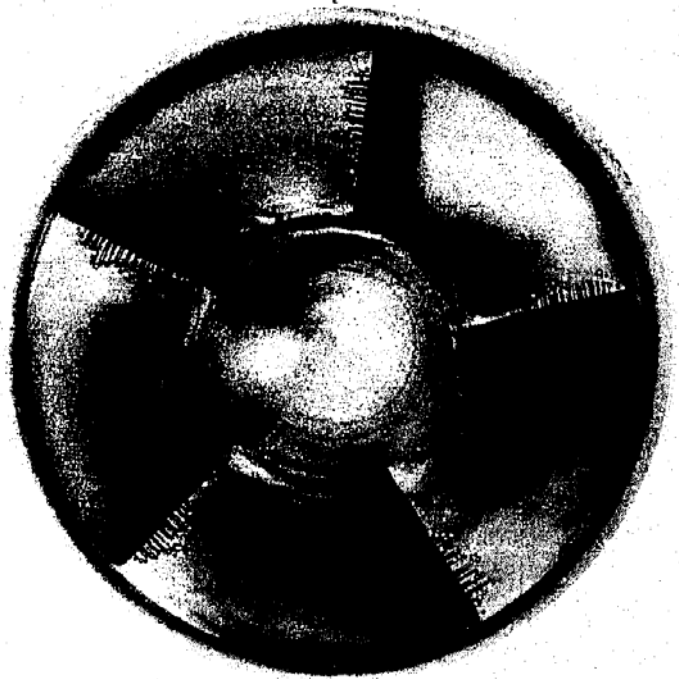

Figure 2.

## What Is “NPSH”?

**This term is widely used by engineers but the physical significance is understood by only a few of them. Here is a description of “NPSH”**

**Dan R. Rankin**

Peerless Pump Company

AT ANY GIVEN temperature all liquids have a definite pressure at which they boil. Every day we witness the fact that a liquid boils at atmospheric pressure when it reaches a sufficiently high temperature. It is important also to remember that a liquid will boil at any temperature if the pressure is reduced sufficiently. It is the problem of the process and pump application engineers to make certain that there is a sufficient pressure on the fluid being fed to the pump so that the liquid does not boil in the suction system of the pump.

The term “suction lift” is very misleading. No reciprocating gear, turbine vane or centrifugal pump can lift any liquid. It is imperative that the liquid be forced into the pump for it to operate properly. The weight of air in the earth's atmosphere is very frequently used to force liquid into the pump suction and creates the illusion that a pump can lift a liquid. In a closed process system where atmospheric or other pressure in excess of the liquid vapor pressure is not available the liquid level must always be maintained above the pump centerline.

The total energy of a liquid is the sum of potential energy (pressure and elevation) and dynamic energy (velocity head). To maintain a constant total energy any increase in the velocity of a liquid reduces the pressure a corresponding amount. In order for a pump to operate, the pressure pushing the liquid into the pump must overcome the static elevation, the friction and turbulence losses in the suction line, accelerate the fluid, and maintain sufficient pressure to keep the fluid in the suction line from boiling.

We are all familiar with the realistic comment made in many cases of crisis that, “Things must get worse before they will get better.” This is equally true of the suction conditions of a centrifugal pump. After fluid has finally been forced through the suction system to the suction flange of a pump a pressure drop occurs within the pump before the impeller can increase the pressure.

### **Why a Pump Requires a Positive Suction Head**

A pressure drop occurs between the pump suction flange and the minimum pressure point within the pump impeller, Figure 5, because of:

- 1) An increase in the velocity between the suction flange and entrance of the impeller vanes.
- 2) Friction and turbulence losses between the suction flange and entrance to the impeller vanes.

It is impossible to design a centrifugal pump in which there is no pressure drop between the suction flange and entrance to the impeller vanes. All pump systems must have a positive suction pressure sufficiently high to overcome this pressure drop within the pump and to keep the fluid from boiling at the pumping temperature.

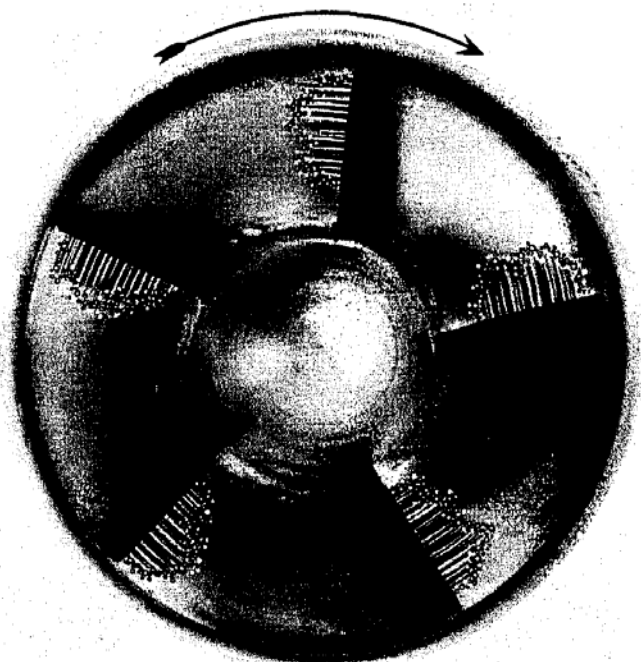

Figure 3

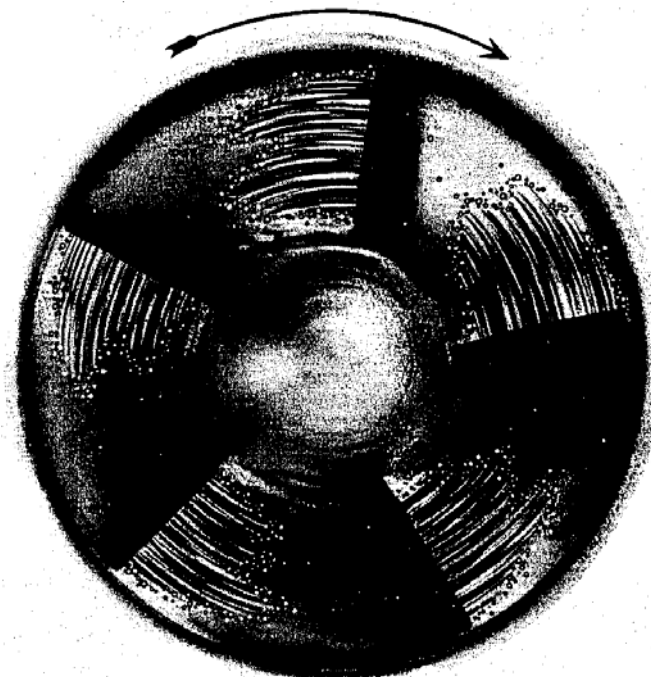

Figure 4.

#### Here's the Explanation of Cavitation Pictures

On process pumps which are designed with top suction manifolds it is possible to install plastic plates at the suction of the pump and by means of stroboscopic lights which flash on and off at the same rate as the rotation of the pump, visualize the flow of fluid around the entrance of the impeller vanes. Figure 1 shows a picture of such a pump with the plastic and plate removed so that the impeller can be seen through the suction portion of the pump case.

Initial stages of cavitation are indicated on Figure 2. It is noted that vapor is beginning to form on the entrance edges of the vanes. Little noise or reduction in pump performance is noted in this stage of cavitation. Impeller vanes may show some pitting after extended operation under these conditions especially if there is any tendency toward corrosion present.

Figure 3 shown the increased formation of vapor which extends over a larger portion of the entrance of the impeller vanes as a result of increasing the suction lift on the pump which decreases the pressure at this area. Normally, some noise would be evident in the pump and a reduction in efficiency and head developed by the pump would become apparent at this stage.

Figure 4 indicates severe cavitation at the impeller vanes as the pressure in the pump is further decreased by further increasing the suction lift. Although the pump will still operate under these conditions, it will be noisy, have a reduced head and efficiency. Vibration would undoubtedly be noticeable and severe pitting would occur on the impellers if operated for an extended period of time under these conditions.

#### Pumping Water at Sea Level

Figure 6 is a schematic chart showing a general condition of pump operation where the energy at the surface of the liquid source is appreciable greater than the vapor pressure of the liquid being handled. A specific example of this condition is pumping water at room temperature where the liquid source is under atmospheric pressure at sea level. The energy indicator to the left shows the total energy at the surface of a water source at sea level due to atmospheric pressure is approximately 34 feet. Of this 34 feet, approximately one foot must be maintained at all times to keep the water from boiling.

This leaves essentially 33 feet of energy at the surface of any normal water source at sea level to force the liquid into the pump.

A pump is shown to the right of the figure with its center line above the liquid level. The total useful energy between the center line of the pump and the height to which the atmospheric pressure holds the water is indicated by the energy indicating tube attached to the suction of the pump. Note the useful pressure which is not available to push the liquid into the pump because of the position of the pump above the liquid level. The pressure at the suction flange of the pump is further reduced by friction and turbulence losses in the suction line and by the energy which must go into accelerating the fluid.

If an absolute pressure gauge were attached to the suction of the pump exactly as indicated in Figure 6 the liquid would stand at the height indicated, designating the useful pressure at this point. As long as the useful pressure above the center line of the pump is sufficient to overcome the pressure drop within the pump, caused by the increase in velocity and the friction between the suction flange and the entrance to the impeller vanes, the pump will continue to operate properly.

#### Pumping Liquids with High Vapor Pressure From Open Tanks

Figure 7 represents a pumping system for a fluid with high vapor pressure such as acetone with the tank opened to the atmosphere at sea level. The total energy at the surface of the liquid is the same as indicated for water in Figure 6. The liquid would rise to the level indicated in an absolute pressure gauge standing in the liquid source. Thus although the total energy at the surface of the acetone would be identical to that of water, the useful pressure to force the fluid into the pump would be appreciably reduced.

Looking at a pump installation identical to that in Figure 6, it is noted that the same friction and velocity pressure losses would occur in the case of acetone assuming it has essentially the same viscosity as water. However, the useful pressure available to force the fluid into the pump is much

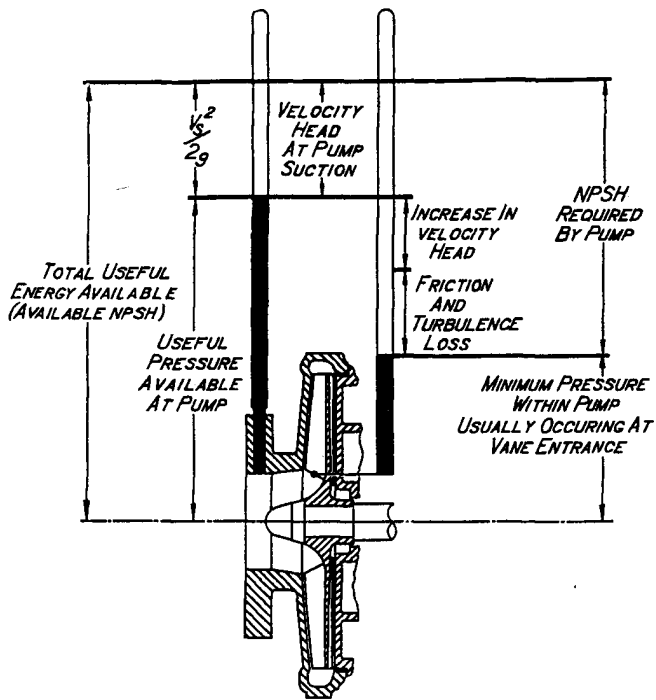

Figure 5. Relation between available NPSH in a system and that required by a pump.

smaller in this example because of the large amount of pressure which is required to keep the fluid in the liquid state. This is the reason why a pump handling a fluid with a higher vapor pressure than that of water at room temperature cannot be located as high above the surface of the liquid to be pumped.

#### What Effect Has Altitude on Pump Suction Conditions?

In these days of flying we are all conscious of the fact that the weight of the air in the earth's atmosphere becomes less at high altitudes. At 20,000-foot elevation the atmospheric pressure is approximately 15 1/2 feet of water. Assuming that a pump was installed at this altitude, the pressure on a water source at room temperature would be 15 1/2 feet. Since the total energy to force the water into the pump must be available at the liquid source and with the same vapor pressure as with our sea level example in Figure 6, the remaining useful pressure is only 14.6 feet. If we locate the pump at the same distance above the water and try to pump the same amount of water, there will be the same loss of useful pressure due to pump location, friction in the suction line, and acceleration of the fluid. The remaining useful pressure to force the fluid into the pump would be entirely inadequate and the pump would not operate under these conditions until it was lowered closer to the liquid source. See Figure 8.

#### What About Liquids at the Boiling Point?

Under certain conditions it is not possible for the pump location to be above the liquid source. As the vapor pressure increases in relation to the pressure on the surface of the liquid source it is necessary to bring the center line of the pump nearer and nearer the source of the liquid until finally the pump must be installed below that liquid source.

The most common installation in process pump application is where the tank is not open to atmospheric pressure but is completely enclosed in a vessel and is maintained

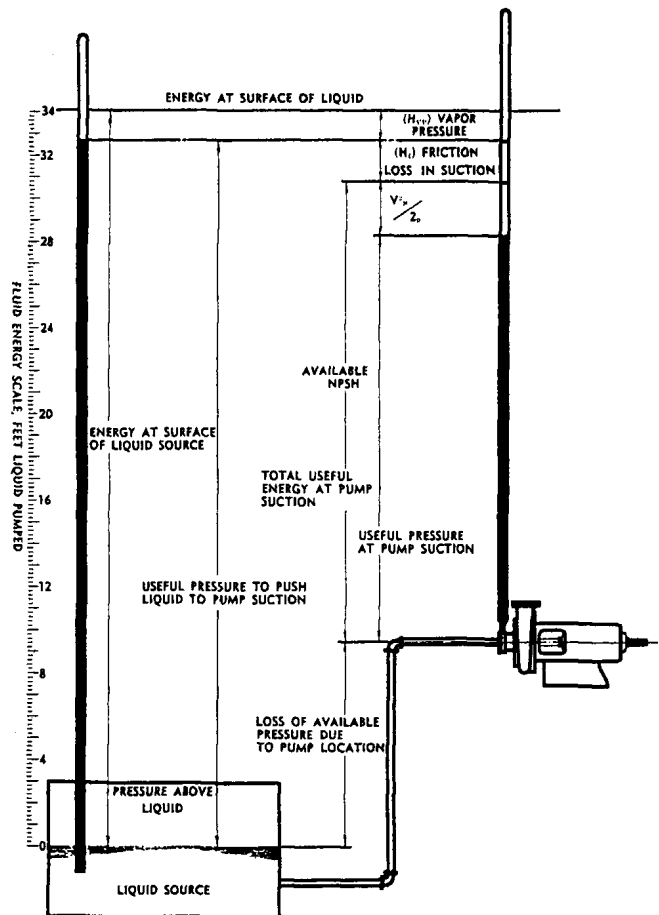

Figure 6. Pumping water at sea level.

at or very near its boiling point. In other words, the vapor pressure above the fluid is the same as that on the surface of the liquid source. In such a case the total energy at the liquid surface simply represents the vapor pressure of the fluid which keeps it in liquid state. There is no additional pressure available to push this liquid into the pump. Therefore, the pump location must be below the surface of this liquid as indicated in Figure 9. In this case the only useful energy available to force the fluid into the pump is that resulting from the difference in location between the center line of the pump shaft and the surface of the boiling liquid. This distance must be sufficient to overcome the friction in the line, accelerate the fluid, and overcome the pressure drop which occurs between the suction flange of the pump and the entrance to the impeller vanes.

#### Now, What Is NPSH?

In the above discussion we have used only absolute pressure and energy values. We now want to identify these values with the term "NPSH".

"The net positive suction head (NPSH) is the total suction head in feet of liquid absolute determined at the suction nozzle and referred to datum, less the vapor pressure of the liquid in feet absolute."

The NPSH required by a pump is equivalent to the drop in pressure between the suction flange of the pump and the entrance to the impeller vanes plus the velocity head at the pump suction. This is indicated graphically in Figure 5 and represents the net positive suction head required by the pump for proper operation. Any system must be so designed

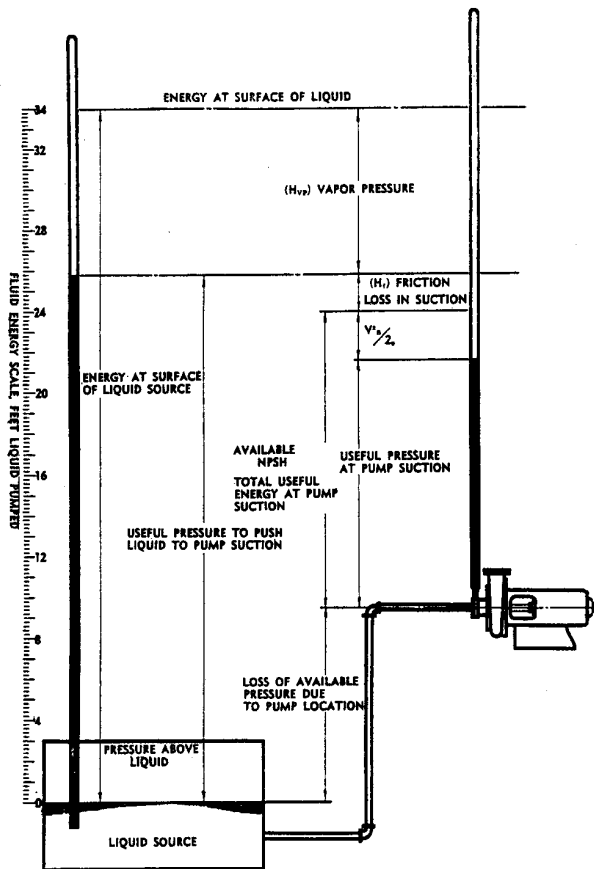

Figure 7. Pumping liquid with high vapor pressure at seal level.

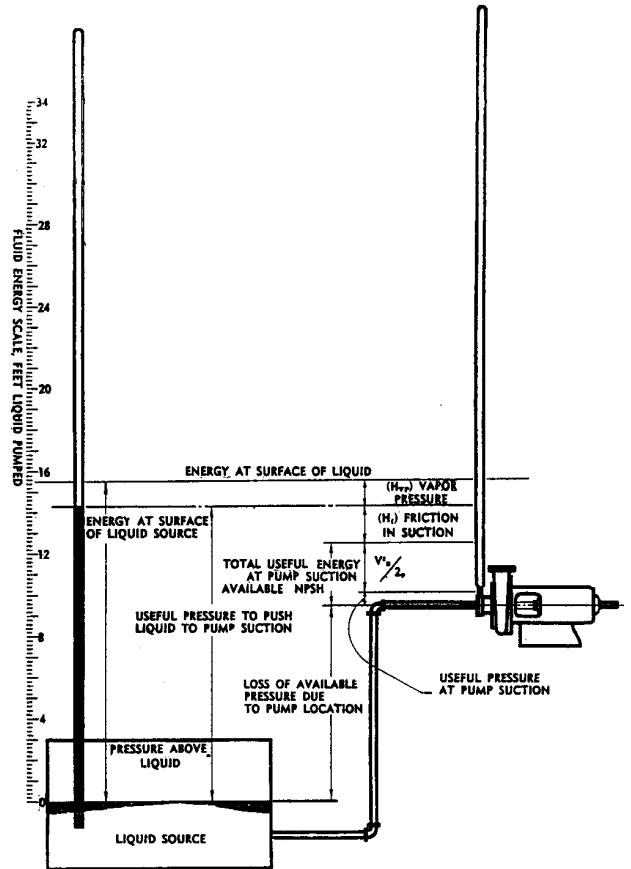

Figure 8. Example of improper pump location when pumping water at 20,000 feet.

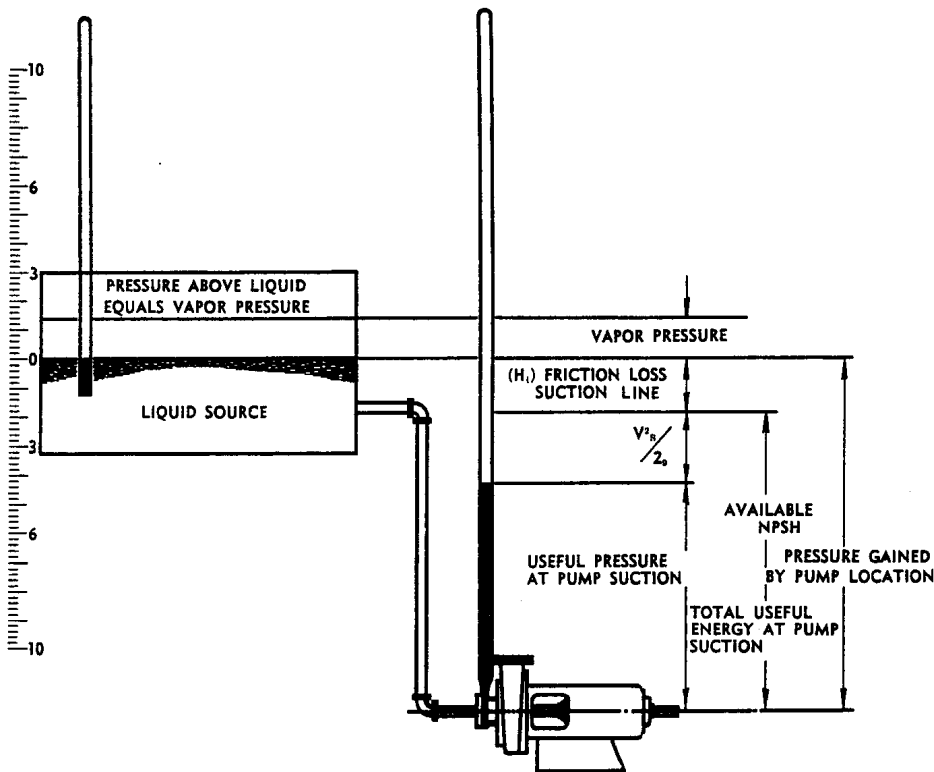

Figure 9. Typical pumping installation when pumping process fluid in a closed system.

must be so designed that the available NPSH of the system is equal to or exceeds the NPSH required by the pump.

The available NPSH of various systems is indicated in Figure 6, 7, 8 and 9 and is identical to the total useful energy at the pump suction.

Since the NPSH required by a pump is a fraction of losses within the pump and the velocity of fluid in the pump, it is dependent upon the speed of operation, the amount of liquid being handled by the pump, and the design of the whole entrance section of the pump including the vane angles and thickness.

Editor's Note: *An understanding of the physical significance of NPSH is important in applying numerical formulae to pumping problems.*

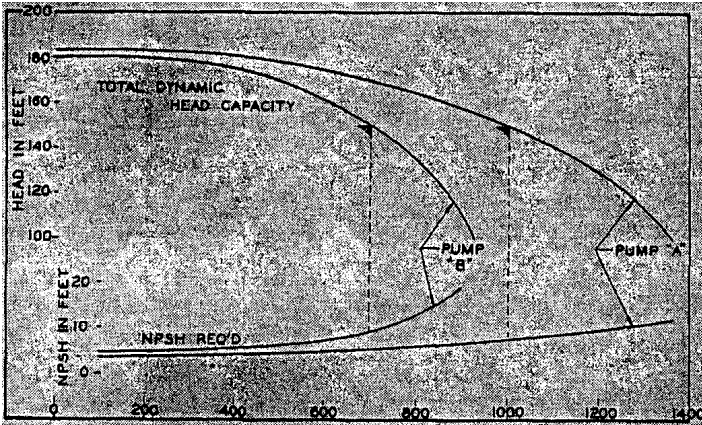

FIGURE 1

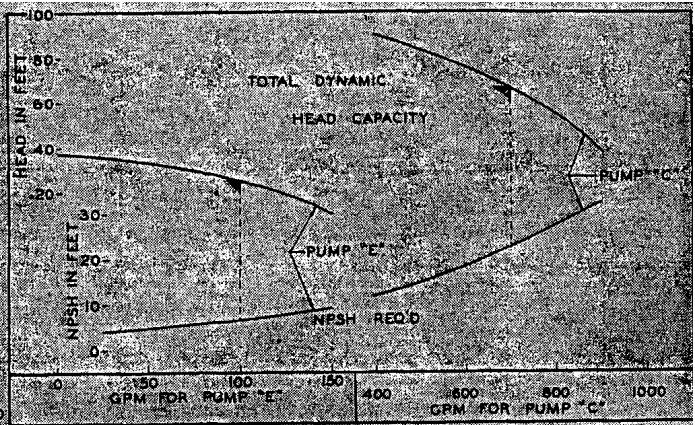

FIGURE 2

## It's Easy to Determine NPSH

Dan R. Rankin Peerless Pump Company,

A MAJOR PROBLEM encountered in many pumping applications, particularly those involving fluids at or near their boiling points, is a lack of net positive suction head (NPSH). Net positive suction head is the absolute pressure, above the vapor pressure of the fluid pumped, available at the pump suction flange, to move and accelerate the fluid entering the impeller.

If the NPSH available in an installation is insufficient, the pump will cavitate and serious operational difficulties may develop. These troubles can include serious reduction in capacity and efficiency, excessive vibration, reduced life of pump parts due to cavitation erosion, and damage to the pump from possible vapor lock and running dry. A series of pictures illustrating cavitation appeared in the May (page 162) issue, 1953, of PETROLEUM REFINER.

A centrifugal pump has a minimum required NPSH to prevent cavitation, which varies with capacity. This characteristic is inherent in the design of a pump and just as much a performance characteristic as its head-capacity relation. In order for a pump to operate cavitation-free, the system NPSH available in an installation must exceed the required NPSH of the pump for operating conditions.

The NPSH required of a pump can be supplied by the pump manufacturer. It is expressed in feet of fluid pumped as is total head developed.

The system NPSH available in a *proposed installation* can be calculated by the formula:

$$H_{sv} = H_p + H_z - H_r - H_{vp}$$

Where:

$$H_{sv} = \text{NPSH expressed in feet of fluid} \quad (1)$$

$H_p$  = absolute pressure on the surface of the liquid where the pump takes suction expressed in feet of fluid.

### Here's the Why

In the May, 1953 issue of PETROLEUM REFINER, this expert, Dan Rankin, published an article "What Is NPSH." We immediately asked him to write one more article and explain in simple terms and with many illustrations a method to calculate the NPSH for various conditions. Here it is. You'll agree it is an excellent treatment of this important subject.

$H_z$  = static elevation of the liquid above the centerline of the pump (on vertical pumps the correction should be made to the entrance eye of the impeller) expressed in feet. If the liquid level is below the pump centerline,  $H_z$  is minus.

$H_r$  = friction and entrance head losses in the suction piping expressed in feet.

$H_{vp}$  = absolute vapor pressure of fluid at the pumping temperature expressed in feet of fluid.

The system NPSH available in an *existing installation* can be measured as follows:

$$H_{sv} = P_a + P_s + 2g - H_{vp} \quad (2)$$

Where:

$P_a$  = atmospheric pressure for the elevation of the installation expressed in feet of fluid.

$P_s$  = gage pressure at the suction flange of the pump corrected to the pump centerline and expressed in feet of fluid.  $P_s$  is minus if it is below atmospheric pressure.

$$\frac{V_s^2}{2g}$$

$2g$  = velocity head at the point of measurement of  $P_s$

$H_{vp}$  = absolute vapor pressure expressed in feet of fluid.

NPSH as explained defines suction conditions of a pump and suction characteristic of a pump. Naturally, NPSH and suction lift are related for suction lift also indicates suction conditions.

Suction lift from known NPSH:

$$H_s = H_p - H_{sv} - H_{vp} \quad (3)$$

Where:

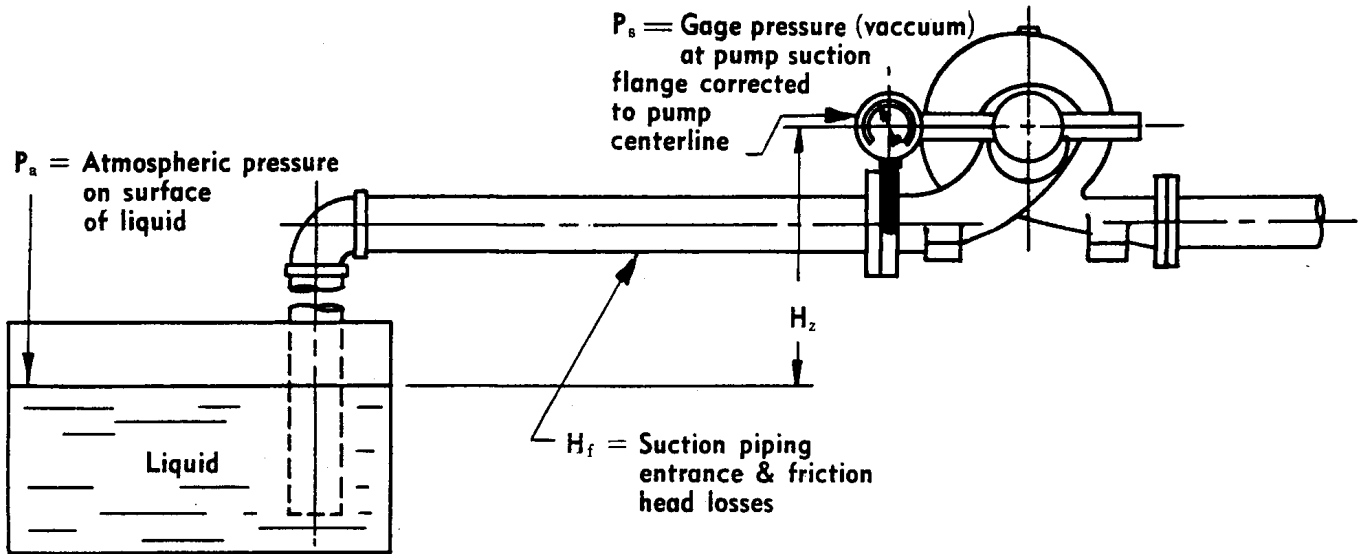

Example 1. Open tank with liquid level below pump centerline.

$H_s$  = total suction lift

The total suction lift is:

$$H_s = H_f - H_z$$

$$H_s = P_a - H_{sv} - H_{vp}$$

from (3)

**Example 1.  
Open Tank with Liquid Level Below  
Pump Centerline**

For this application:

$$H_p = P_a$$

$H_z$  is negative

$P_s$  is negative

Calculated available system NPSH:

$$H_{sv} = P_a + H_z - H_f - H_{vp} \quad \text{from (1)}$$

Measured available system NPSH:

$$H_{sv} = P_a + P_s + \frac{V_s^2}{2g} - H_v \quad \text{from (2)}$$

*Numerical Example:*

Require 1000 gpm at 150 feet TDH pumping 85°F water at 1000 feet elevation above sea level. What is the maximum total suction lift which can be handled using Pump A at 1750 rpm?

$$H_s = P_a - H_{sv} - H_{vp}$$

$P_a = 32.8$  feet (Atmospheric pressure at 1000 feet elevation per Table 1).

$H_{sv} = 7.3$  feet – Maximum NPSH required by Pump A pumping 1000 gpm at 1750 rpm (Figure 1). It should be noted the available NPSH must equal or exceed the minimum required by the pump.

$H_{vp} = 1.38$  feet of water absolute vapor pressure at 85°F.

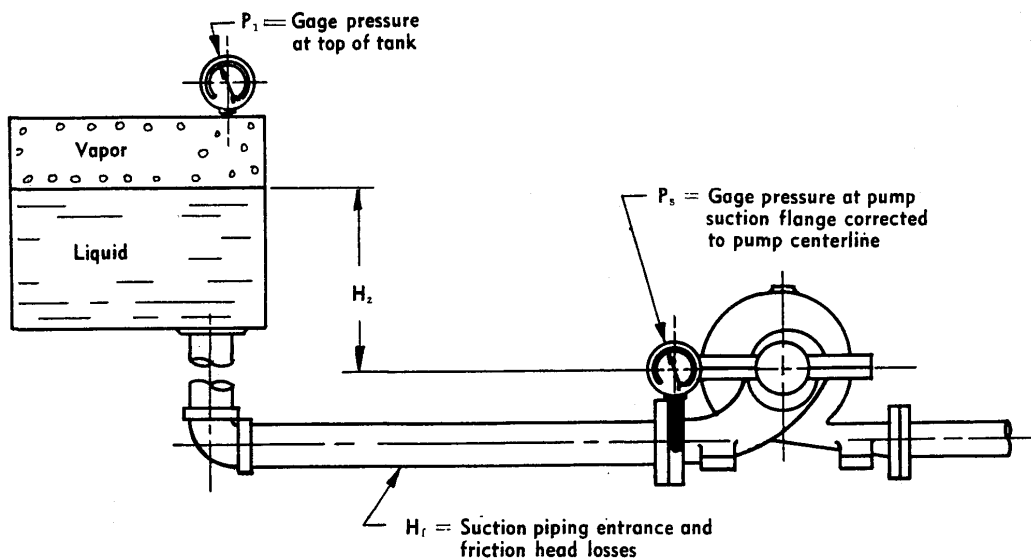

Example 2. Closed tank with liquid level above pump centerline.

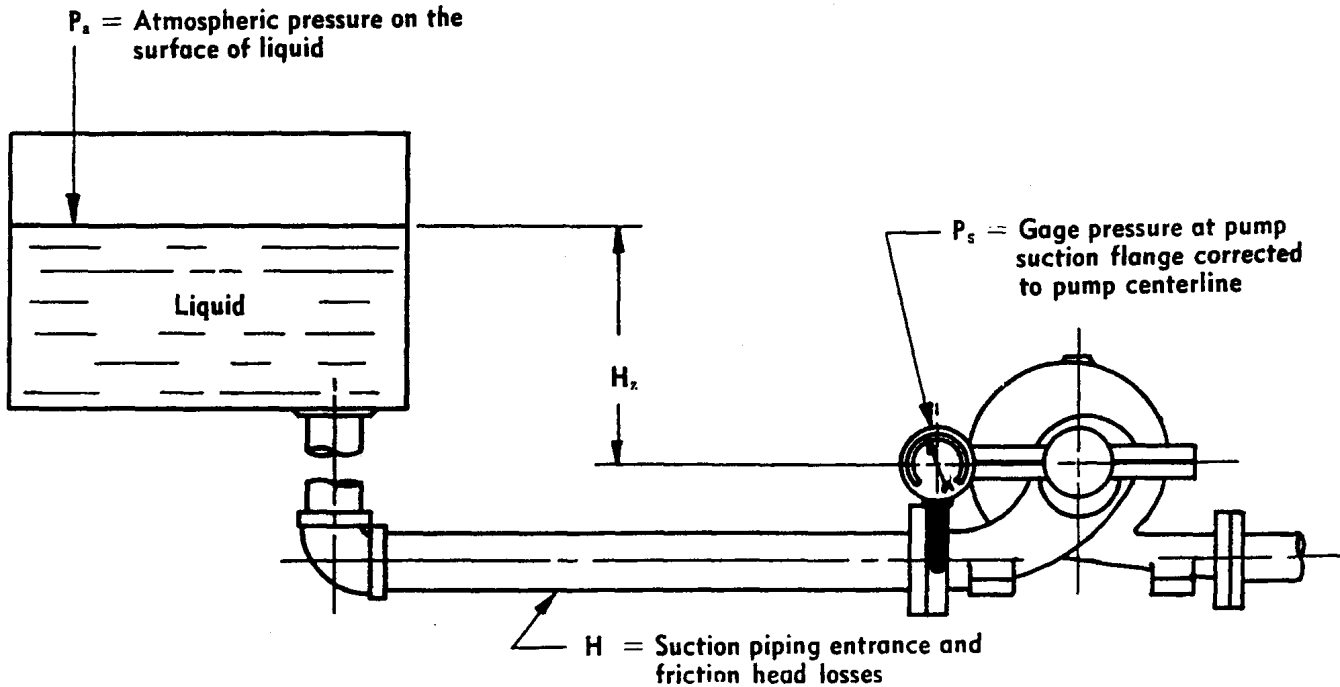

Example 3. Open or vented tank with liquid level above pump centerline.

$$H_s \text{ Max.} = 32.8 - 7.3 - 1.38 = 24.12 \text{ feet.}$$

**Example 2.**

**Closed Tank with Liquid Level Above Pump Centerline**

For this application

$$H_p = \text{Vapor pressure of fluid} = H_{vp}$$

$$H_{sv} = H_{vp} + H_z - H_f - H_{vp}$$

$$H_{sv} = H_z - H_f$$

**Calculated available system NPSH:**

$$H_{sv} = H_z - H_f \quad \text{from (1) where } H_p = H_{vp}$$

It should be noted that an installation with a so called "closed system," as shown above, the liquid source from which the pump takes suction exists at its saturation pressure for the prevailing temperature. Thus, vapor pressure of the liquid equals the pressure on the surface of the liquid and the two terms of the basic NPSH equation nullify each other.

**Measured available system NPSH:**

$$\frac{V_s^2}{2g}$$

$$H_{sv} = P_s + 2g - P_1 \text{ from (2) where } H_{vp} = P_1 + P_a$$

**Numerical Example:**

Require 700 gpm at 150 feet TDH when pumping water (steam condensate) at sea level and at a temperature of 100 F. with 28-inch Hg vacuum existing in the tank using Pump B at 1750 rpm (Figure 1). What is the minimum liquid level above the pump centerline required to prevent cavitation if the loss in the suction piping equals 1 foot?

$$H_z \text{ Min.} = H_{sv} + H_f$$

$$H_{sv} = 9.1 \text{ feet (Minimum required NPSH for Pump B pumping 700 gpm at 1750 rpm per Figure 2).}$$

$$H_f = 1 \text{ foot}$$

$$H_z \text{ Min.} = 9.1 + 1 = 10.1 \text{ feet}$$

**Example 3.**  
**Open or Vented Tank with Liquid Level**

**Above Pump Centerline**

For this application:

$$H_p = P_a$$

$H_z$  is Positive

Calculated available system NPSH:

$$H_{sv} = P_a + H_z - H_f - H_{vp} \quad \text{from (1)}$$

Measured available system NPSH:

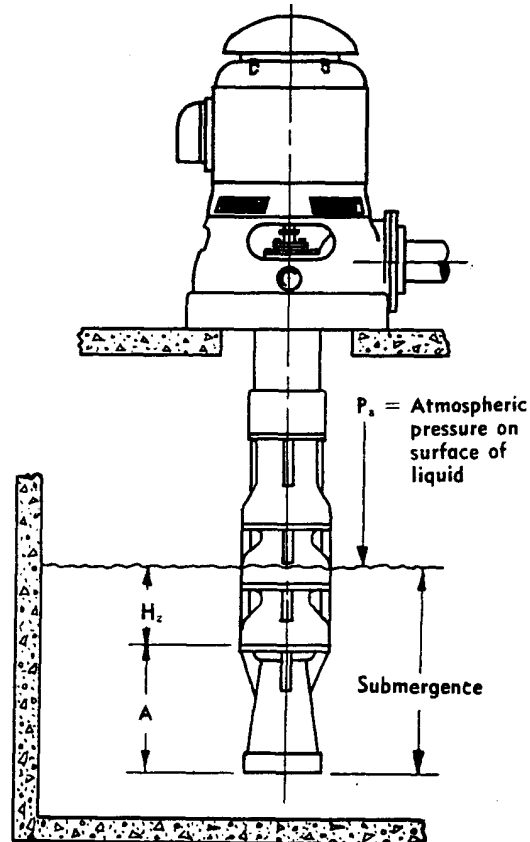

Example 4. Vertical submerged pump in open pit.



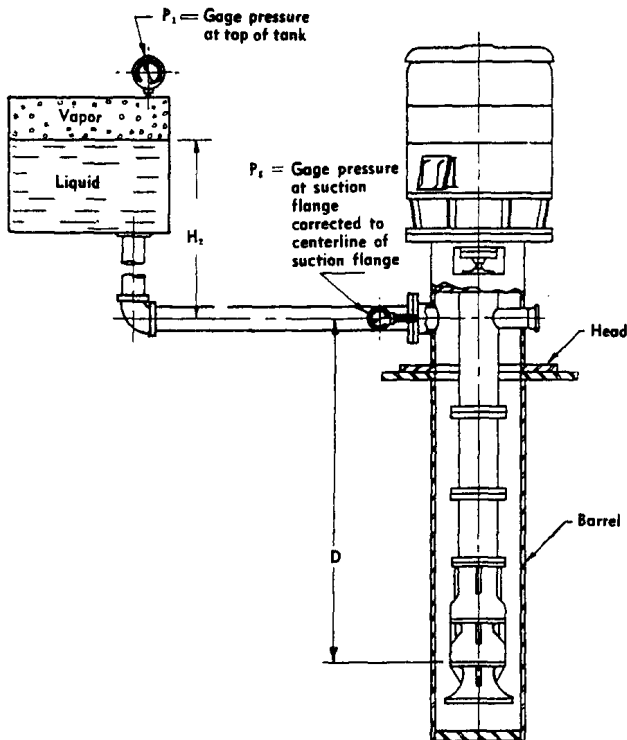

Example 5. Enclosed vertical pump with closed tank above pump.

$$H_{sv} = P_a + P_s + 2g - H_{vp} \quad \text{from (2)}$$

Numerical Example:

Require 1000 gpm at 150 feet TDH handling at sea level gasoline of .73 sp. gr. and 11.5 psia vapor pressure at the pumping temperature. With a minimum liquid level of 2 feet above the pump centerline and suction piping level losses equal to 3 feet, is the NPSH available satisfactory for using Pump A at 1750 rpm?

$$H_{sv} = P_a + H_z - H_f - H_{vp}$$

$P_a = 34$  feet of water (Atmospheric pressure at sea level per Table 1).

Converted to feet of gasoline:

$$P_a = \frac{34}{.73} = 46.5 \text{ feet}$$

$$H_z = 2$$

$$H_f = 3$$

$$H_{vp} = 11.5 \text{ psi}$$

Converted to feet of gasoline

$$H_{vp} = \frac{11.5 \times 2.31}{.73} = 36.4 \text{ feet}$$

$$H_{sv} = 46.5 + 2 - 3 - 36.4 = 9.1 \text{ feet}$$

The required NPSH of Pump A at 1750 rpm (Figure 1)

TABLE 1  
Altitude vs. Atmospheric Pressure

Altitude Above Sea Level	Atm. Pressure in Feet of Water at 75 F.	Altitude Above Sea Level	Atm. Pressure in Feet of Water at 75 F.
0	34.0	5000	28.3
500	33.4	5500	27.8
1000	32.8	6000	27.3
1500	32.2	6500	26.7
2000	31.6	7000	26.2
2500	31.0	7500	25.7
3000	30.5	8000	25.2
3500	29.9	8500	24.8
4000	29.4	9000	24.3
4500	28.8	9500	23.8
		10000	23.4

is 7.3 feet. With the available system NPSH greater than that required by the pump, the pump will perform satisfactorily.

#### Example 4.

#### Vertical Submerged Pump in Open Pit

For this application:

$$H_p = P_a$$

$H_f = 0$  since there is no suction piping.

Available system NPSH:

$$H_{sv} = P_a + H_z - H_{vp} \quad (1)$$

The submergence, a term more frequently used in vertical applications, for installation shown is:

$$\text{Submergence} = H_z + A$$

Numerical Example:

A pump required for 700 gpm at 66 feet TDH pumping water at a temperature of 150 F. at an elevation of 5000 feet above sea level. Using Pump C vertical turbine pump (Figure 2) two stages is the minimum submergence required to prevent cavitation?

$$H_z = H_{sv} - P_a + H_{vp}$$

$P_a = 28.3$  feet (Atmospheric pressure at 5000 feet elevation per Table 1).

Converted to feet of water at 150 F.:

$$\frac{28.3}{.98}$$

$P_a = .98 = 28.9$  (Specific gravity = .98 at 150 F.)

$H_{sv} = 22.5$  feet (Minimum NPSH required by Pump C at 1760 rpm, 700 gpm per Figure 2)

$H_{vp} = 8.8$  feet of water (Vapor pressure for 150 F. water)

$$H_z = 22.5 - 28.9 + 8.8 = 2.4 \text{ feet}$$

$$\text{Submergence} = H_z + A$$

$A = 12$  inches. For suction manifold for Pump C from manufacturers data.

$$\text{Submergence: } 2.4 + 10 = 3.4 \text{ feet.}$$

#### Example 5.

#### Enclosed Vertical Pump with Closed Tank Above Pump

Calculated available system NPSH:

$$H_{sv} = H_z - H_f \quad \text{from (1) where } H_p = H_{vp}$$

Measured available system NPSH:

$$H_{sv} = P_s + 2g - P_1 \quad \text{from (2) where } H_{vp} = P_1 + P_a$$

NOTE: Pump manufacturer's NPSH curves must be corrected to pump suction flange by subtracting "D" from required NPSH because of impeller location.

Numerical Example:

Require propane transfer pump 100 gpm at 25 feet TDH. Minimum liquid height,  $H_z = 3$  feet and friction in line to pump suction,  $H_f = 2$ . Select pump and determine barrel length "D."

Choose pump E at 1760 rpm, Figure 2, requiring 6.1 NPSH at impeller eye.

Calculated available NPSH at pump suction flange:

$$H_{sv} = H_z - H_f$$

$$H_{sv} = 3 - 2 = +1 = \text{Available NPSH}$$

Minimum required pump NPSH at suction flange = 6.1 - D.

Equate available NPSH to required pump NPSH and determine minimum "D."

$$1 = 6.1 - D$$

$$D = 5.1 \text{ Minimum. Make 7 feet to provide safety factor.}$$



Peerless Pump Company  
2005 Dr. Martin Luther King St.  
Indianapolis, IN 46207-7026  
317-925-9661  
[www.peerlesspump.com](http://www.peerlesspump.com)